

The Drawing and its contents are to be kept secret from third parties, particularly competitors. The drawing and documents which go with it are not to be duplicated either in local or extract, or used in other documentation without express approval (815 and 38 UrHG - §1 and 18 UWG). A reservation of rights in accordance with §12 PatG is declared for the event that a patent is granted.

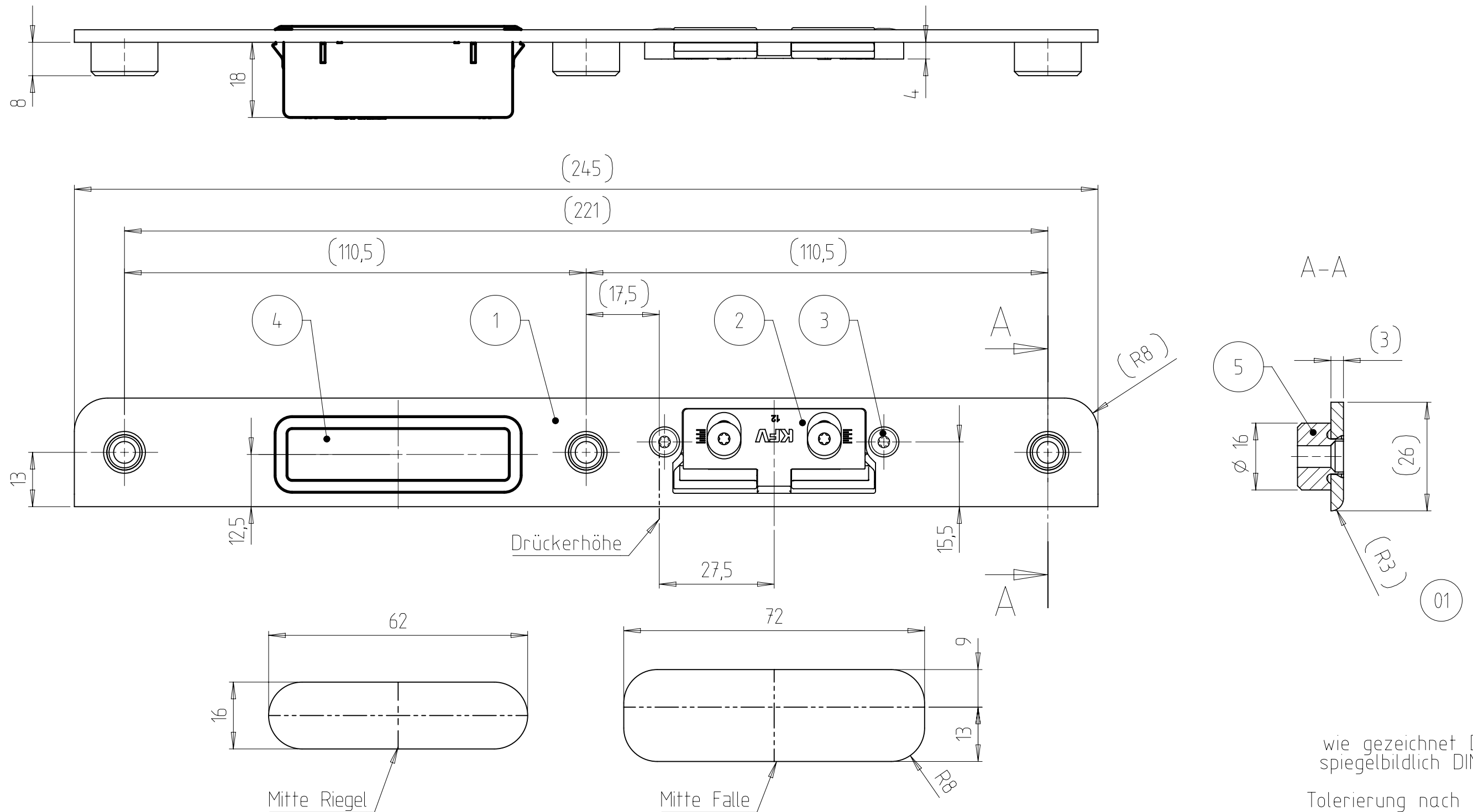

wie gezeichnet DIN links  
spiegelbildlich DIN rechts

Tolerierung nach ISO 8015

Pos. 4 in Pos. 1 geklipst  
Pos. 1 und 2 mit Pos. 3 verschraubt  
Pos. 5 mit Pos. 1 schlagvernietet

Frästiefe = angegebene Tiefe + min. 1mm

Fräser  $\varnothing$  16mm  
Anlauftring  $\varnothing$  27mm

Pos	Benennung	Stck	PDM-Nr.	Teil	Bemerk
5	Distanzstueck	3	9.745.00039	000	
4	Hinterfuetterung	1	9.806.00080	000	
3	Torx - Schraube M4x6	2	9.741.14817	000	
2	AT-Stueck kplt.	1	7.803.16209	000	
1	Flach- Schliessblech	1	9.841.22776	000	

Qty. 1	Type of Modification	Baugruppe aktualisiert	ANT EK1-2244801	Drawn Frerichs	Approved M. M.-Bachem	Date 23.01.2023
Volume /mm <sup>3</sup> 24688	Weight/g 171,200	Material-No.	Item-No. 8050-434E8H	Tool-No.		
		Tolerance ISO 2768 mK	Part-Description Flach- Schliessblech			
Scale 1 : 1		Additional Notice				
Drawn M. Müller-Bachem	Date 17.10.2017	<b>KFV</b>	Document No. 7.841.22777	Doc. Part No. 000	Revision 01	Status 20
Appr. P. Thode	Date 18.10.2017		Replacement for :	Test procedure		Size A3
			Replaced by :			