

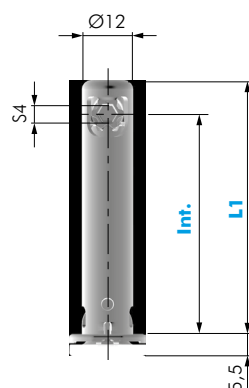

CARATTERISTICHE:

- PIEDINO LIVELLATORI PER ARMADI, INTERPARETI E MOBILI COMPONIBILI
- REGOLABILE DALL'INTERNO DEL MOBILE CON CHIAVE ESAGONALE S4
- REGOLAZIONE ORTOGONALE ALL'ASSE DEL PIEDINO
- CARICO SOLLEVABILE 150 KG
- BREVETTATO

PIEDINI E
RUOTE

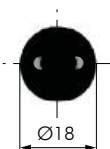
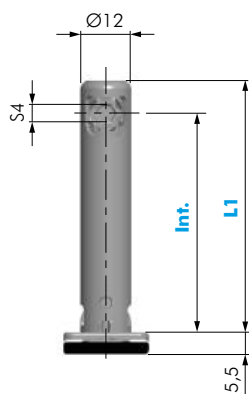
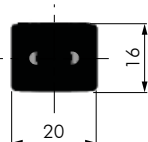
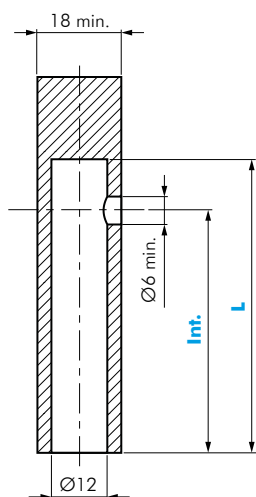

SPESSORE FIANCO	CODICE	DESCRIZIONE	INT	L min.	L1	REG.	MATERIALE	QUANTITÀ
≥ 18	30303010	REKORD TECH Ø12 BASE RETTANGOLARE	25	34	33	10	ZAMA PLAST FE	500
	30303020		32	41	40			
	30303030		44	53	52	25		250
	30303040		52	61	60			
	30303050		70	79	78			
	30303060		100	109	108			
	30303070		120	129	128			
							100	



SPESSORE FIANCO	CODICE	DESCRIZIONE	INT	L min.	L1	REG.	MATERIALE	QUANTITÀ
≥ 18	30303110	REKORD TECH Ø12 BASE TONDA	25	34	33	10	ZAMA PLAST FE	500
	30303120		32	41	40			
	30303130		44	53	52	25		250
	30303140		52	61	60			
	30303150		70	79	78			
	30303160		100	109	108			
	30303170		120	129	128			
							100	



CARATTERISTICHE:

- PIEDINO LIVELLATORI PER ARMADI, INTERPARETI E MOBILI COMPONIBILI
- REGOLABILE DALL'INTERNO DEL MOBILE CON CHIAVE ESAGONALE S4
- REGOLAZIONE ORTOGONALE ALL'ASSE DEL PIEDINO
- CARICO SOLLEVABILE 150 KG
- BREVETTATO

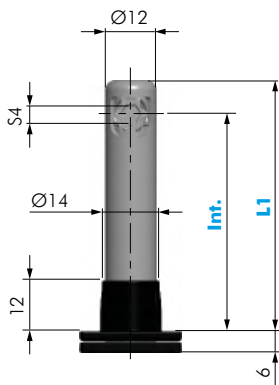
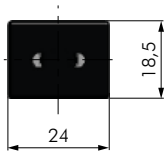
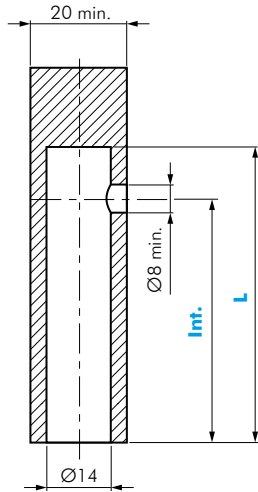

SPESSORE FIANCO	CODICE	DESCRIZIONE	INT	L min.	L1	REG.	MATERIALE	QUANTITÀ
≥ 20	30304010	REKORD TECH Ø14	25	34	33	10	ZAMA PLAST FE	400
	30304020		32	41	40			
	30304030		44	53	52	25		250
	30304040		52	61	60			
	30304050		70	79	78			
	30304060		100	108	108			
	30304070		120	128	128			

INSTALLAZIONE REKORD TECH Ø12 E REKORD TECH Ø14

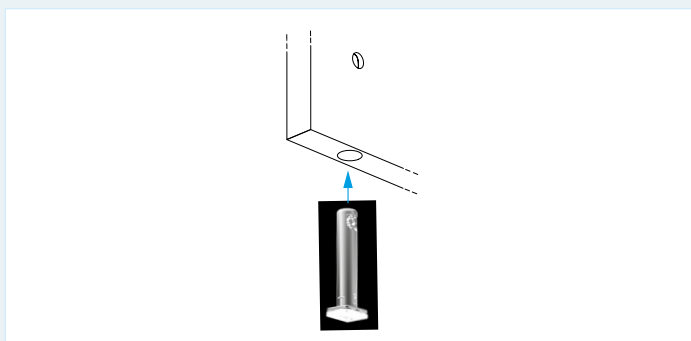

1. INSERIMENTO REKORD TECH

INSERIRE REKORD TECH NEL FORO PRESENTE NELLA PARTE INFERIORE DEL FIANCO.

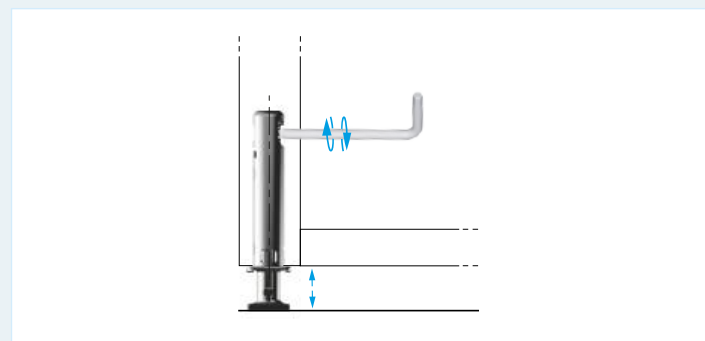

2. REGOLAZIONE REKORD TECH

REGOLARE REKORD TECH CON UNA CHIAVE ESAGONALE S4.