



## DICHIARAZIONE DI PRESTAZIONE

### DoP 0231

per il Sistema a Iniezione fischer FIS-V-Plus (ancorante chimico per l'utilizzo nel calcestruzzo)

IT

1. <u>Codice di identificazione unico del prodotto-tipo:</u>	<b>DoP 0231</b>		
2. <u>Usi previsti:</u>	<b>Fissaggio post-installato in calcestruzzo fessurato o non fessurato.</b>		
3. <u>Fabbricante:</u>	<b>Vedi appendice, in particolare gli allegati da B1- B12 fischerwerke GmbH &amp; Co. KG, Otto-Hahn-Straße 15, 79211 Denzlingen, Germany</b>		
4. <u>Mandatario:</u>	-		
5. <u>Sistemi di VVCP:</u>	1		
6. <u>Documento per la valutazione europea:</u> Valutazione tecnica europea: Organismo di valutazione tecnica: Organismi notificati:	<b>EAD 330499-01-0601 Edition 04/2020 ETA-20/0603; 2020-11-13 DIBt- Deutsches Institut für Bautechnik 2873 TU Darmstadt</b>		
7. <u>Prestazioni dichiarate:</u> <b>Resistenza meccanica e stabilità (BWR 1)</b> Resistenza caratteristica al carico di tensione (carico statico e quasi-statico):	Resistenza alla rottura dell'acciaio:  Resistenza alla rottura del calcestruzzo combinata con sfilamento:  Resistenza alla rottura del cono di calcestruzzo: Distanza dal bordo per evitare lo splitting sotto carico:  Robustezza: Massima coppia di installazione:  Distanza dal bordo e interassi minimi:	Allegati C1-C3  Allegati C4-C9  Allegati C4 Allegato C4  Allegati C4-C9,C14 Allegati B3, B6, B8  Allegati B3-B8	$E_s = 210\,000\text{ MPa}$
Resistenza caratteristica al carico di taglio (carico statico e quasi statico):	Resistenza alla rottura dell'acciaio: Resistenza alla rottura per pry-out: Resistenza alla rottura del bordo di calcestruzzo:	Allegati C1- C3 Allegato C4 Allegato C4	
Resistenza e spostamenti caratteristici per le categorie di prestazione sismica C1 e C2	Resistenza al carico di trazione, spostamenti, categoria C1: Resistenza al carico di trazione, spostamenti, categoria C2: Resistenza al carico di taglio, spostamenti, categoria C1: Resistenza al carico di taglio, spostamenti, categoria C2: Fattore spazio anulare:	Allegati C12-C14 Allegati C12,C13,C15 Allegati C12, C13 Allegati C12,C13,C15 Allegato C12	
Spostamenti con carichi a breve e a lungo termine:	Spostamenti con carichi a breve e a lungo termine:	Allegati C10, C11	
<b>Igiene, salute e ambiente (BWR 3)</b> Contenuto, emissione e/o rilascio di sostanze pericolose	NPD		



8. Documentazione tecnica appropriata e/o  
documentazione tecnica specifica:

La prestazione del prodotto sopra identificato è conforme all'insieme delle prestazioni dichiarate. La presente dichiarazione di prestazione è emessa, in conformità al regolamento (UE) n. 305/2011, sotto la sola responsabilità del fabbricante sopra identificato.

Firmato a nome e per conto del fabbricante da:

Dr. Oliver Geibig, Direttore Generale Unità di Business & Engineering  
Tumlingen, 2020-11-27

Jürgen Grün, Direttore Generale Chimica & Qualità

Questa Dichiarazione di Prestazione (DoP) è stata preparata in varie lingue. In caso di contestazioni sull'interpretazione, prevarrà sempre la versione inglese.

L'Appendice include informazioni volontarie e complementari in lingua inglese che superano i requisiti di legge (lingua specificata in modo neutrale).

## Specific Part

### 1 Technical description of the product

The "fischer Injection system FIS V Plus" is a bonded anchor consisting of a cartridge with injection mortar according to Annex A 4 and a steel element according to Annex A 1 to A 3.

The steel element is placed into a drilled hole filled with injection mortar and is anchored via the bond between metal part, injection mortar and concrete.

The product description is given in Annex A.

### 2 Specification of the intended use in accordance with the applicable European Assessment Document

The performances given in Section 3 are only valid if the anchor is used in compliance with the specifications and conditions given in Annex B.

The verifications and assessment methods on which this European Technical Assessment is based lead to the assumption of a working life of the anchor of at least 50 and/or 100 years. The indications given on the working life cannot be interpreted as a guarantee given by the producer, but are to be regarded only as a means for choosing the right products in relation to the expected economically reasonable working life of the works.

### 3 Performance of the product and references to the methods used for its assessment

#### 3.1 Mechanical resistance and stability (BWR 1)

Essential characteristic	Performance
Characteristic resistance to tension load (static and quasi-static loading)	See Annex C 1, C 2, C 4 to C 9, B 4, B 5
Characteristic resistance to shear load (static and quasi-static loading)	See Annex C 1 to C 3
Displacements under short-term and long-term loading	See Annex C 10 to C 11
Characteristic resistance and displacements for seismic performance categories C1 and C2	See Annex C 12 to C 15

#### 3.2 Hygiene, health and the environment (BWR 3)

Essential characteristic	Performance
Content, emission and/or release of dangerous substances	No performance assessed

4

**Assessment and verification of constancy of performance (AVCP) system applied, with reference to its legal base**

In accordance with the European Assessment Document EAD 330499-01-0601 the applicable European legal act is: [96/582/EC].

The system to be applied is: 1

# Installation conditions part 1

## fischer anchor rod

### Pre-positioned installation

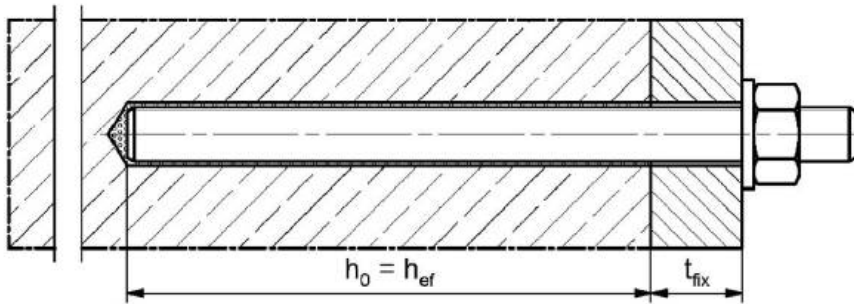

### Push through installation (annular gap filled with mortar)

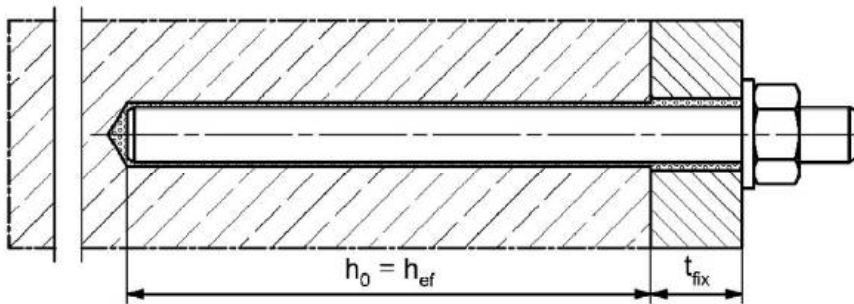

### Pre-positioned or push through installation with subsequently injected fischer filling disc (annular gap filled with mortar)

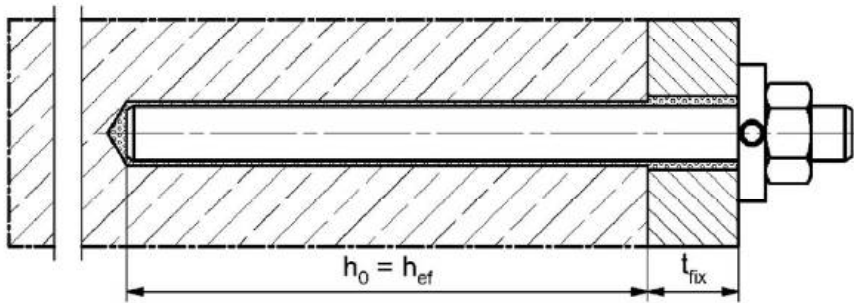

Figures not to scale

$h_0$  = drill hole depth

$h_{ef}$  = effective embedment depth

$t_{fix}$  = thickness of fixture

fischer injection system FIS V Plus

**Product description**  
Installation conditions part 1

**Annex A 1**

Appendix 3 / 35

## Installation conditions part 2

### fischer internal threaded anchor RG MI

#### Pre-positioned installation

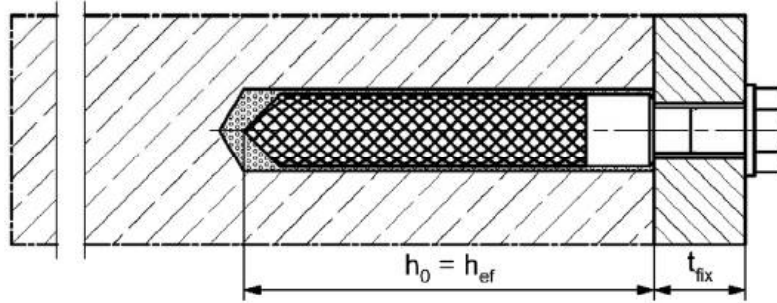

#### Pre-positioned installation with subsequently injected fischer filling disc (annular gap filled with mortar)

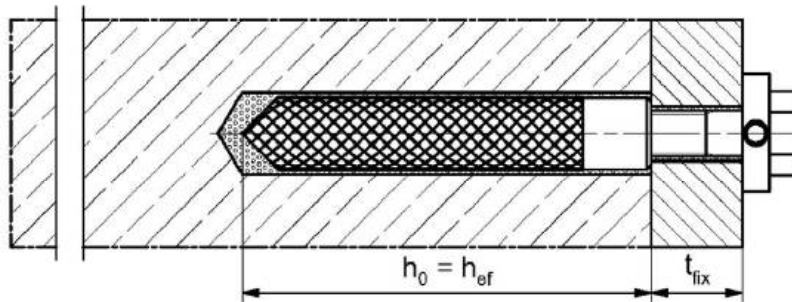

Figures not to scale

$h_0$  = drill hole depth

$h_{ef}$  = effective embedment depth

$t_{fix}$  = thickness of fixture

fischer injection system FIS V Plus

**Product description**  
Installation conditions part 2

**Annex A 2**

Appendix 4 / 35

# Installation conditions part 3

## Reinforcing bar

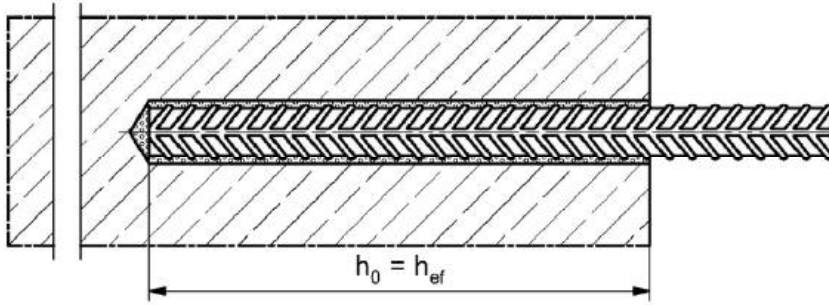

## fischer rebar anchor FRA

### Pre-positioned installation

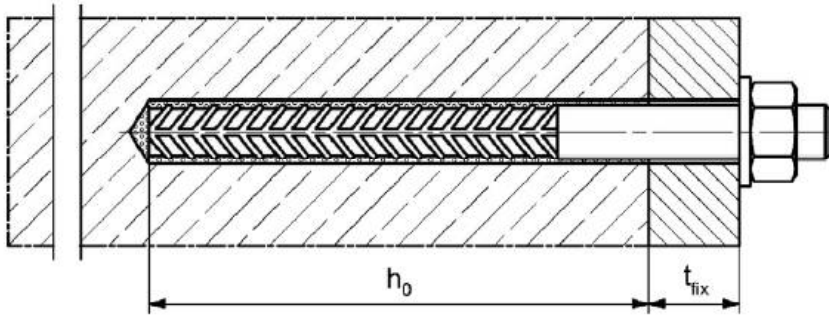

### Push through installation (annular gap filled with mortar)

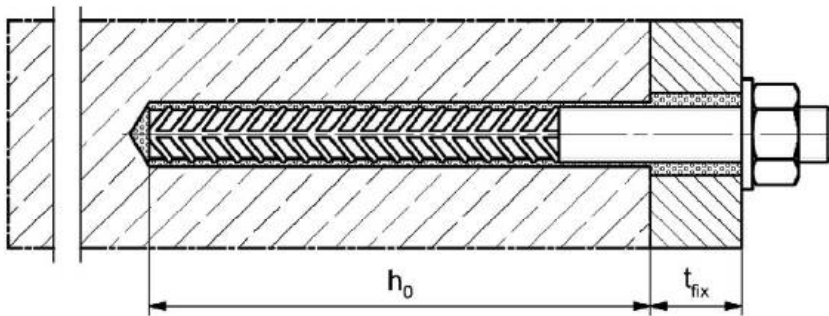

Figures not to scale

$h_0$  = drill hole depth

$h_{ef}$  = effective embedment depth

$t_{fix}$  = thickness of fixture

fischer injection system FIS V Plus

**Product description**  
Installation conditions part 3

**Annex A 3**

Appendix 5 / 35

# Overview system components part 1

**Injection cartridge (shuttle cartridge) with sealing cap; Sizes: 350 ml, 360 ml, 390 ml, 550 ml, 1100 ml, 1500 ml**

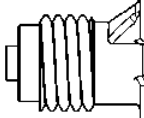
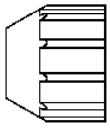

**Imprint:** fischer FIS V Plus or FIS VW Plus High Speed or FIS VS Plus Low Speed, processing notes, shelf-life, piston travel scale (optional), curing times and processing times (depending on temperature), hazard code, size, volume/weight



**Injection cartridge (coaxial cartridge) with sealing cap; Sizes: 100 ml, 150 ml, 300 ml, 380 ml, 400 ml, 410 ml**

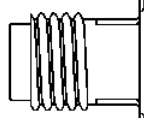
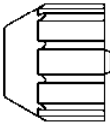

**Imprint:** fischer FIS V Plus or FIS VW Plus High Speed or FIS VS Plus Low Speed, processing notes, shelf-life, piston travel scale (optional), curing times and processing times (depending on temperature), hazard code, size, volume/weight



**Static mixer FIS MR Plus for injection cartridges up to 410 ml**

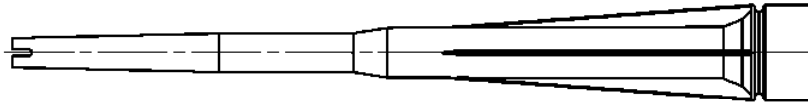

**Static mixer FIS UMR for injection cartridges from 550 ml**

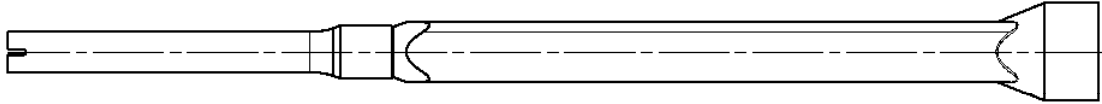

**Injection adapter and extension tube Ø 9 for static mixer FIS MR Plus;  
Injection adapter and extension tube Ø 9 or Ø 15 for static mixer FIS UMR**

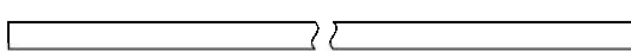

**Cleaning brush BS**



**Blow-out pump**

**AB G:**



**ABP:**



Figures not to scale

fischer injection system FIS V Plus

**Product description**

Overview system components part 1;  
cartridges / static mixer / accessories

**Annex A 4**

Appendix 6 / 35



## Overview system components part 2

### fischer anchor rod

Size: M6, M8, M10, M12, M16, M20, M24, M27, M30

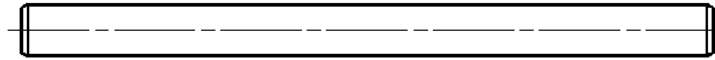

### fischer internal threaded anchor RG MI

Size: M8, M10, M12, M16, M20

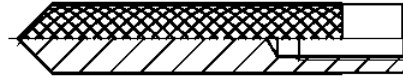

### Screw / threaded rod / washer / hexagon nut

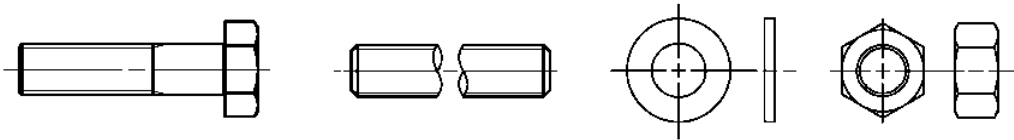

### fischer filling disc with injection adapter

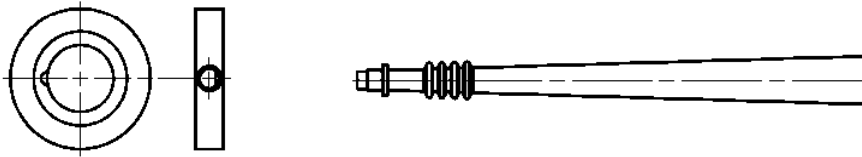

### Reinforcing bar

Nominal diameter:  $\phi 8$ ,  $\phi 10$ ,  $\phi 12$ ,  $\phi 14$ ,  $\phi 16$ ,  $\phi 20$ ,  $\phi 25$ ,  $\phi 28$



### fischer rebar anchor FRA

Size: M12, M16, M20, M24



Figures not to scale

### fischer injection system FIS V Plus

#### Product description

Overview system components part 2;  
metal parts, injection adapter

### Annex A 5

Appendix 7 / 35

**Table A6.1: Materials**

Part	Designation	Material		
1	Injection cartridge	Mortar, hardener, filler		
	Steel grade	Steel	Stainless steel R	High corrosion resistant steel HCR
		zinc plated	acc. to EN 10088-1:2014 Corrosion resistance class CRC III acc. to EN 1993-1-4:2015	acc. to EN 10088-1:2014 Corrosion resistance class CRC V acc. to EN 1993-1-4:2015
2	Anchor rod	Property class 4.8, 5.8 or 8.8; EN ISO 898-1:2013 zinc plated $\geq 5 \mu\text{m}$ , ISO 4042:2018/Zn5/An(A2K) or hot dip galvanised $\geq 40 \mu\text{m}$ EN ISO 10684:2004 $f_{uk} \leq 1000 \text{ N/mm}^2$ $A_5 > 12\%$ fracture elongation	Property class 50, 70 or 80 EN ISO 3506-1:2009 1.4401; 1.4404; 1.4578; 1.4571; 1.4439; 1.4362; 1.4062, 1.4662, 1.4462; EN 10088-1:2014 $f_{uk} \leq 1000 \text{ N/mm}^2$ $A_5 > 12\%$ fracture elongation	Property class 50 or 80 EN ISO 3506-1:2009 or property class 70 with $f_{yk} = 560 \text{ N/mm}^2$ 1.4565; 1.4529; EN 10088-1:2014 $f_{uk} \leq 1000 \text{ N/mm}^2$ $A_5 > 12\%$ fracture elongation
		Fracture elongation $A_5 > 8\%$ , for applications without requirements for seismic performance category C2		
3	Washer ISO 7089:2000	zinc plated $\geq 5 \mu\text{m}$ , ISO 4042:2018/Zn5/An(A2K) or hot dip galvanised $\geq 40 \mu\text{m}$ EN ISO 10684:2004	1.4401; 1.4404; 1.4578; 1.4571; 1.4439; 1.4362; EN 10088-1:2014	1.4565; 1.4529; EN 10088-1:2014
4	Hexagon nut	Property class 4, 5 or 8; EN ISO 898-2:2012 zinc plated $\geq 5 \mu\text{m}$ , ISO 4042:2018/Zn5/An(A2K) or hot dip galvanised $\geq 40 \mu\text{m}$ EN ISO 10684:2004	Property class 50, 70 or 80 EN ISO 3506-1:2009 1.4401; 1.4404; 1.4578; 1.4571; 1.4439; 1.4362; EN 10088-1:2014	Property class 50, 70 or 80 EN ISO 3506-1:2009 1.4565; 1.4529; EN 10088-1:2014
5	fischer internal threaded anchor RG MI	Property class 5.8 ISO 898-1:2013 zinc plated $\geq 5 \mu\text{m}$ , ISO 4042:2018/Zn5/An(A2K)	Property class 70 EN ISO 3506-1:2009 1.4401; 1.4404; 1.4578; 1.4571; 1.4439; 1.4362; EN 10088-1:2014	Property class 70 EN ISO 3506-1:2009 1.4565; 1.4529; EN 10088-1:2014
6	Commercial standard screw or threaded rod for fischer internal threaded anchor RG MI	Property class 5.8 or 8.8; EN ISO 898-1:2013 zinc plated $\geq 5 \mu\text{m}$ , ISO 4042:2018/Zn5/An(A2K) $A_5 > 8\%$ fracture elongation	Property class 70 EN ISO 3506-1:2009 1.4401; 1.4404; 1.4578; 1.4571; 1.4439; 1.4362; EN 10088-1:2014 $A_5 > 8\%$ fracture elongation	Property class 70 EN ISO 3506-1:2009 1.4565; 1.4529; EN 10088-1:2014 $A_5 > 8\%$ fracture elongation
7	fischer filling disc similar to DIN 6319-G	zinc plated $\geq 5 \mu\text{m}$ , ISO 4042:2018/Zn5/An(A2K) or hot dip galvanised $\geq 40 \mu\text{m}$ EN ISO 10684:2004	1.4401; 1.4404; 1.4578; 1.4571; 1.4439; 1.4362; EN 10088-1:2014	1.4565; 1.4529; EN 10088-1:2014
8	Reinforcing bar EN 1992-1-1:2004 and AC:2010, Annex C	Bars and de-coiled rods, class B or C with $f_{yk}$ and $k$ according to NDP or NCL of according to EN 1992-1-1:2004/NA $f_{tk} = f_{tk} = k \cdot f_{yk}$		
9	fischer rebar anchor FRA	Rebar part: Bars and de-coiled rods class B or C with $f_{yk}$ and $k$ according to NDP or NCL of EN 1992-1-1:2004+AC:2010 $f_{tk} = f_{tk} = k \cdot f_{yk}$	Threaded part: Property class 70 or 80 EN ISO 3506-1:2009 1.4401, 1.4404, 1.4571, 1.4578, 1.4439, 1.4362, 1.4062 acc. to EN 10088-1:2014 Corrosion resistance class CRC III acc. to EN 1993-1-4:2015 1.4565; 1.4529 acc. to EN 10088-1:2014 Corrosion resistance class CRC V acc. to EN 1993-1-4:2015	

fischer injection system FIS V Plus





**Product description**  
Materials

**Annex A 6**

Appendix 8 / 35

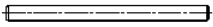
# Specifications of intended use (part 1)

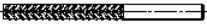
**Table B1.1:** Overview use and performance categories

		FIS V Plus with ...							
		Anchor rod 	fischer internal threaded anchor RG MI 	Reinforcing bar 	fischer rebar anchor FRA 				
Hammer drilling with standard drill bit 	all sizes								
Hammer drilling with hollow drill bit 	Nominal drill bit diameter (d <sub>0</sub> ) 12 mm to 35 mm								
Static and quasi static load, in	uncracked concrete	all sizes	Tables: C1.1 C4.1 C5.1 C6.1 C10.1	all sizes	Tables: C2.1 C4.1 C7.1 C10.2	all sizes	Tables: C3.1 C4.1 C8.1 C11.1	all sizes	Tables: C3.2 C4.1 C9.1 C11.2
	cracked concrete	M8 to M30		..2)		φ 10 to φ 28			
Seismic performance category	C1 <sup>1)</sup>	M10 to M30	Tables: C12.1 C13.1 C14.1	..2)		..2)		..2)	
	C2 <sup>1)</sup>	M12 M16 M20	Tables: C12.1 C13.1 C15.1						
Use category	I1 dry or wet concrete	all sizes							
	I2 water filled hole	M12 to M30		all sizes		..2)		..2)	
Installation direction	D3 (downward and horizontal and upwards (e.g. overhead) installation)								
Installation temperature	T <sub>i,min</sub> = -10 °C to T <sub>i,max</sub> = +40 °C								
In-service temperature	Temperature range I	-40 °C to +80 °C		(max. short term temperature +80 °C; max. long term temperature +50 °C)					
	Temperature range II	-40 °C to +120 °C		(max. short term temperature +120 °C; max. long term temperature +72 °C)					

<sup>1)</sup> Not for FIS VW Plus High Speed and FIS VS Plus Low Speed

<sup>2)</sup> No performance assessed

fischer injection system FIS V Plus

**Intended use**  
Specifications (part 1)

**Annex B 1**

Appendix 9 / 35

## Specifications of intended use (part 2)

### Base materials:

- Compacted reinforced or unreinforced normal weight concrete without fibres of strength classes C20/25 to C50/60 according to EN 206:2013+A1:2016

### Use conditions (Environmental conditions):

- Structures subject to dry internal conditions (zinc coated steel, stainless steel or high corrosion resistant steel).
- For all other conditions according to EN1993-1-4:2015 corresponding to corrosion resistance classes to Annex A 6 Table A6.1.

### Design:

- Anchorages have to be designed by a responsible engineer with experience of concrete anchor design.
- Verifiable calculation notes and drawings are to be prepared taking account of the loads to be anchored. The position of the anchor is indicated on the design drawings (e. g. position of the anchor relative to reinforcement or to supports, etc.).
- Anchorages are designed in accordance with: EN 1992-4:2018 and EOTA Technical Report TR 055, Edition February 2018.

### Installation:

- Anchor installation is to be carried out by appropriately qualified personnel and under the supervision of the person responsible for technical matters of the site
- In case of aborted hole: The hole shall be filled with mortar
- Anchorage depth should be marked and adhered to on installation
- Overhead installation is allowed

fischer injection system FIS V Plus

**Intended use**  
Specifications (part 2)

**Annex B 2**

Appendix 10 / 35

**Table B3.1:** Installation parameters for anchor rods <sup>1)</sup>

Anchor rods		Thread	M6	M8	M10	M12	M16	M20	M24	M27	M30	
Width across flats	SW	[mm]	10	13	17	19	24	30	36	41	46	
Nominal drill hole diameter	d <sub>0</sub>		8	10	12	14	18	24	28	30	35	
Drill hole depth	h <sub>0</sub>		h <sub>0</sub> = h <sub>ef</sub>									
Effective embedment depth	h <sub>ef, min</sub>		50	60	60	70	80	90	96	108	120	
	h <sub>ef, max</sub>		72	160	200	240	320	400	480	540	600	
Minimum spacing and minimum edge distance	S <sub>min</sub> = C <sub>min</sub>		40	40	45	55	65	85	105	125	140	
Diameter of the clearance hole of the fixture	pre-positioned installation d <sub>r</sub>		7	9	12	14	18	22	26	30	33	
	push through installation d <sub>r</sub>		9	12	14	16	20	26	30	33	40	
Minimum thickness of concrete member	h <sub>min</sub>		h <sub>ef</sub> + 30 (≥100)					h <sub>ef</sub> + 2d <sub>0</sub>				
Maximum installation torque	max T <sub>inst</sub>		[Nm]	5	10	20	40	60	120	150	200	300

<sup>1)</sup> minimum spacing and minimum edge distance see Annex B 4

**fischer anchor rod**

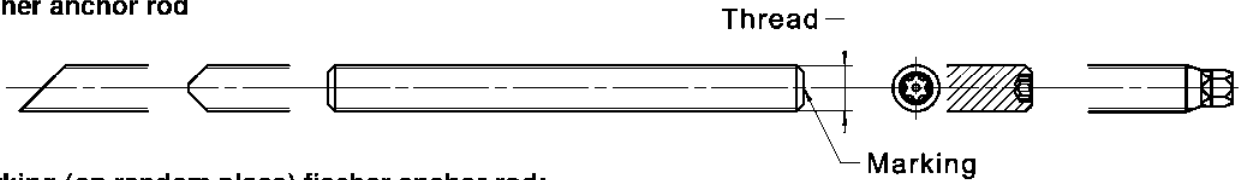

**Marking (on random place) fischer anchor rod:**

Steel zinc plated PC <sup>1)</sup> 8.8	• or +	Steel hot-dip PC <sup>1)</sup> 8.8	•
High corrosion resistant steel HCR PC <sup>1)</sup> 50	•	High corrosion resistant steel HCR PC <sup>1)</sup> 70	-
High corrosion resistant steel HCR PC <sup>1)</sup> 80	(	Stainless steel R property class 50	~
Stainless steel R property class 80	*		

Alternatively: Colour coding according to DIN 976-1: 2016

<sup>1)</sup> PC = property class

**Installation conditions:**

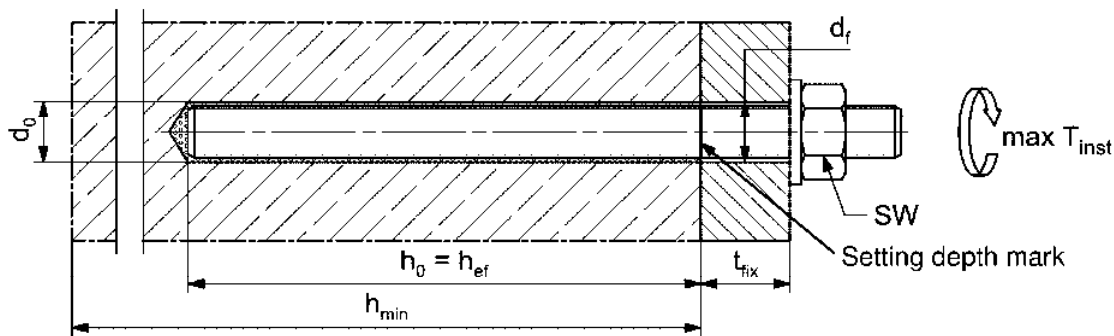

**Commercial standard threaded rods, washers and hexagon nuts may also be used if the following requirements are fulfilled:**

- Materials, dimensions and mechanical properties according to Annex A 6, Table A6.1
- Inspection certificate 3.1 according to EN 10204:2004, the documents have to be stored
- Setting depth is marked

Figures not to scale

fischer injection system FIS V Plus

**Intended use**  
Installation parameters anchor rods

**Annex B 3**

Appendix 11 / 35

**Table B4.1: Minimum spacing and minimum edge distance for anchor rods, reinforcing bars and fischer rebar anchor FRA**

<b>Anchor rods</b>			<b>M6</b>	<b>M8</b>	<b>M10</b>	<b>M12</b>	<b>-</b>	<b>M16</b>
<b>Reinforcing bars / FRA (nominal diameter)</b>		$\phi$	<b>-</b>	<b>8</b>	<b>10</b>	<b>12</b>	<b>14</b>	<b>16</b>
<b>Minimum edge distance</b>								
Uncracked / cracked concrete	$C_{min}$	[mm]	40	40	45	45	45	50
Minimum spacing	$S_{min}$		according to Annex B 5					
<b>Minimum spacing</b>								
Uncracked / cracked concrete	$S_{min}$	[mm]	40	40	45	55	60	65
Minimum edge distance	$C_{min}$		according to Annex B 5					
<b>Required projecting area</b>								
Uncracked concrete	$A_{sp,req}$	[1000	8,0	8,0	13,0	22,0	23,0	24,0
Cracked concrete		mm <sup>2</sup> ]	6,5	6,5	10	16,5	17,5	18,5
<b>Anchor rods</b>			<b>M20</b>	<b>M24</b>	<b>-</b>	<b>M27</b>	<b>-</b>	<b>M30</b>
<b>Reinforcing bars / FRA (nominal diameter)</b>		$\phi$	<b>20</b>	<b>-</b>	<b>25</b>	<b>-</b>	<b>28</b>	<b>-</b>
<b>Minimum edge distance</b>								
Uncracked / cracked concrete	$C_{min}$	[mm]	55	60	75	75	80	80
Minimum spacing	$S_{min}$		according to Annex B 5					
<b>Minimum spacing</b>								
Uncracked / cracked concrete	$S_{min}$	[mm]	85	105	120	120	140	140
Minimum edge distance	$C_{min}$		according to Annex B 5					
<b>Required projecting area</b>								
Uncracked concrete	$A_{sp,req}$	[1000	38,5	40	47,5	47,5	64	64
Cracked concrete		mm <sup>2</sup> ]	29,5	30,5	36,5	36,5	49	49

**Splitting failure** for minimum edge distance and spacing in dependence of the effective embedment depth  $h_{ef}$ .

For the calculation of minimum spacing and minimum edge distance of anchors in combination with different embedment depths and thicknesses of concrete members the following equation shall be fulfilled:

$$A_{sp,req} < A_{sp,t}$$

$A_{sp,req}$  = required projecting area

$A_{sp,t} = A_{sp,ef}$  = effective projecting area (according to Annex B 5)

fischer injection system FIS V Plus

**Intended use**

Minimum spacing and edge distance for anchor rods, reinforcing bars and fischer rebar anchor FRA

**Annex B 4**

Appendix 12 / 35

**Table B5.1:** Effective projecting area  $A_{sp,t}$  with concrete member thickness  $h > h_{ef} + 1,5 \cdot c$  and  $h \geq h_{min}$

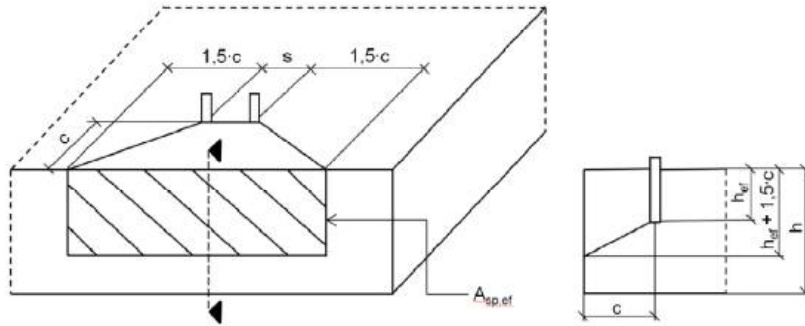

Single anchor	$A_{sp,t} = (3 \cdot c) \cdot (h_{ef} + 1,5 \cdot c)$	[mm <sup>2</sup> ]	with $c \geq c_{min}$
Group of anchors with $s > 3 \cdot c$	$A_{sp,t} = (6 \cdot c) \cdot (h_{ef} + 1,5 \cdot c)$	[mm <sup>2</sup> ]	
Group of anchors with $s \leq 3 \cdot c$	$A_{sp,t} = (3 \cdot c + s) \cdot (h_{ef} + 1,5 \cdot c)$	[mm <sup>2</sup> ]	with $c \geq c_{min}$ and $s \geq s_{min}$

**Table B5.2:** Effekive projecting area  $A_{sp,t}$  with concrete member thickness  $h \leq h_{ef} + 1,5 \cdot c$  and  $h \geq h_{min}$

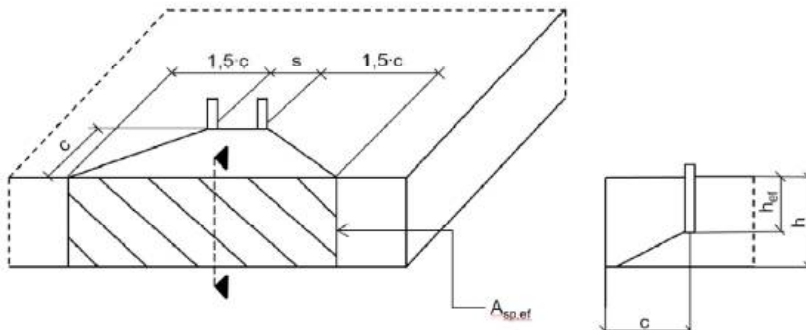

Single anchor	$A_{sp,t} = 3 \cdot c \cdot \text{existing } h$	[mm <sup>2</sup> ]	with $c \geq c_{min}$
Group of anchors with $s > 3 \cdot c$	$A_{sp,t} = 6 \cdot c \cdot \text{existing } h$	[mm <sup>2</sup> ]	
Group of anchors with $s \leq 3 \cdot c$	$A_{sp,t} = (3 \cdot c + s) \cdot \text{existing } h$	[mm <sup>2</sup> ]	with $c \geq c_{min}$ and $s \geq s_{min}$

Edge distance and axial spacing shall be rounded up to at least 5 mm

Figures not to scale

fischer injection system FIS V Plus

**Intended use**

Minimum thickness of concrete member for anchor rods and reinforcing bars, minimum spacing and edge distance

**Annex B 5**

Appendix 13 / 35

**Table B6.1: Installation parameters for fischer internal threaded anchors RG MI**

Internal threaded anchors RG MI		Thread	M8	M10	M12	M16	M20
Diameter of anchor	$d_{nom} = d_H$	[mm]	12	16	18	22	28
Nominal drill hole diameter	$d_0$		14	18	20	24	32
Drill hole depth	$h_0$		$h_0 = h_{ef} = L_H$				
Effective embedment depth ( $h_{ef} = L_H$ )	$h_{ef}$		90	90	125	160	200
Minimum spacing and minimum edge distance	$s_{min}$ = $c_{min}$		55	65	75	95	125
Diameter of clearance hole in the fixture	$d_f$		9	12	14	18	22
Minimum thickness of concrete member	$h_{min}$		120	125	165	205	260
Maximum screw-in depth	$l_{E,max}$		18	23	26	35	45
Minimum screw-in depth	$l_{E,min}$		8	10	12	16	20
Maximum installation torque	$\max T_{inst}$		[Nm]	10	20	40	80

**fischer internal threaded anchor RG MI**

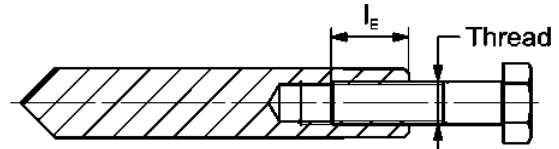
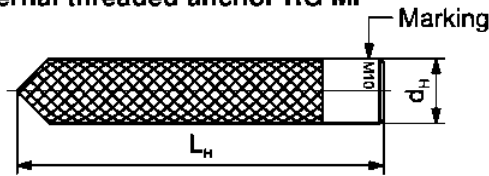

**Marking:**

Anchor size e. g.: **M10**

Stainless steel → additional **R**; e.g.: **M10 R**

High corrosion resistant steel → additional **HCR**; e.g.: **M10 HCR**

Retaining bolt or threaded rods (including nut and washer) must comply with the appropriate material and strength class of Annex A 6, Table A6.1

**Installation conditions:**

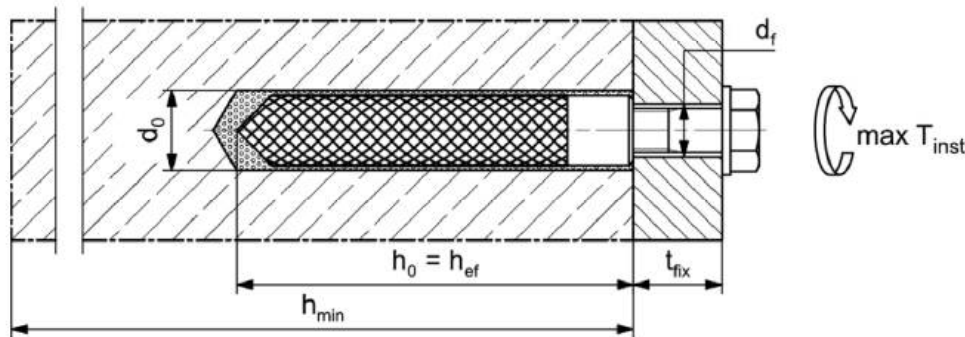

Figures not to scale

fischer injection system FIS V Plus

**Intended use**

Installation parameters internal threaded anchors RG MI

**Annex B 6**

Appendix 14 / 35



**Table B7.1: Installation parameters for reinforcing bars <sup>1)</sup>**

Nominal diameter of the bar		$\phi$	8 <sup>2)</sup>		10 <sup>2)</sup>		12 <sup>2)</sup>		14	16	20	25	28
Nominal drill hole diameter	$d_0$	[mm]	10	12	12	14	14	16	18	20	25	30	35
Drill hole depth	$h_0$		$h_0 = h_{ef}$										
Effective embedment depth	$h_{ef,min}$		60	60	70	75	80	90	100	112			
	$h_{ef,max}$		160	200	240	280	320	400	500	560			
Minimum spacing and minimum edge distance	$s_{min}$ = $c_{min}$		40	45	55	60	65	85	110	130			
Minimum thickness of concrete member	$h_{min}$	$h_{ef} + 30$ ( $\geq 100$ )					$h_{ef} + 2d_0$						

<sup>1)</sup> minimum spacing and minimum edge distance see Annex B 4

<sup>2)</sup> Both drill hole diameters can be used

**Reinforcing bar**



- The minimum value of related rib area  $f_{R,min}$  must fulfil the requirements of EN 1992-1-1:2004+AC:2010
- The rib height must be within the range:  $0,05 \cdot \phi \leq h_{rib} \leq 0,07 \cdot \phi$   
( $\phi$  = Nominal diameter of the bar,  $h_{rib}$  = rib height)

**Installation conditions:**

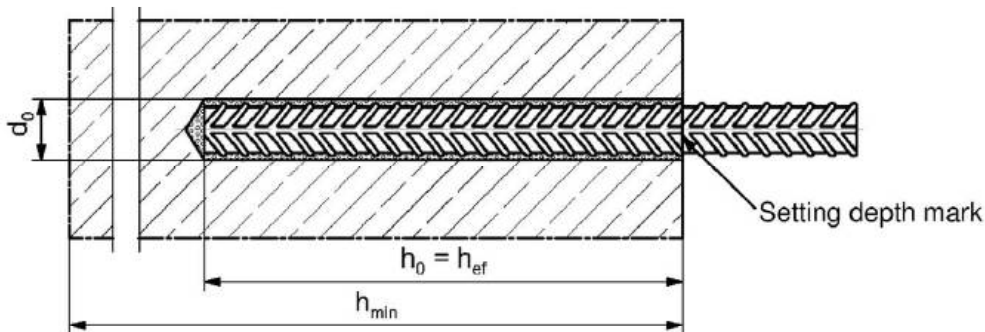

Figures not to scale

fischer injection system FIS V Plus

**Intended use**  
Installation parameters reinforcing bars

**Annex B 7**

Appendix 15 / 35

**Table B8.1: Installation parameters for fischer rebar anchor FRA <sup>1)</sup>**

Rebar anchor FRA		Thread	M12 <sup>2)</sup>	M16	M20	M24
Nominal diameter of the bar	$\phi$	[mm]	12	16	20	25
Width across flats	SW		19	24	30	36
Nominal drill hole diameter	$d_0$		14	16	20	30
Drill hole depth	$h_0$		$h_{ef} + l_e$			
Effective embedment depth	$h_{ef,min}$		70	80	90	96
	$h_{ef,max}$		140	220	300	380
Distance concrete surface to welded joint	$l_e$		100			
Minimum spacing and minimum edge distance	$s_{min}$ =		55	65	85	105
	$c_{min}$					
Diameter of clearance hole in the fixture	pre-positioned anchorage $\leq d_f$		14	18	22	26
	push through anchorage $\leq d_f$	18	22	26	32	
Minimum thickness of concrete member	$h_{min}$	$h_0 + 30$	$h_0 + 2d_0$			
Maximum installation torque	$\max T_{inst}$	[Nm]	40	60	120	150

<sup>1)</sup> minimum spacing and minimum edge distance see Annex B 5

<sup>2)</sup> Both drill hole diameters can be used

**fischer rebar anchor FRA**

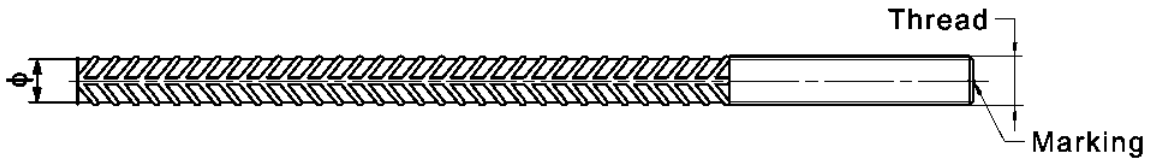

Marking frontal e.g:

- FRA (for stainless steel);
- FRA HCR (for high corrosion resistant steel)

**Installation conditions:**

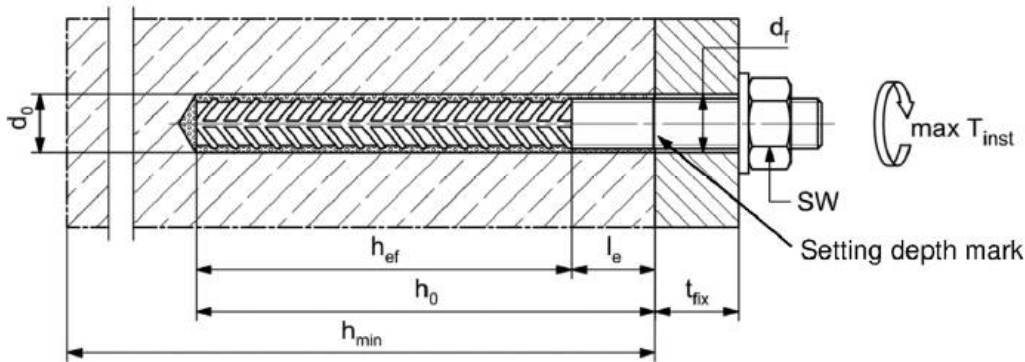

Figures not to scale

fischer injection system FIS V Plus

**Intended use**  
Installation parameters rebar anchor FRA

**Annex B 8**

Appendix 16 / 35

**Table B9.1:** Parameters of the **cleaning brush BS** (steel brush with steel bristles)

The size of the cleaning brush refers to the drill hole diameter

Nominal drill hole diameter	$d_0$	[mm]	8	10	12	14	16	18	20	24	25	28	30	35
Steel brush diameter	$d_b$		9	11	14	16	20		25	26	27	30	40	

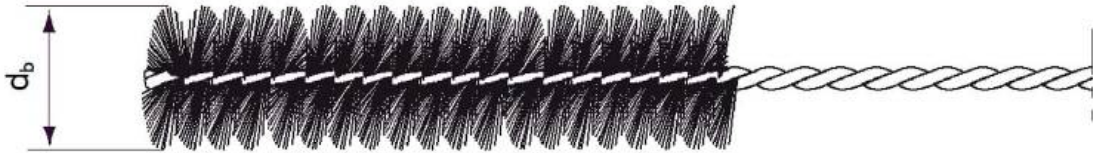

**Table B9.2** **Maximum processing** time of the mortar and **minimum curing** time  
(During the curing time of the mortar the concrete temperature may not fall below the listed minimum temperature)

Temperature at anchoring base [°C]	Maximum processing time $t_{work}$			Minimum curing time <sup>1)</sup> $t_{cure}$		
	FIS VW Plus High Speed	FIS V Plus	FIS VS Plus Low Speed	FIS VW Plus High Speed	FIS V Plus	FIS VS Plus Low Speed
-10 to -5 <sup>2)</sup>	-	-	-	12 h	-	-
> -5 to 0 <sup>2)</sup>	5 min	-	-	3 h	24 h	-
> 0 to 5 <sup>2)</sup>	5 min	13 min	-	3 h	3 h	6 h
> 5 to 10	3 min	9 min	20 min	50 min	90 min	3 h
> 10 to 20	1 min	5 min	10 min	30 min	60 min	2 h
> 20 to 30	-	4 min	6 min	-	45 min	60 min
> 30 to 40	-	2 min	4 min	-	35 min	30 min

<sup>1)</sup> In wet concrete or water filled holes the curing times must be doubled

<sup>2)</sup> Minimal cartridge temperature +5°C

fischer injection system FIS V Plus

**Intended use**



Cleaning brush (steel brush)  
Processing time and curing time

**Annex B 9**

Appendix 17 / 35

# Installation instructions part 1

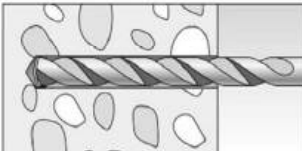
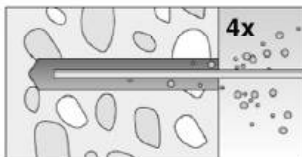
## Drilling and cleaning the hole (hammer drilling with standard drill bit)

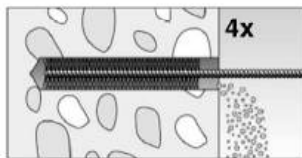
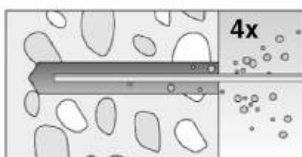
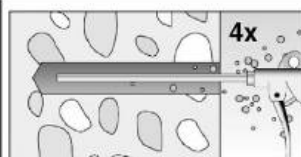
1		<p>Drill the hole. Nominal drill hole diameter <math>d_0</math> and drill hole depth <math>h_0</math> see <b>tables B3.1, B6.1, B7.1, B8.1</b></p>	
2		<p>Clean the drill hole: For <math>h_{ef} \leq 12d</math> and <math>d_0 &lt; 18</math> mm blow out the hole four times by hand</p>	 <p>For <math>h_{ef} &gt; 12d</math> and / or <math>d_0 \geq 18</math> mm blow out the hole four times with oil-free compressed air (<math>p \geq 6</math> bar)</p>
3		<p>Brush the drill hole four times. For drill hole diameter <math>\geq 30</math> mm use a power drill. For deep holes use an extension. Corresponding brushes see <b>table B9.1</b></p>	
4		<p>Clean the drill hole: For <math>h_{ef} \leq 12d</math> and <math>d_0 &lt; 18</math> mm blow out the hole four times by hand</p>	 <p>For <math>h_{ef} &gt; 12d</math> and / or <math>d_0 \geq 18</math> mm blow out the hole four times with oil-free compressed air (<math>p \geq 6</math> bar)</p>

Go to step 5

## Drilling and cleaning the hole (hammer drilling with hollow drill bit)

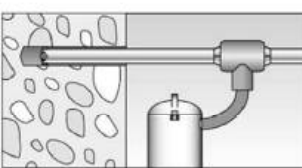
1		<p>Check a suitable hollow drill (see <b>table B1.1</b>) for correct operation of the dust extraction</p>	
2		<p>Use a suitable dust extraction system, e.g. fischer FVC 35 M or a comparable dust extraction system with equivalent performance data</p> <p>Drill the hole with hollow drill bit. The dust extraction system has to extract the drill dust nonstop during the drilling process and must be adjusted to maximum power. Nominal drill hole diameter <math>d_0</math> and drill hole depth <math>h_0</math> see <b>tables B3.1, B6.1, B7.1, B8.1</b></p>	

Go to step 5

fischer injection system FIS V Plus





**Intended use**  
Installation instructions part 1

**Annex B 10**

Appendix 18 / 35

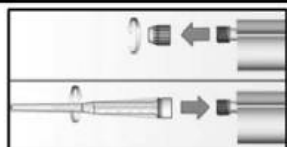
## Installation instructions part 2

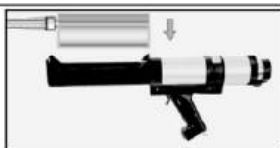
### Preparing the cartridge

5		Remove the sealing cap Screw on the static mixer (the spiral in the static mixer must be clearly visible)
6		 Place the cartridge into the dispenser
7		 Extrude approximately 10 cm of material out until the resin is evenly grey in colour. Do not use mortar that is not uniformly grey

Go to step 8

### Injection of the mortar

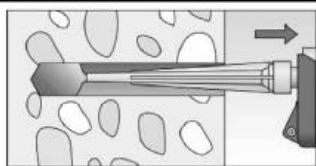
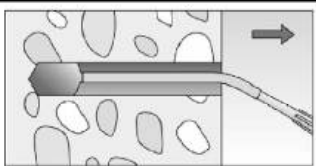
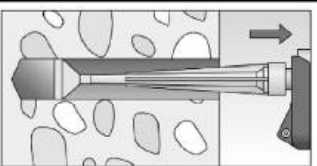
8	 <p>Fill approximately 2/3 of the drill hole with mortar. Always begin from the bottom of the hole and avoid bubbles</p>	 <p>For drill hole depth <math>\geq 150</math> mm use an extension tube</p>	 <p>For overhead installation, deep holes (<math>h_0 &gt; 250</math> mm) or drill hole diameter (<math>d_0 \geq 40</math> mm) use an injection adapter</p>
---	---	--	---

Go to step 9

fischer injection system FIS V Plus





**Intended use**  
Installation instructions part 2

**Annex B 11**

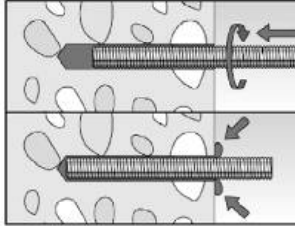
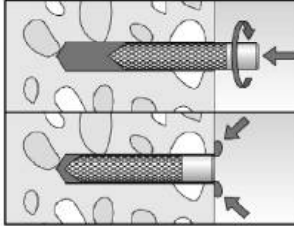

Appendix 19 / 35

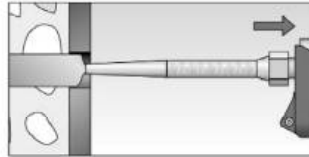
### Installation instructions part 3

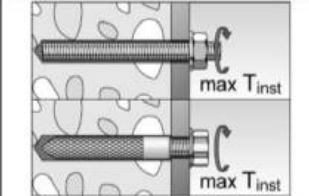
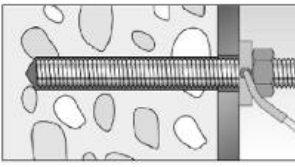
#### Installation of anchor rods or fischer internal threaded anchors RG MI

9			<p>Only use clean and oil-free metal parts. Mark the setting depth of the metal part. Push the anchor rod or fischer internal threaded RG MI anchor down to the bottom of the hole, turning it slightly while doing so. After inserting the metal parts, excess mortar must be emerged around the anchor element.</p>
		<p>For overhead installations support the metal part with wedges (e.g. fischer centering wedges) or fischer overhead clips.</p>	 <p>For push through installation fill the annular gap with mortar</p>
10		<p>Wait for the specified curing time <math>t_{cure}</math> see <b>table B9.2</b></p>	<p>11</p>  <p>Mounting the fixture <math>\max T_{inst}</math> see <b>tables B3.1 and B6.1</b></p>
Option		<p>After the minimum curing time is reached, the gap between metal part and fixture (annular clearance) may be filled with mortar via the fischer filling disc. Compressive strength <math>\geq 50 \text{ N/mm}^2</math> (e.g. fischer injection mortars FIS HB, FIS SB, FIS V, FIS V Plus, FIS EM Plus). ATTENTION: Using fischer filling disc reduces <math>t_{fix}</math> (usable length of the anchor)</p>	

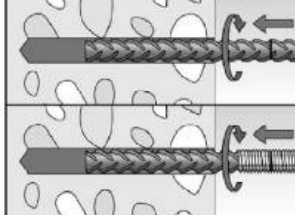
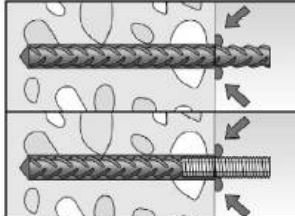
#### Installation reinforcing bars and fischer rebar anchor FRA

9		<p>Only use clean and oil-free reinforcing bars or fischer FRA. Mark the setting depth. Turn while using force to push the reinforcement bar or the fischer FRA into the filled hole up to the setting depth mark.</p>	
		<p>When the setting depth mark is reached, excess mortar must be emerged from the mouth of the drill hole.</p>	
10		<p>Wait for the specified curing time <math>t_{cure}</math> see <b>table B9.2</b></p>	<p>11</p>  <p>Mounting the fixture <math>\max T_{inst}</math> see <b>table B8.1</b></p>

fischer injection system FIS V Plus

**Intended use**  
Installation instructions part 3

**Annex B 12**

Appendix 20 / 35

**Table C1.1: Characteristic values for steel failure under tension / shear load of fischer anchor rods and standard threaded rods**

Anchor rod / standard threaded rod		M6	M8	M10	M12	M16	M20	M24	M27	M30			
<b>Bearing capacity under tension load, steel failure <sup>3)</sup></b>													
Characteristic resistance $N_{Rk,s}$	Steel zinc plated	Property class	4.8	[kN]	8	15(13)	23(21)	33	63	98	141	184	224
			5.8		10	19(17)	29(27)	43	79	123	177	230	281
			8.8		16	29(27)	47(43)	68	126	196	282	368	449
	Stainless steel R and high corrosion resistant steel HCR		50		10	19	29	43	79	123	177	230	281
			70		14	26	41	59	110	172	247	322	393
			80		16	30	47	68	126	196	282	368	449
<b>Partial factors <sup>1)</sup></b>													
Partial factor $\gamma_{Ms,N}$	Steel zinc plated	Property class	4.8	[-]	1,50								
			5.8		1,50								
			8.8		1,50								
	Stainless steel R and high corrosion resistant steel HCR		50		2,86								
			70		1,50 <sup>2)</sup> / 1,87								
			80		1,60								
<b>Bearing capacity under shear load, steel failure <sup>3)</sup></b>													
<b>without lever arm</b>													
Characteristic resistance $V_{Rk,s}^0$	Steel zinc plated	Property class	4.8	[kN]	4	9(8)	14(13)	20	38	59	85	110	135
			5.8		6	11(10)	17(16)	25	47	74	106	138	168
			8.8		8	15(13)	23(21)	34	63	98	141	184	225
	Stainless steel R and high corrosion resistant steel HCR		50		5	9	15	21	39	61	89	115	141
			70		7	13	20	30	55	86	124	161	197
			80		8	15	23	34	63	98	141	184	225
Ductility factor	$k_7$	[-]	1,0										
<b>with lever arm</b>													
Characteristic resistance $M_{Rk,s}^0$	Steel zinc plated	Property class	4.8	[Nm]	6	15(13)	30(27)	52	133	259	448	665	899
			5.8		7	19(16)	37(33)	65	166	324	560	833	1123
			8.8		12	30(26)	60(53)	105	266	519	896	1333	1797
	Stainless steel R and high corrosion resistant steel HCR		50		7	19	37	65	166	324	560	833	1123
			70		10	26	52	92	232	454	784	1167	1573
			80		12	30	60	105	266	519	896	1333	1797
<b>Partial factors <sup>1)</sup></b>													
Partial factor $\gamma_{Ms,V}$	Steel zinc plated	Property class	4.8	[-]	1,25								
			5.8		1,25								
			8.8		1,25								
	Stainless steel R and high corrosion resistant steel HCR		50		2,38								
			70		1,25 <sup>2)</sup> / 1,56								
			80		1,33								
<sup>1)</sup> In absence of other national regulations <sup>2)</sup> Only admissible for high corrosion resist. steel HCR, with $f_{yk} / f_{uk} \geq 0,8$ and $A_5 > 12 \%$ (e.g. fischer anchor rods) <sup>3)</sup> Values in brackets are valid for undersized threaded rods with smaller stress area $A_s$ for hot dip galvanised standard threaded rods according to EN ISO 10684:2004+AC:2009													

fischer injection system FIS V Plus

**Performances**

Characteristic values for steel failure under tension / shear load of fischer anchor rods and standard threaded rods

**Annex C 1**

Appendix 21 / 35

**Table C2.1: Characteristic values for steel failure under tension / shear load of fischer internal threaded anchors RG MI**

fischer internal threaded anchors RG MI			M8	M10	M12	M16	M20	
<b>Bearing capacity under tension load, steel failure</b>								
Charact. resistance with screw	Property class	5.8	[kN]	19	29	43	79	123
		8.8		29	47	68	108	179
		R		26	41	59	110	172
		HCR		26	41	59	110	172
<b>Partial factors<sup>1)</sup></b>								
Partial factors	Property class	5.8	[-]	1,50				
		8.8		1,50				
		R		1,87				
		HCR		1,87				
<b>Bearing capacity under shear load, steel failure</b>								
<b>Without lever arm</b>								
Charact. resistance with screw	Property class	5.8	[kN]	9,2	14,5	21,1	39,2	62,0
		8.8		14,6	23,2	33,7	54,0	90,0
		R		12,8	20,3	29,5	54,8	86,0
		HCR		12,8	20,3	29,5	54,8	86,0
Ductility factor		k <sub>7</sub>	[-]	1,0				
<b>With lever arm</b>								
Charact. resistance with screw	Property class	5.8	[Nm]	20	39	68	173	337
		8.8		30	60	105	266	519
		R		26	52	92	232	454
		HCR		26	52	92	232	454
<b>Partial factors<sup>1)</sup></b>								
Partial factors	Property class	5.8	[-]	1,25				
		8.8		1,25				
		R		1,56				
		HCR		1,56				

<sup>1)</sup> In absence of other national regulations

fischer injection system FIS V Plus

**Performances**

Characteristic values for steel failure under tension / shear load of fischer internal threaded anchor RG MI

**Annex C 2**

Appendix 22 / 35



<b>Table C3.1: Characteristic values for steel failure under tension / shear load of reinforcing bars</b>									
Nominal diameter of the bar	$\phi$	8	10	12	14	16	20	25	28
<b>Bearing capacity under tension load, steel failure</b>									
Characteristic resistance	$N_{Rk,s}$	[kN]	$A_s \cdot f_{uk}^{1)}$						
<b>Bearing capacity under shear load, steel failure</b>									
<b>Without lever arm</b>									
Characteristic resistance	$V^0_{Rk,s}$	[kN]	$0,5 \cdot A_s \cdot f_{uk}^{1)}$						
Ductility factor	$k_7$	[-]	1,0						
<b>With lever arm</b>									
Characteristic resistance	$M^0_{Rk,s}$	[Nm]	$1,2 \cdot W_{el} \cdot f_{uk}^{1)}$						
<sup>1)</sup> $f_{uk}$ or $f_{yk}$ respectively must be taken from the specifications of the reinforcing bar									

<b>Table C3.2: Characteristic values for steel failure under tension / shear load of fischer rebar anchors FRA</b>						
fischer rebar anchor FRA		M12	M16	M20	M24	
<b>Bearing capacity under tension load, steel failure</b>						
Characteristic resistance	$N_{Rk,s}$	[kN]	63	111	173	270
<b>Partial factor<sup>1)</sup></b>						
Partial factor	$\gamma_{Ms,N}$	[-]	1,4			
<b>Bearing capacity under shear load, steel failure</b>						
<b>Without lever arm</b>						
Characteristic resistance	$V^0_{Rk,s}$	[kN]	30	55	86	124
Ductility factor	$k_7$	[-]	1,0			
<b>With lever arm</b>						
Characteristic resistance	$M^0_{Rk,s}$	[Nm]	92	233	454	785
<b>Partial factor<sup>1)</sup></b>						
Partial factor	$\gamma_{Ms,V}$	[-]	1,56			

<sup>1)</sup> In absence of other national regulations

fischer injection system FIS V Plus

**Performances**

Characteristic values for steel failure under tension / shear load of reinforcing bars and fischer rebar anchors FRA

**Annex C 3**

Appendix 23 / 35

<b>Table C4.1: Characteristic values for concrete failure under tension / shear load</b>											
<b>Size</b>			<b>All sizes</b>								
<b>Tension load</b>											
Installation factor		$\gamma_{inst}$	[-]		See annex C 5 to C 12 and C 17 to C18						
<b>Factors for the compressive strength of concrete &gt; C20/25</b>											
Increasing factor for $\tau_{Rk}$	C25/30		$\Psi_c$	[-]	1,05						
	C30/37				1,10						
	C35/45				1,15						
	C40/50				1,19						
	C45/55				1,22						
	C50/60				1,26						
<b>Splitting failure</b>											
Edge distance	$h / h_{ef} \geq 2,0$		$C_{cr,sp}$	[mm]	1,0 $h_{ef}$						
	$2,0 > h / h_{ef} > 1,3$				4,6 $h_{ef}$ - 1,8 h						
	$h / h_{ef} \leq 1,3$				2,26 $h_{ef}$						
Spacing		$S_{cr,sp}$	2 $C_{cr,sp}$								
<b>Concrete failure</b>											
Uncracked concrete		$k_{ucr,N}$	[-]	11,0							
Cracked concrete		$k_{cr,N}$		7,7							
Edge distance		$C_{cr,N}$	[mm]	1,5 $h_{ef}$							
Spacing		$S_{cr,N}$		2 $C_{cr,N}$							
<b>Factors for sustained tension load</b>											
Temperature range			[-]		50 °C / 80 °C			72 °C / 120 °C			
Factor		$\Psi_{sus}^0$	[-]		0,76			0,78			
<b>Shear load</b>											
Installation factor		$\gamma_{inst}$	[-]		1,0						
<b>Concrete pry-out failure</b>											
Factor for pry-out failure		$k_8$	[-]		2,0						
<b>Concrete edge failure</b>											
Effective length of fastener in shear loading		$l_f$	[mm]	for $d_{nom} \leq 24$ mm: min ( $h_{ef}$ ; 12 $d_{nom}$ ) for $d_{nom} > 24$ mm: min ( $h_{ef}$ ; 8 $d_{nom}$ ; 300 mm)							
<b>Calculation diameters</b>											
Size			M6	M8	M10	M12	M16	M20	M24	M27	M30
fisher anchor rods and standard threaded rods		$d_{nom}$	6	8	10	12	16	20	24	27	30
fisher internal threaded anchors RG MI		$d_{nom}$	-1)	12	16	18	22	28	-1)	-1)	-1)
fisher rebar anchor FRA		$d_{nom}$	-1)	-1)	-1)	12	16	20	25	-1)	-1)
Size (nominal diameter of the bar)		$\phi$	8	10	12	14	16	20	25	28	
Reinforcing bar		$d_{nom}$	[mm]	8	10	12	14	16	20	25	28
1) Size of anchor type not part of the assessment											
fisher injection system FIS V Plus									<b>Annex C 4</b> Appendix 24 / 35		
<b>Performances</b> Characteristic values for concrete failure under tension / shear load											

**Table C5.1: Characteristic values for combined pull-out and concrete failure for fischer anchor rods and standard threaded rods in hammer drilled holes; uncracked or cracked concrete; working life 50 years**

Anchor rod / standard threaded rod		M6	M8	M10	M12	M16	M20	M24	M27	M30	
<b>Uncracked concrete</b>											
<b>Characteristic bond resistance in uncracked concrete C20/25</b>											
Hammer-drilling with standard drill bit or hollow drill bit (dry or wet concrete)											
Temperature range	I: 50 °C / 80 °C	$\tau_{Rk,ucr}$ [N/mm <sup>2</sup> ]	9,0	16,0	16,0	15,0	14,0	12,0	11,0	10,0	9,0
	II: 72 °C / 120 °C		6,5	15,0	14,0	13,0	12,0	11,0	9,0	8,0	8,0
Hammer-drilling with standard drill bit or hollow drill bit (water filled hole)											
Temperature range	I: 50 °C / 80 °C	$\tau_{Rk,ucr}$ [N/mm <sup>2</sup> ]	-1)	-1)	-1)	9,5	8,5	8,0	7,5	7,0	7,0
	II: 72 °C / 120 °C		-1)	-1)	-1)	7,5	7,0	6,5	6,0	6,0	6,0
<b>Installation factors</b>											
Dry or wet concrete	$\gamma_{inst}$	[-]	1,0								
Water filled hole	$\gamma_{inst}$	[-]	-1)	-1)	-1)	1,2					
<b>Cracked concrete</b>											
<b>Characteristic bond resistance in cracked concrete C20/25</b>											
Hammer-drilling with standard drill bit or hollow drill bit (dry or wet concrete)											
Temperature range	I: 50 °C / 80 °C	$\tau_{Rk,cr}$ [N/mm <sup>2</sup> ]	-1)	5,5	6,0	6,5	6,0	5,5	5,0	5,0	4,5
	II: 72 °C / 120 °C		-1)	4,5	5,0	6,0	5,5	5,0	4,5	4,0	4,0
Hammer-drilling with standard drill bit or hollow drill bit (water filled hole)											
Temperature range	I: 50 °C / 80 °C	$\tau_{Rk,cr}$ [N/mm <sup>2</sup> ]	-1)	-1)	-1)	5,0	5,0	4,5	4,0	3,5	3,5
	II: 72 °C / 120 °C		-1)	-1)	-1)	4,0	4,0	4,0	3,5	3,0	3,0
<b>Installation factors</b>											
Dry or wet concrete	$\gamma_{inst}$	[-]	1,0								
Water filled hole	$\gamma_{inst}$	[-]	-1)	-1)	-1)	1,2					

<sup>1)</sup> No performance assessed

fischer injection system FIS V Plus

**Performances**

Characteristic values for combined pull-out and concrete failure for fischer anchor rod and standard threaded rods; working life 50 years

**Annex C 5**

Appendix 25 / 35

<b>Table C6.1: Characteristic values for combined pull-out and concrete failure for fischer anchor rods and standard threaded rods in hammer drilled holes; uncracked or cracked concrete; working life 100 years</b>												
Anchor rod / standard threaded rod			M6	M8	M10	M12	M16	M20	M24	M27	M30	
<b>Combined pullout and concrete cone failure</b>												
Calculation diameter		d	[mm]	6	8	10	12	16	20	24	27	30
<b>Uncracked concrete</b>												
<b>Characteristic bond resistance in uncracked concrete C20/25</b>												
Hammer-drilling with standard drill bit or hollow drill bit (dry or wet concrete)												
Tem- perature range	I: 50 °C / 80 °C		$\tau_{Rk,100,ucr}$ [N/mm <sup>2</sup> ]	- <sup>1)</sup>	16,0	16,0	15,0	14,0	12,0	11,0	10,0	9,0
	II: 72 °C / 120 °C			- <sup>1)</sup>	15,0	14,0	13,0	12,0	11,0	9,0	8,0	8,0
Hammer-drilling with standard drill bit or hollow drill bit (water filled hole)												
Tem- perature range	I: 50 °C / 80 °C		$\tau_{Rk,100,ucr}$ [N/mm <sup>2</sup> ]	- <sup>1)</sup>	- <sup>1)</sup>	- <sup>1)</sup>	9,5	8,5	8,0	7,5	7,0	7,0
	II: 72 °C / 120 °C			- <sup>1)</sup>	- <sup>1)</sup>	- <sup>1)</sup>	7,5	7,0	6,5	6,0	6,0	6,0
<b>Installation factors</b>												
Dry or wet concrete		$\gamma_{inst}$	[-]	1,0								
Water filled hole		$\gamma_{inst}$	[-]	- <sup>1)</sup>	- <sup>1)</sup>	- <sup>1)</sup>	1,2					
<b>Cracked concrete</b>												
<b>Characteristic bond resistance in cracked concrete C20/25</b>												
Hammer-drilling with standard drill bit or hollow drill bit (dry or wet concrete)												
Tem- perature range	I: 50 °C / 80 °C		$\tau_{Rk,100,cr}$ [N/mm <sup>2</sup> ]	- <sup>1)</sup>	5,0	5,5	5,5	5,5	5,5	5,0	5,0	4,5
	II: 72 °C / 120 °C			- <sup>1)</sup>	4,5	5,0	5,0	5,0	5,0	4,0	4,0	4,0
Hammer-drilling with standard drill bit or hollow drill bit (water filled hole)												
Tem- perature range	I: 50 °C / 80 °C		$\tau_{Rk,100,cr}$ [N/mm <sup>2</sup> ]	- <sup>1)</sup>	- <sup>1)</sup>	- <sup>1)</sup>	4,5	4,5	4,5	4,0	3,5	3,5
	II: 72 °C / 120 °C			- <sup>1)</sup>	- <sup>1)</sup>	- <sup>1)</sup>	4,0	4,0	4,0	3,5	3,0	3,0
<b>Installation factors</b>												
Dry or wet concrete		$\gamma_{inst}$	[-]	1,0								
Water filled hole		$\gamma_{inst}$	[-]	- <sup>1)</sup>	- <sup>1)</sup>	- <sup>1)</sup>	1,2					
<sup>1)</sup> No performance assessed												

fischer injection system FIS V Plus

**Performances**

Characteristic values for combined pull-out and concrete failure for fischer anchor rod and standard threaded rods; working life 100 years

**Annex C 6**

Appendix 26 / 35

**Table C7.1: Characteristic values for combined pull-out and concrete failure for fischer internal threaded anchors RG MI in hammer drilled holes; uncracked concrete; working life 50 years**

Internal threaded anchor RG MI			M8	M10	M12	M16	M20	
<b>Combined pullout and concrete cone failure</b>								
Calculation diameter	d	[mm]	12	16	18	22	28	
<b>Uncracked concrete</b>								
<b>Characteristic bond resistance in uncracked concrete C20/25</b>								
Hammer-drilling with standard drill bit or hollow drill bit (dry or wet concrete)								
Tem- perature range	I: 50 °C / 80 °C	$\tau_{Rk,ucr}$	[N/mm <sup>2</sup> ]	10,5	10,0	9,5	9,0	8,5
	II: 72 °C / 120 °C			9,0	8,0	8,0	7,5	7,0
Hammer-drilling with standard drill bit or hollow drill bit (water filled hole)								
Tem- perature range	I: 50 °C / 80 °C	$\tau_{Rk,ucr}$	[N/mm <sup>2</sup> ]	10,0	9,0	9,0	8,5	8,0
	II: 72 °C / 120 °C			7,5	6,5	6,5	6,0	6,0
<b>Installation factors</b>								
Dry or wet concrete		$\gamma_{inst}$					1,0	
Water filled hole			[-]				1,2	

fischer injection system FIS V Plus

**Performances**

Characteristic values for combined pull-out and concrete failure for fischer internal threaded anchors RG MI; working life 50 years

**Annex C 7**

Appendix 27 / 35

**Table C8.1: Characteristic values for combined pull-out and concrete failure for reinforcing bars in hammer drilled holes; uncracked or cracked concrete; working life 50 years**

<b>Nominal diameter of the bar</b>		$\phi$	<b>8</b>	<b>10</b>	<b>12</b>	<b>14</b>	<b>16</b>	<b>20</b>	<b>25</b>	<b>28</b>		
<b>Combined pullout and concrete cone failure</b>												
Calculation diameter		d	[mm]	8	10	12	14	16	20	25	28	
<b>Uncracked concrete</b>												
<b>Characteristic bond resistance in uncracked concrete C20/25</b>												
<u>Hammer-drilling with standard drill bit or hollow drill bit (dry or wet concrete)</u>												
Tem- perature range	I: 50 °C / 80 °C		$\tau_{Rk,ucr}$	[N/mm <sup>2</sup> ]	11,0	11,0	11,0	10,0	10,0	9,5	9,0	8,5
	II: 72 °C / 120 °C				9,5	9,5	9,0	8,5	8,5	8,0	7,5	7,0
<b>Installation factor</b>												
Dry or wet concrete		$\gamma_{inst}$	[-]	1,0								
<b>Cracked concrete</b>												
<b>Characteristic bond resistance in cracked concrete C20/25</b>												
<u>Hammer-drilling with standard drill bit or hollow drill bit (dry or wet concrete)</u>												
Tem- perature range	I: 50 °C / 80 °C		$\tau_{Rk,cr}$	[N/mm <sup>2</sup> ]	- <sup>1)</sup>	3,0	5,0	5,0	5,0	4,5	4,0	4,0
	II: 72 °C / 120 °C				- <sup>1)</sup>	3,0	4,5	4,5	4,5	4,0	3,5	3,5
<b>Installation factor</b>												
Dry or wet concrete		$\gamma_{inst}$	[-]	1,0								

<sup>1)</sup> No performance assessed

fischer injection system FIS V Plus

**Performances**

Characteristic values for combined pull-out and concrete failure for reinforcing bars; working life 50 years

**Annex C 8**

Appendix 28 / 35

<b>Table C9.1: Characteristic values for combined pull-out and concrete failure for fischer rebar anchors FRA in hammer drilled holes; uncracked or cracked concrete; working life 50 years</b>								
fischer rebar anchor FRA		M12	M16	M20	M24			
<b>Combined pullout and concrete cone failure</b>								
Calculation diameter	d	[mm]	12	16	20	25		
<b>Uncracked concrete</b>								
<b>Characteristic bond resistance in uncracked concrete C20/25</b>								
Hammer-drilling with standard drill bit or hollow drill bit (dry or wet concrete)								
Tem- perature range	I: 50 °C / 80 °C		$\tau_{Rk,ucr}$	[N/mm <sup>2</sup> ]	11,0	10,0	9,5	9,5
	II: 72 °C / 120 °C				9,0	8,5	8,0	7,5
<b>Installation factors</b>								
Dry or wet concrete		$\gamma_{inst}$	[-]	1,0				
<b>Cracked concrete</b>								
<b>Characteristic bond resistance in cracked concrete C20/25</b>								
Hammer-drilling with standard drill bit or hollow drill bit (dry or wet concrete)								
Tem- perature range	I: 50 °C / 80 °C		$\tau_{Rk,cr}$	[N/mm <sup>2</sup> ]	5,0	5,0	4,5	4,0
	II: 72 °C / 120 °C				4,5	4,5	4,0	3,5
<b>Installation factors</b>								
Dry or wet concrete		$\gamma_{inst}$	[-]	1,0				

fischer injection system FIS V Plus

**Performances**

Characteristic values for combined pull-out and concrete failure for fischer rebar anchors FRA; working life 50 years

**Annex C 9**

Appendix 29 / 35

**Table C10.1: Displacements for anchor rods**

Anchor rod	M6	M8	M10	M12	M16	M20	M24	M27	M30	
<b>Displacement-Factors for tension load<sup>1)</sup></b>										
<b>Uncracked concrete; Temperature range I, II</b>										
$\delta_{N0}$ -Factor	[mm/(N/mm <sup>2</sup> )]	0,09	0,09	0,09	0,10	0,10	0,10	0,10	0,11	0,12
$\delta_{N\infty}$ -Factor		0,10	0,10	0,10	0,12	0,12	0,12	0,13	0,13	0,14
<b>Cracked concrete; Temperature range I, II</b>										
$\delta_{N0}$ -Factor	[mm/(N/mm <sup>2</sup> )]	- <sup>3)</sup>	0,12	0,12	0,12	0,13	0,13	0,13	0,14	0,15
$\delta_{N\infty}$ -Factor		- <sup>3)</sup>	0,25	0,27	0,30	0,30	0,30	0,35	0,35	0,40
<b>Displacement-Factors for shear load<sup>2)</sup></b>										
<b>Uncracked or cracked concrete; Temperature range I, II</b>										
$\delta_{V0}$ -Factor	[mm/kN]	0,11	0,11	0,11	0,10	0,10	0,09	0,09	0,08	0,07
$\delta_{V\infty}$ -Factor		0,12	0,12	0,12	0,11	0,11	0,10	0,10	0,09	0,09
1) Calculation of effective displacement: $\delta_{N0} = \delta_{N0}\text{-Factor} \cdot \tau_{Ed}$ $\delta_{N\infty} = \delta_{N\infty}\text{-Factor} \cdot \tau_{Ed}$ ( $\tau_{Ed}$ : Design value of the applied tensile stress)					2) Calculation of effective displacement: $\delta_{V0} = \delta_{V0}\text{-Factor} \cdot V_{Ed}$ $\delta_{V\infty} = \delta_{V\infty}\text{-Factor} \cdot V_{Ed}$ ( $V_{Ed}$ : Design value of the applied shear force)					
3) No performance assessed										

**Table C10.2: Displacements for fischer internal threaded anchors RG MI**

Internal threaded anchor RG MI	M8	M10	M12	M16	M20	
<b>Displacement-Factors for tension load<sup>1)</sup></b>						
<b>Uncracked concrete; Temperature range I, II</b>						
$\delta_{N0}$ -Factor	[mm/(N/mm <sup>2</sup> )]	0,10	0,11	0,12	0,13	0,14
$\delta_{N\infty}$ -Factor		0,13	0,14	0,15	0,16	0,18
<b>Displacement-Factors for shear load<sup>2)</sup></b>						
<b>Uncracked concrete; Temperature range I, II</b>						
$\delta_{V0}$ -Factor	[mm/kN]	0,12	0,12	0,12	0,12	0,12
$\delta_{V\infty}$ -Factor		0,14	0,14	0,14	0,14	0,14
1) Calculation of effective displacement: $\delta_{N0} = \delta_{N0}\text{-Factor} \cdot \tau_{Ed}$ $\delta_{N\infty} = \delta_{N\infty}\text{-Factor} \cdot \tau_{Ed}$ ( $\tau_{Ed}$ : Design value of the applied tensile stress)			2) Calculation of effective displacement: $\delta_{V0} = \delta_{V0}\text{-Factor} \cdot V_{Ed}$ $\delta_{V\infty} = \delta_{V\infty}\text{-Factor} \cdot V_{Ed}$ ( $V_{Ed}$ : Design value of the applied shear force)			

fischer injection system FIS V Plus

**Performances**

Displacements for anchor rods and fischer internal threaded anchors RG MI

**Annex C 10**



**Table C11.1: Displacements for reinforcing bars**

Nominal diameter of the bar $\phi$	8	10	12	14	16	20	25	28	
<b>Displacement-Factors for tension load<sup>1)</sup></b>									
<b>Uncracked concrete; Temperature range I, II</b>									
$\delta_{N0}$ -Factor	[mm/(N/mm <sup>2</sup> )]	0,09	0,09	0,10	0,10	0,10	0,10	0,10	0,11
$\delta_{N\infty}$ -Factor		0,10	0,10	0,12	0,12	0,12	0,12	0,12	0,13
<b>Cracked concrete; Temperature range I, II</b>									
$\delta_{N0}$ -Factor	[mm/(N/mm <sup>2</sup> )]	-. <sup>3)</sup>	0,12	0,13	0,13	0,13	0,13	0,13	0,14
$\delta_{N\infty}$ -Factor		-. <sup>3)</sup>	0,27	0,30	0,30	0,30	0,30	0,30	0,35
<b>Displacement-Factors for shear load<sup>2)</sup></b>									
<b>Uncracked or cracked concrete; Temperature range I, II</b>									
$\delta_{V0}$ -Factor	[mm/kN]	0,11	0,11	0,10	0,10	0,10	0,09	0,09	0,08
$\delta_{V\infty}$ -Factor		0,12	0,12	0,11	0,11	0,11	0,10	0,10	0,09
<sup>1)</sup> Calculation of effective displacement: $\delta_{N0} = \delta_{N0}\text{-Factor} \cdot \tau_{Ed}$ $\delta_{N\infty} = \delta_{N\infty}\text{-Factor} \cdot \tau_{Ed}$ ( $\tau_{Ed}$ : Design value of the applied tensile stress)					<sup>2)</sup> Calculation of effective displacement: $\delta_{V0} = \delta_{V0}\text{-Factor} \cdot V_{Ed}$ $\delta_{V\infty} = \delta_{V\infty}\text{-Factor} \cdot V_{Ed}$ ( $V_{Ed}$ : Design value of the applied shear force)				
<sup>3)</sup> No performance assessed									

**Table C11.2: Displacements for fischer rebar anchors FRA**

fischer rebar anchor FRA	M12	M16	M20	M24	
<b>Displacement-Factors for tension load<sup>1)</sup></b>					
<b>Uncracked concrete; Temperature range I, II</b>					
$\delta_{N0}$ -Factor	[mm/(N/mm <sup>2</sup> )]	0,10	0,10	0,10	0,10
$\delta_{N\infty}$ -Factor		0,12	0,12	0,12	0,13
<b>Cracked concrete; Temperature range I, II</b>					
$\delta_{N0}$ -Factor	[mm/(N/mm <sup>2</sup> )]	0,12	0,13	0,13	0,13
$\delta_{N\infty}$ -Factor		0,30	0,30	0,30	0,35
<b>Displacement-Factors for shear load<sup>2)</sup></b>					
<b>Uncracked or cracked concrete; Temperature range I, II</b>					
$\delta_{V0}$ -Factor	[mm/kN]	0,10	0,10	0,09	0,09
$\delta_{V\infty}$ -Factor		0,11	0,11	0,10	0,10
<sup>1)</sup> Calculation of effective displacement: $\delta_{N0} = \delta_{N0}\text{-Factor} \cdot \tau_{Ed}$ $\delta_{N\infty} = \delta_{N\infty}\text{-Factor} \cdot \tau_{Ed}$ ( $\tau_{Ed}$ : Design value of the applied tensile stress)			<sup>2)</sup> Calculation of effective displacement: $\delta_{V0} = \delta_{V0}\text{-Factor} \cdot V_{Ed}$ $\delta_{V\infty} = \delta_{V\infty}\text{-Factor} \cdot V_{Ed}$ ( $V_{Ed}$ : Design value of the applied shear force)		

fischer injection system FIS V Plus

**Performances**  
 Displacements for reinforcing bars and fischer rebar anchors FRA

**Annex C 11**

Appendix 31 / 35

**Table C12.1: Characteristic values for steel failure under tension / shear load of fischer anchor rods and standard threaded rods under seismic action performance category C1 or C2**

Anchor rod / standard threaded rod		M10	M12	M16	M20	M24	M27	M30			
<b>Bearing capacity under tension load, steel failure<sup>1)</sup></b>											
<b>fischer anchor rods and standard threaded rods, performance category C1<sup>2)</sup></b>											
Characteristic resistance $N_{Rk,s,C1}$	Steel zinc plated	Property class	5.8	[kN]	29(27)	43	79	123	177	230	281
			8.8		47(43)	68	126	196	282	368	449
	Stainless steel R and high corrosion resistant steel HCR	50	29		43	79	123	177	230	281	
		70	41		59	110	172	247	322	393	
		80	47		68	126	196	282	368	449	
<b>fischer anchor rods, performance category C2<sup>2)</sup></b>											
Characteristic resistance $N_{Rk,s,C2}$	Steel zinc plated	Property class	5.8	[kN]	-4)	39	72	108	-4)	-4)	-4)
			8.8		-4)	61	116	173	-4)	-4)	-4)
	Stainless steel R and high corrosion resistant steel HCR	50	-4)		39	72	108	-4)	-4)	-4)	
		70	-4)		53	101	152	-4)	-4)	-4)	
		80	-4)		61	116	173	-4)	-4)	-4)	
<b>Bearing capacity under shear load, steel failure without lever arm<sup>1)</sup></b>											
<b>fischer anchor rods, performance category C1<sup>2)</sup></b>											
Characteristic resistance $V_{Rk,s,C1}$	Steel zinc plated	Property class	5.8	[kN]	17(16)	25	47	74	106	138	168
			8.8		23(21)	34	63	98	141	184	225
	Stainless steel R and high corrosion resistant steel HCR	50	15		21	39	61	89	115	141	
		70	20		30	55	86	124	161	197	
		80	23		34	63	98	141	184	225	
<b>Standard threaded rods, performance category C1<sup>2)</sup></b>											
Characteristic resistance $V_{Rk,s,C1}$	Steel zinc plated	Property class	5.8	[kN]	12(11)	17	33	52	74	97	118
			8.8		16(14)	24	44	69	99	129	158
	Stainless steel R and high corrosion resistant steel HCR	50	11		15	27	43	62	81	99	
		70	14		21	39	60	87	113	138	
		80	16		24	44	69	99	129	158	
<b>fischer anchor rods, performance category C2</b>											
Characteristic resistance $V_{Rk,s,C2}$	Steel zinc plated	Property class	5.8	[kN]	-4)	14	27	43	-4)	-4)	-4)
			8.8		-4)	22	44	69	-4)	-4)	-4)
	Stainless steel R and high corrosion resistant steel HCR	50	-4)		14	27	43	-4)	-4)	-4)	
		70	-4)		20	39	60	-4)	-4)	-4)	
		80	-4)		22	44	69	-4)	-4)	-4)	
Factor for the annular gap	$\alpha_{gap}$	[-]	0,5 (1,0) <sup>3)</sup>								

<sup>1)</sup> Partial factors for performance category C1 or C2 see table C13.1; for fischer anchor rods FIS A / RGM the factor for steel ductility is 1,0

<sup>2)</sup> Values in brackets are valid for undersized threaded rods with smaller stress area  $A_s$  and for hot dip galvanised standard threaded rods according to EN ISO 10684:2004+AC:2009.

<sup>3)</sup> Values in brackets are valid for filled annular gaps between the anchor rod and the through-hole in the attachment. It is necessary to use the fischer filling disc according to Annex A 5

<sup>4)</sup> No performance assessed

fischer injection system FIS V Plus

**Performances**

Characteristic values for steel failure under tension / shear load for fischer anchor rods and standard threaded rods under seismic action (performance category C1 / C2)

**Annex C 12**

Appendix 32 / 35

**Table C13.1: Partial factors for fischer anchor rods, standard threaded rods under seismic action performance category C1 or C2**

Anchor rod / standard threaded rod			M10	M12	M16	M20	M24	M27	M30
<b>Tension load, steel failure<sup>1)</sup></b>									
Partial factor $\gamma_{Ms,N}$	Steel zinc plated	Property class	5.8	[-]	1,50				
			8.8		1,50				
	Stainless steel R and high corrosion resistant steel HCR		50		2,86				
			70		1,50 <sup>2)</sup> / 1,87				
			80		1,60				
<b>Shear load, steel failure<sup>1)</sup></b>									
Partial factor $\gamma_{Ms,V}$	Steel zinc plated	Property class	5.8	[-]	1,25				
			8.8		1,25				
	Stainless steel R and high corrosion resistant steel HCR		50		2,38				
			70		1,25 <sup>2)</sup> / 1,56				
			80		1,33				

<sup>1)</sup> In absence of other national regulations

<sup>2)</sup> Only admissible for high corrosion resistant steel HCR, with  $f_{yk} / f_{uk} \geq 0,8$  and  $A_s > 12\%$  (e.g. fischer anchor rods)

fischer injection system FIS V Plus

**Performances**

Partial factors under seismic action (performance category C1 and C2) for fischer anchor rods and standard threaded rods

**Annex C 13**

Appendix 33 / 35

**Table C14.1: Characteristic values for combined pull-out and concrete failure for fischer anchor rods and standard threaded rods in hammer drilled holes under seismic action performance category C1, working life 50 and 100 years**

Anchor rod / standard threaded rod		M10	M12	M16	M20	M24	M27	M30	
<b>Characteristic bond resistance, combined pullout and concrete cone failure</b>									
<b>Hammer-drilling with standard drill bit or hollow drill bit (dry or wet concrete)</b>									
Temperature range	I: 50 °C / 80 °C	$\tau_{Rk,C1}$ [N/mm <sup>2</sup> ]	4,5	5,5	5,5	5,5	4,5	4,0	4,0
	II: 72 °C / 120 °C		4,0	4,5	4,5	4,5	4,0	3,5	3,5
<b>Hammer-drilling with standard drill bit or hollow drill bit (water filled hole)</b>									
Temperature range	I: 50 °C / 80 °C	$\tau_{Rk,C1}$ [N/mm <sup>2</sup> ]	- <sup>1)</sup>	5,0	5,0	4,5	4,0	3,5	3,5
	II: 72 °C / 120 °C		- <sup>1)</sup>	4,0	4,0	4,0	3,5	3,0	3,0
<b>Installation factors</b>									
Dry or wet concrete	$\gamma_{inst}$	[-]	1,0						
Water filled hole			- <sup>1)</sup>	1,2					

<sup>1)</sup> No performance assessed

fischer injection system FIS V Plus

**Performances**

Characteristic values under seismic action (performance category C1) for fischer anchor rods and standard threaded rods, working life 50 and 100 years

**Annex C 14**

Appendix 34 / 35

**Table C15.1: Characteristic values for combined pull-out and concrete failure for fischer anchor rods in hammer drilled holes under seismic action performance category C2; working life 50 and 100 years**

Anchor rod / standard threaded rod		M12	M16	M20	
<b>Characteristic bond resistance, combined pullout and concrete cone failure</b>					
<b>Hammer-drilling with standard drill bit or hollow drill bit (dry or wet concrete)</b>					
Tem- perature range	I: 50 °C / 80 °C	$\tau_{Rk,C2}$ [N/mm <sup>2</sup> ]	1,5	1,3	2,1
	II: 72 °C / 120 °C		1,3	1,2	1,9
<b>Hammer-drilling with standard drill bit or hollow drill bit (water filled hole)</b>					
Tem- perature range	I: 50 °C / 80 °C	$\tau_{Rk,C2}$ [N/mm <sup>2</sup> ]	1,3	1,1	1,8
	II: 72 °C / 120 °C		1,1	1,0	1,6
<b>Displacement-Factors for tension load<sup>1)</sup></b>					
$\delta_{N,C2}$ (DLS)-Factor	[mm/(N/mm <sup>2</sup> )]	0,20	0,13	0,21	
$\delta_{N,C2}$ (ULS)-Factor		0,38	0,18	0,24	
<b>Displacement-Factors for shear load<sup>2)</sup></b>					
$\delta_{V,C2}$ (DLS)-Factor	[mm/kN]	0,18	0,10	0,07	
$\delta_{V,C2}$ (ULS)-Factor		0,25	0,14	0,11	
<sup>1)</sup> Calculation of effective displacement: $\delta_{N,C2}$ (DLS) = $\delta_{N,C2}$ (DLS)-Factor · $\tau_{Ed}$ $\delta_{N,C2}$ (ULS) = $\delta_{N,C2}$ (ULS)-Factor · $\tau_{Ed}$ ( $\tau_{Ed}$ : Design value of the applied tensile stress)		<sup>2)</sup> Calculation of effective displacement: $\delta_{V,C2}$ (DLS) = $\delta_{V,C2}$ (DLS)-Factor · $V_{Ed}$ $\delta_{V,C2}$ (ULS) = $\delta_{V,C2}$ (ULS)-Factor · $V_{Ed}$ ( $V_{Ed}$ : Design value of the applied shear force)			
<sup>3)</sup> No performance assessed					

fischer injection system FIS V Plus

**Performances**

Characteristic values under seismic action (performance category C2) for fischer anchor rods; working life 50 and 100 years

**Annex C 15**

Appendix 35 / 35