

The Drawing and its contents are to be kept secret from third parties, particularly competitors. The drawing and documents which go with it are not to be duplicated either in local or extract, or used in other documentation without express approval (§15 and §18 UrHG - §1 and §18 UWG). A reservation of rights in accordance with §12 PatG is declared for the event that a patent is granted.

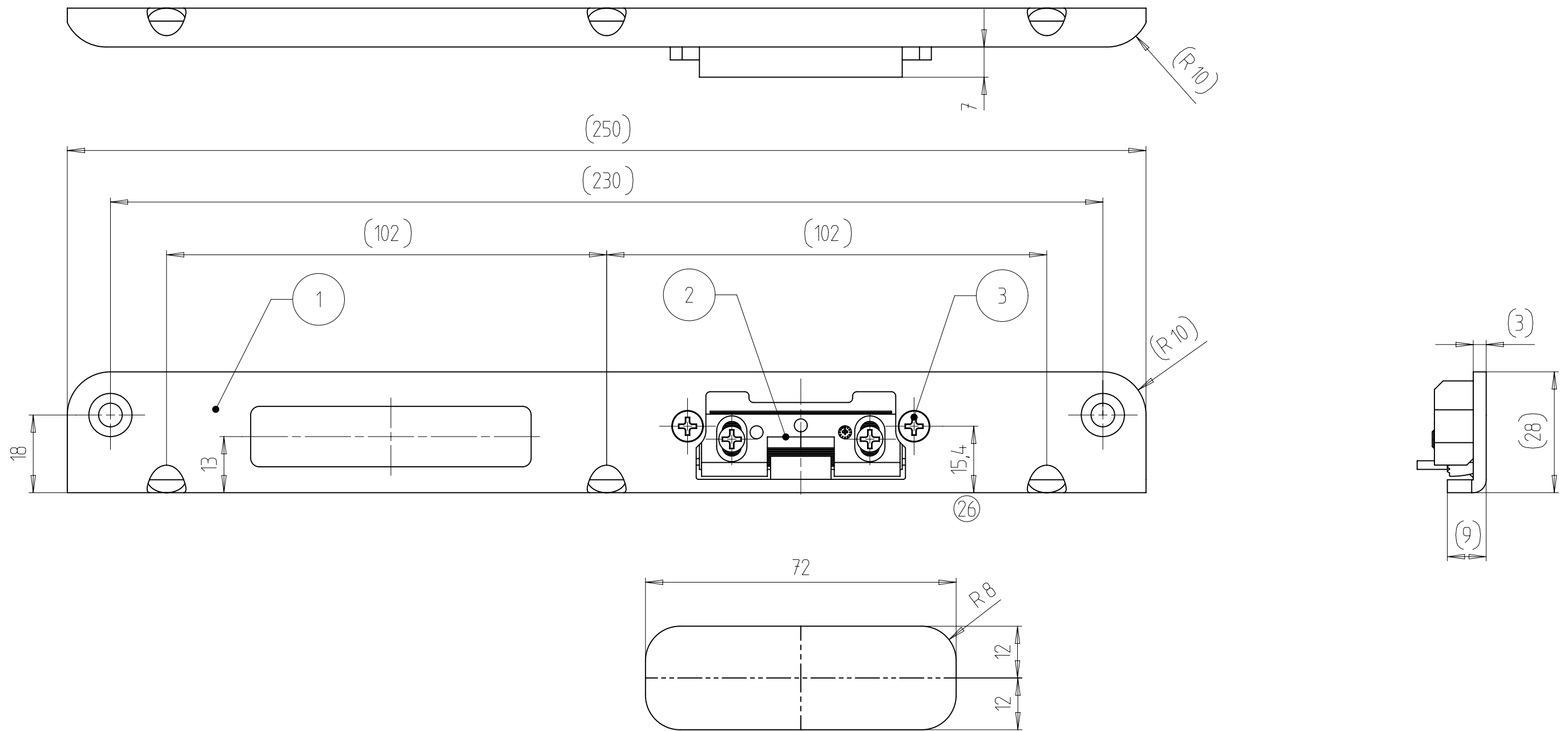

nur mit abgesetzter Falle einsetzbar

Frästiefe = angegebene Tiefe + min. 1 mm

Fräser \varnothing 16 mm
Anlaufring \varnothing 27 mm

wie gezeichnet DIN links
spiegelbildlich DIN rechts

Tolerierung nach ISO 8015

Pos. 1 und Pos. 2 mit Pos. 3 verschraubt

Pos	Benennung	Stck	PDM-Nr.	Bemerk
3	Senkschraube DIN 965-M4x6	2	9.999.03370	
2	AT-Stueck kplt.	1	7.803.00038	
1	Winkel- Schliessblech	1	9.851.00051	

Qty. 1	Type of Modification	Anpassung an die Fertigung		ANT	Drawn M. M.-Bachem	Approved P. Thode	Date 08.04.2016	
Volume /mm ³	Weight/g	Material-No.	Item-No.		Tool-No.			
25904	199,782		17-580-1ER					
		Tolerance ISO 2768 mK	Part-Discription Winkel- Schliessblech					
Scale 1 : 1		Additional Notice						
Drawn Hoeltgen		KFV		Document No. 7.851.00046		Doc. Part No. 000	Revision 26	Status 20
Date 06.08.1999	Replacement for :			Test procedure		Size A3		
Appr. Wiesner	Replaced by :							
Date 16.08.1999								