

The Drawing and its contents are to be kept secret from third parties, particularly competitors. The drawing and documents which go with it are not to be duplicated either in local or extract, or used in other documentation without express approval (815 and 38 UrHG - §1 and 18 UWG). A reservation of rights in accordance with §12 PatG is declared for the event that a patent is granted.

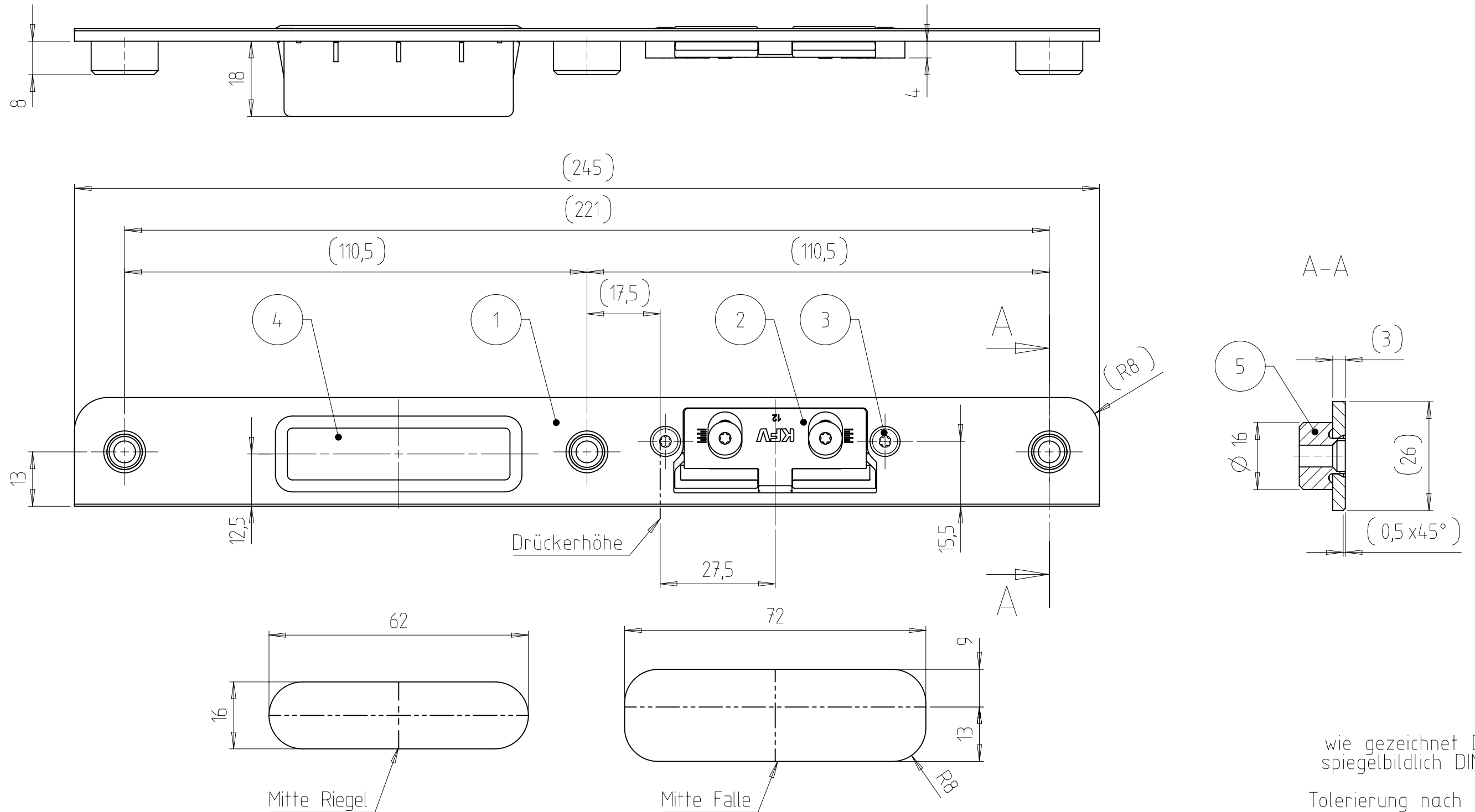

wie gezeichnet DIN links  
spiegelbildlich DIN rechts

Tolerierung nach ISO 8015

Pos. 4 in Pos. 1 geklipst  
Pos. 1 und 2 mit Pos. 3 verschraubt  
Pos. 5 mit Pos. 1 schlagvernietet

Frästiefe = angegebene Tiefe + min. 1mm

Fräser  $\varnothing$  16mm  
Anlauftring  $\varnothing$  27mm

Pos	Benennung	Stck	PDM-Nr.	Teil	Bemerk
5	Distanzstueck	3	9.745.00039	000	
4	Hinterfuetterung	1	9.806.00080	000	
3	Torx - Schraube M4x6	2	9.741.14817	000	
2	AT-Stueck kplt.	1	7.803.16209	000	
1	Flach- Schliessblech	1	9.841.22776	000	

Qty.	Type of Modification	ANT	Drawn	Approved	Date
		Y7252A			
Volume /mm <sup>3</sup>	Weight/g	Material-No.	Item-No.	Tool-No.	
25176	175,050		8050-434E8H		
		Tolerance	Part-Description		
		ISO 2768 mK	Flach- Schliessblech		
Scale	Additional Notice		Document No.	Doc. Part No.	Revision
1 : 1			7.841.22777	000	00
Drawn	M. Müller-Bachem	<b>KFV</b>	Replacement for :		Test procedure
Date	17.10.2017		Replaced by :		
Appr.	P. Thode				A3
Date	18.10.2017				

20

A3