

DICHIARAZIONE DI PRESTAZIONE

DoP 0354

per il Sistema a iniezione fischer FIS V Plus (ancorante chimico per l'utilizzo in muratura)

IT

1. Codice di identificazione unico del prodotto-tipo: **DoP 0354**
2. Usi previsti: **Fissaggio post-installato negli elementi in muratura, Vedi appendice, in particolare gli allegati da B1 - B22.**
3. Fabbricante: **fischerwerke GmbH & Co. KG, Otto-Hahn-Straße 15, 79211 Denzlingen, Germany**
4. Mandatario: **-**
5. Sistemi di VVCP: **1**
6. Documento per la valutazione europea: **EAD 330076-01-0604, Edition 10/2022**
 Valutazione tecnica europea: **ETA-20/0729; 2023-10-31**
 Organismo di valutazione tecnica: **DIBt- Deutsches Institut für Bautechnik**
 Organismi notificati: **2873 TU Darmstadt**
7. Prestazioni dichiarate:
Resistenza meccanica e stabilità (BWR 1)
 Resistenza caratteristica sotto carichi statici o quasi-statici:
 - 1 Resistenza caratteristica per la rottura dell'acciaio di un ancorante singolo sotto azione di trazione: Vedi appendice, in particolare gli allegati da C1, C3
 - 2 Resistenza caratteristica per la rottura dell'acciaio di un ancorante singolo sotto carico di taglio con e senza braccio di leva: Vedi appendice, in particolare gli allegati da C2, C3
 - 3 Resistenza caratteristica per la rottura a sfilamento o per la rottura del mattone di un ancorante singolo sotto carico di trazione, fattore di riduzione: Vedi appendice, in particolare gli allegati da C5, C7, C9, C11, C13, C15, C17, C19, C22, C26, C29, C31, C34, C38, C42, C46, C50, C54, C58, C62, C65, C67, C70, C74, C78, C82, C85, C88, C92, C95, C97, C100, C103, C106, C109, C112, C115, C117, C120, C122, C123
 - 4 Resistenza caratteristica per rottura locale o rottura del bordo del mattone di un ancorante singolo sotto carico di taglio: Vedi appendice, in particolare gli allegati da C5, C7, C9, C11, C13, C15, C17, C19, C23, C27, C29, C31, C35, C39, C43, C47, C51, C55, C59, C63, C65, C68, C71, C75, C79, C83, C85, C89, C93, C95, C97, C101, C103, C107, C109, C113, C115, C117, C120, C122
 - 5 Resistenza caratteristica per rottura del mattone di un gruppo di ancoranti sotto carico di trazione: Vedi appendice, in particolare gli allegati da B21, B22, C4, C6, C8, C10, C12, C14, C16, C18, C20, C21, C24, C25, C28, C30, C32, C33, C36, C37, C40, C41, C44, C45, C48, C49, C52, C53, C56, C57, C60, C61, C64, C66, C69, C72, C73, C76, C77, C80, C81, C84, C86, C87, C90, C91, C94, C96, C98, C99, C102, C104, C105, C108, C110, C111, C114, C116, C119, C121
 - 6 Resistenza caratteristica per rottura locale del mattone o rottura del bordo di un gruppo di ancoranti sotto azione di taglio: Vedi appendice, in particolare gli allegati da B21, B22, C4, C6, C8, C10, C12, C14, C16, C18, C20, C21, C24, C25, C28, C30, C32, C33, C36, C37, C40, C41, C44, C45, C48, C49, C52, C53, C56, C57, C60, C61, C64, C66, C69, C72, C73, C76, C77, C80, C81, C84, C86, C87, C90, C91, C94, C96, C98, C99, C102, C104, C105, C108, C110, C111, C114, C116, C118, C121
 - 7 Distanze dal bordo, interasse, spessore dell'elemento: Vedi appendice, in particolare gli allegati da B21, B22, C4, C6, C8, C10, C12, C14, C16, C18, C20, C21, C24, C25, C28, C30, C32, C33, C36, C37, C40, C41, C44, C45, C48, C49, C52, C53, C56, C57, C60, C61, C64, C66, C69, C72, C73, C76, C77, C80, C81, C84, C86, C87, C90, C91, C94, C96, C98, C99, C102, C104, C105, C108, C110, C111, C114, C116, C118, C121
 - 8 Spostamenti sotto azione di trazione e di taglio: vedi appendice, in particolare gli allegati da C123
 - 9 Coppia di serraggio di installazione massima: Vedi appendice, in particolare gli allegati da B4-B7, B9-B12, C4, C6, C8, C10, C12, C14, C16, C18, C20, C21, C24, C25, C28, C30, C32, C33, C36, C37, C40, C41, C44, C45, C48, C49, C52, C53, C56, C57, C60, C61, C64, C66, C69, C72, C73, C76, C77, C80, C81, C84, C86, C87, C90, C91, C94, C96, C98, C99, C102, C104, C105, C108, C110, C111, C114, C116, C118, C121

Resistenza e spostamenti caratteristici sotto azioni sismiche:

 - 10 Resistenza al carico di trazione, spostamenti: NPD
 - 11 Resistenza al carico di taglio, spostamenti: NPD
 - 12 Fattore spazio anulare: NPD

Sicurezza in caso di incendio (BWR 2)

 - 13 Reazione al fuoco: Classe (A1)
 - 14 Resistenza al fuoco sotto azione di trazione e di taglio con e senza braccio di leva, distanze dal bordo e interassi minimi: vedi appendice, in particolare gli allegati da C124

Igiene, salute e ambiente (BWR 3)

 - 15 Contenuto, emissione e/o rilascio di sostanze pericolose: NPD
8. Documentazione tecnica appropriata e/o documentazione tecnica specifica: **-**

La prestazione del prodotto sopra identificato è conforme all'insieme delle prestazioni dichiarate. La presente dichiarazione di prestazione è emessa, in conformità al regolamento (UE) n. 305/2011, sotto la sola responsabilità del fabbricante sopra identificato.

Firmato a nome e per conto del fabbricante da:



Dr.-Ing. Oliver Geibig, Direttore Generale Unità di Business & Engineering
 Tumlingen, 2023-11-14



Jürgen Grün, Direttore Generale Chimica & Qualità

Questa Dichiarazione di Prestazione (DoP) è stata preparata in varie lingue. In caso di contestazioni sull'interpretazione, prevarrà sempre la versione inglese.

L'Appendice include informazioni volontarie e complementari in lingua inglese che superano i requisiti di legge (lingua specificata in modo neutrale).

Translation guidance Essential Characteristics and Performance Parameters for Annexes

Guida alla traduzione delle Caratteristiche Essenziali e dei Parametri di Prestazione per gli Annessi

Mechanical resistance and stability (BWR 1)		
Resistenza meccanica e stabilità (BWR 1)		
Characteristic resistance for static and quasi-static loading: Resistenza caratteristica sotto carichi statici o quasi-statici:		
1	Characteristic resistance to steel failure of a single anchor under tension loading: Resistenza caratteristica per la rottura dell'acciaio di un ancorante singolo sotto azione di trazione:	$N_{Rk,s}$ [kN]
2	Characteristic resistance to steel failure of a single anchor under shear loading with and without level arm: Resistenza caratteristica per la rottura dell'acciaio di un ancorante singolo sotto carico di taglio con e senza braccio di leva:	$V_{Rk,s}$ [kN], $M^0_{Rk,s}$ [Nm]
3	Characteristic resistance to pull-out failure or brick breakout failure of a single anchor under tension loading, Reduction factor: Resistenza caratteristica per la rottura a sfilamento o per la rottura del mattone di un ancorante singolo sotto carico di trazione, fattore di riduzione:	$N_{Rk,p}$, $N_{Rk,b}$ [kN] $N_{Rk,p,c}$, $N_{Rk,b,c}$ [kN], β [-]
4	Characteristic resistance to local brick failure or brick breakout failure of a single anchor under shear loading: Resistenza caratteristica per rottura locale o rottura del bordo del mattone di un ancorante singolo sotto carico di taglio:	$V_{Rk,b}$, $V_{Rk,c,II}$, $V_{Rk,c,I}$ [kN]
5	Characteristic resistance to brick breakout failure of an anchor group under tension loading: Resistenza caratteristica per rottura del mattone di un gruppo di ancoranti sotto carico di trazione:	N^a_{Rk} [kN], $\alpha_{g,N}$ [-]
6	Characteristic resistance to local brick failure or brick breakout failure of an anchor group under shear loading: Resistenza caratteristica per rottura locale del mattone o rottura del bordo di un gruppo di ancoranti sotto azione di taglio:	$V^a_{Rk,b}$, $V^a_{Rk,c,II}$, $V^a_{Rk,c,I}$ [kN]; $\alpha_{g,V,II}$, $\alpha_{g,V,I}$ [-]
7	Edge distances, spacing, member thickness: Distanze dal bordo, interasse, spessore dell'elemento:	c_{cr} , s_{cr} , c_{min} ; $s_{min,II}$, $s_{min,I}$; h_{min} [mm]
8	Displacements under tension and shear loading: Spostamenti sotto azione di trazione e di taglio:	δ_{N0} , $\delta_{N\infty}$; δ_{V0} , $\delta_{V\infty}$ [mm]
9	Maximum installation torque: Coppia di serraggio di installazione massima:	max. T_{inst} [Nm]
Characteristic resistance and displacements for seismic loading: Resistenza e spostamenti caratteristici sotto azioni sismiche:		
10	Resistance to tension load, displacements: Resistenza al carico di trazione, spostamenti:	$N_{Rk,s,eq}$; $N_{Rk,eq}$ [kN], $\alpha_{N,seis}$ [-]; $\delta_{N,eq}$ [mm]
11	Resistance to shear load, displacements: Resistenza al carico di taglio, spostamenti:	$V_{Rk,s,eq}$; $V_{Rk,b,eq}$ [kN], $\alpha_{V,seis}$ [-]; $\delta_{V,eq}$ [mm]
12	Factor annular gap: Fattore spazio anulare:	α_{gap} [-]
Safety in case of fire (BWR 2)		
Sicurezza in caso di incendio (BWR 2)		
13	Reaction to fire: Reazione al fuoco:	-
14	Resistance to fire under tension and shear loading with and without level arm, minimum edge distances and spacing: Resistenza al fuoco sotto azione di trazione e di taglio con e senza braccio di leva, distanze dal bordo e interassi minimi:	$N_{Rk,s,fi}$; $N_{Rk,p,fi}$ [kN], $N_{Rk,b,fi}$; $V_{Rk,s,fi}$ [kN], $M^0_{Rk,s}$ [Nm], $c_{cr,fi}$, $s_{cr,fi}$ [mm]
Hygiene, health and the environment (BWR 3)		
Igiene, salute e ambiente (BWR 3)		
15	Content, emission and/or release of dangerous substances: Contenuto, emissione e/o rilascio di sostanze pericolose:	-

Specific Part

1 Technical description of the product

The fischer injection system FIS V Plus for masonry is a bonded anchor (injection type) consisting of a mortar cartridge with injection mortar fischer FIS V Plus, FIS VS Plus Low Speed and FIS VW Plus High Speed, a perforated sieve sleeve and an anchor rod with hexagon nut and washer or an internal threaded rod in the range of M6 to M16. The steel elements are made of zinc coated steel, stainless steel or high corrosion resistant steel.

The anchor rod is placed into a drilled hole filled with injection mortar and is anchored via the bond between steel element, injection mortar and masonry and mechanical interlock.

The product description is given in Annex A.

2 Specification of the intended use in accordance with the applicable European Assessment Document

The performances given in Section 3 are only valid if the fastener is used in compliance with the specifications and conditions given in Annex B.

The verifications and assessment methods on which this European Technical Assessment is based lead to the assumption of a working life of the fastener of at least 50 years. The indications given on the working life cannot be interpreted as a guarantee given by the producer, but are to be regarded only as a means for choosing the right products in relation to the expected economically reasonable working life of the works.

3 Performance of the product and references to the methods used for its assessment

3.1 Mechanical resistance and stability (BWR 1)

Essential characteristic	Performance
Characteristic resistance for static and quasi-static loading	See Annexes B 4 to B 7, B 21, B 22, C 1 to C 123
Characteristic resistance and displacements for seismic loading	No performance assessed

3.2 Safety in case of fire (BWR 2)

Essential characteristic	Performance
Reaction to fire	Class A1
Resistance to fire under tension and shear loading with and without lever arm. Minimum edge distances and spacing	See Annex C 124

3.3 Hygiene, health and the environment (BWR 3)

Essential characteristic	Performance
Content, emission and/or release of dangerous substances	No performance assessed

4 Assessment and verification of constancy of performance (AVCP) system applied, with reference to its legal base

In accordance with the European Assessment Document EAD 330076-01-0604 the applicable European legal act is: [97/177/EC].

The system to be applied is: 1

Installation conditions part 1

Anchor rods with perforated sleeve FIS H K; Installation in perforated and solid brick masonry

Pre-positioned anchorage:

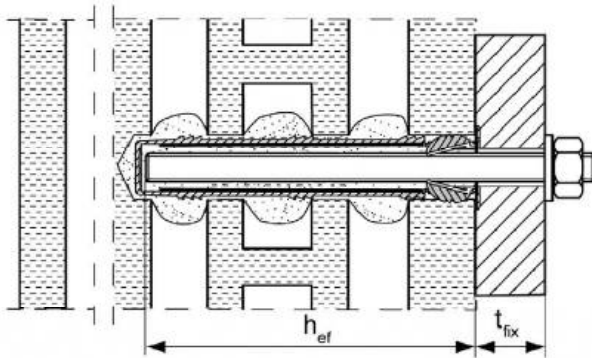

Installation with render bridge

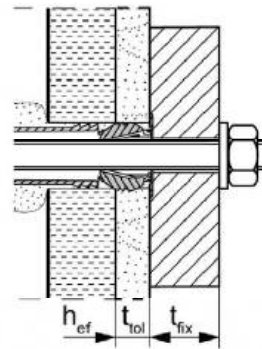

Size of the perforated sleeve: FIS H 12x50 K FIS H 16x85 K FIS H 20x85 K FIS H 20x200 K
 FIS H 12x85 K FIS H 16x130 K FIS H 20x130 K

Push through anchorage:

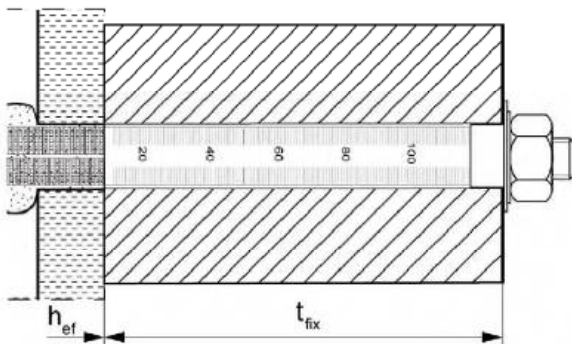

Installation with render bridge

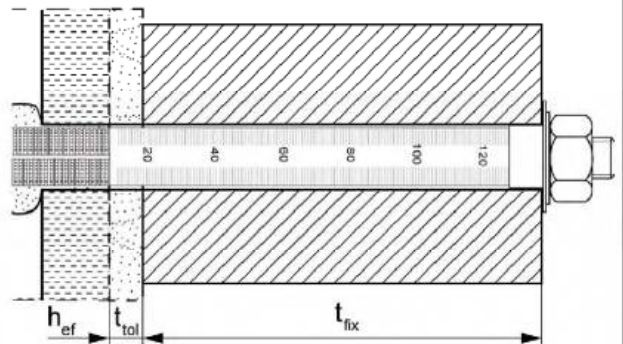

Size of the perforated sleeve: FIS H 18x130/200 K FIS H 22x130/200 K

Internal threaded anchor FIS E with perforated sleeve FIS H K; Installation in perforated and solid brick masonry

Pre-positioned anchorage:

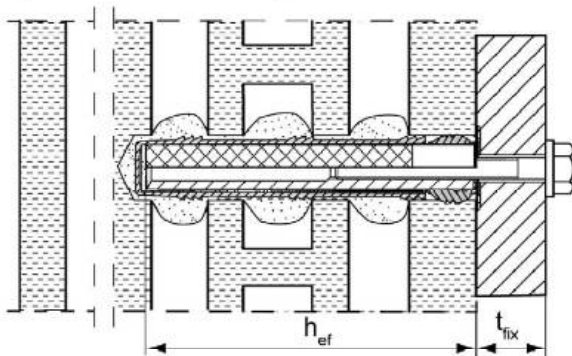

Figures not to scale

h_{ef} = effective anchorage depth

t_{tol} = thickness of unbearing layer (e.g. plaster)

t_{fix} = thickness of fixture

fischer injection system FIS V Plus for masonry

Product description
 Installation conditions part 1,
 Anchor rods and internal threaded anchor with perforated sleeve

Annex A 1

Appendix 3 / 153

Installation conditions part 2

**Anchor rods without perforated sleeve FIS H K;
installation in solid brick masonry and autoclaved aerated concrete**

Pre-positioned anchorage:

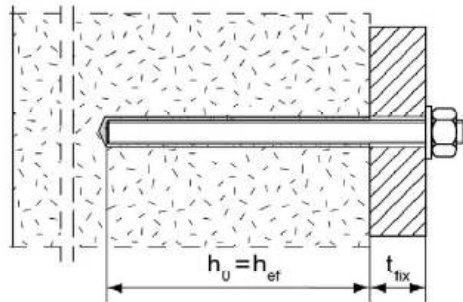

Push through anchorage: Annular gap filled with mortar

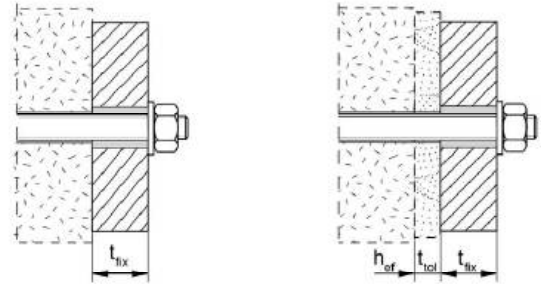

Installation with
render bridge

**Internal threaded anchors FIS E without perforated sleeve FIS H K;
installation in solid brick masonry and autoclaved aerated concrete**

Pre-positioned anchorage:

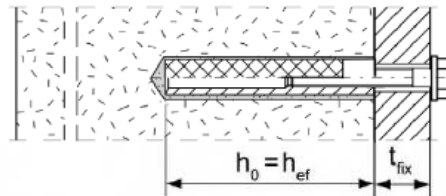

Installation with render bridge

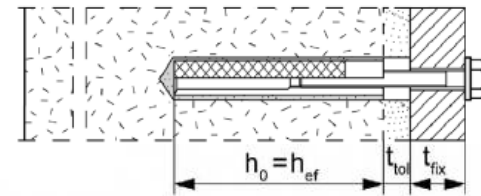

**Anchor rods and internal threaded anchors FIS E without perforated sleeve FIS H K; installation with
centring sleeve in autoclaved aerated concrete with conical drill hole
(installation with special conic drill bit PBB)**

Pre-positioned anchorage:

anchor rods M8, M10, M12

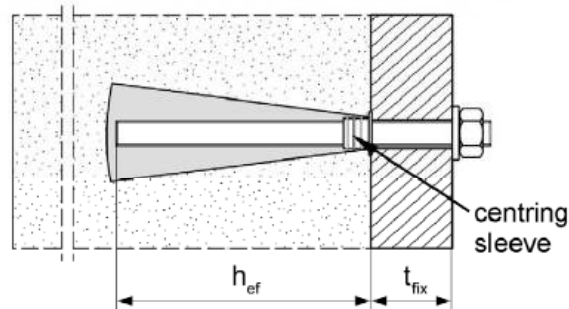

Pre-positioned anchorage:

Internal threaded anchor FIS E 11x85 M6 / M8

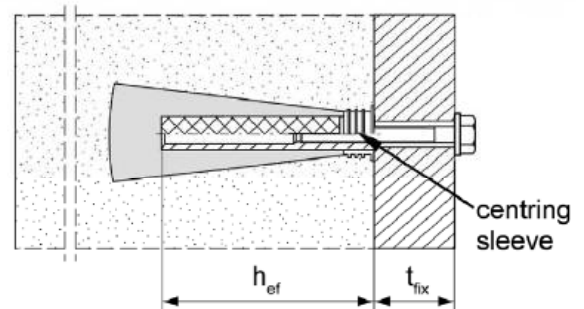

Figures not to scale

h_0 = depth of drill hole

h_{ef} = effective anchorage depth

t_{tol} = thickness of unbearing layer (e.g. plaster)

t_{fix} = thickness of fixture

fischer injection system FIS V Plus for masonry

Product description

Installation conditions part 2, Anchor rods and internal threaded anchor without perforated sleeve / with centring sleeve

Annex A 2

Appendix 4 / 153

Overview system components part 1

Mortar cartridge (shuttle cartridge) with sealing cap

①

Size: 360 ml, 825 ml

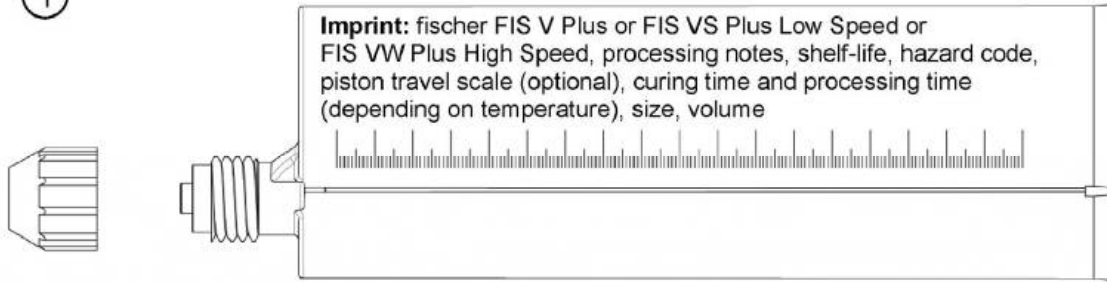

Mortar cartridge (coaxial cartridge) with sealing cap

①

Size: 100 ml, 150 ml, 300 ml, 380 ml, 400 ml, 410 ml

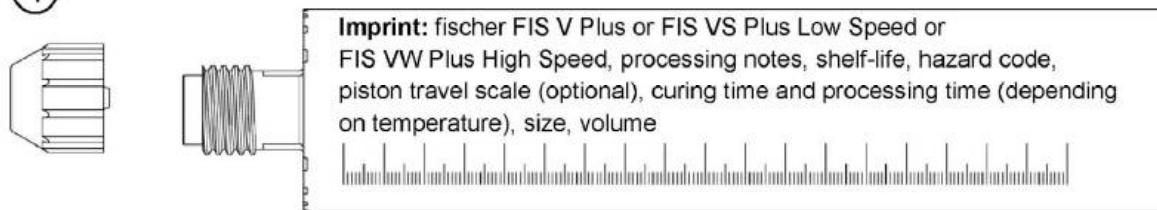

Static mixer FIS MR Plus for injection cartridges up to 410 ml

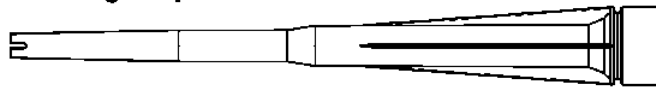

Static mixer FIS JMR for injection cartridges 825 ml



Extension tube Ø 9 for static mixer FIS MR Plus; Extension tube Ø 9 or Ø 15 for static mixer FIS JMR



Cleaning brush BS



Blow-out pump AB-G



compressed-air cleaning tool



Figures not to scale

fischer injection system FIS V Plus for masonry

Product description

Overview system components part 1: cartridge / static mixer / cleaning tools

Annex A 3

Appendix 5 / 153

Overview system components part 2

fischer anchor rod

②



Size: M6, M8, M10, M12, M16

Internal threaded anchor FIS E

⑤



Size: 11x85 M6 / M8
15x85 M10 / M12

Perforated sleeve FIS H K

⑦



Size: FIS H 12x50 K
FIS H 12x85 K
FIS H 16x85 K
FIS H 20x85 K

⑦



Size: FIS H 16x130 K
FIS H 20x130 K
FIS H 20x200 K

Perforated sleeve FIS H K (push through anchorage)

⑦

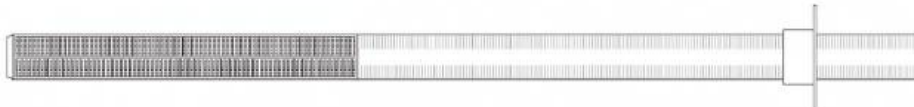

Size: FIS H 18x130/200 K
FIS H 22x130/200 K

Washer

③

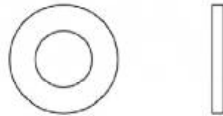

Hexagon nut

④



Injection adapter

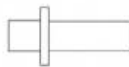

centring sleeve PBZ

⑦



Special conic drill bit PBB

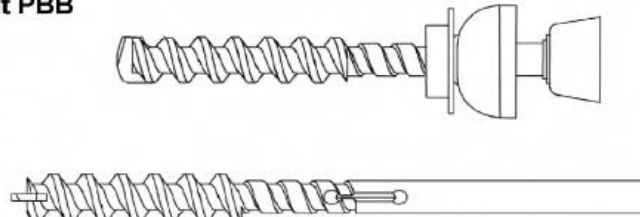

Figures not to scale

fischer injection system FIS V Plus for masonry

Product description

Overview system components part 2: steel parts / perforated sleeve / conical drill bit / Injection adapter / centring sleeve

Annex A 4

Appendix 6 / 153

Table A5.1: Materials

Part	Designation	Material		
1	Mortar cartridge	Mortar, hardener, filler		
		Steel	Stainless steel R	High corrosion resistant steel HCR
		zinc plated	acc. to EN 10088-1:2014 Corrosion resistance class CRC III acc. to EN 1993-1-4:2006+A1:2015	acc. to EN 10088-1:2014 Corrosion resistance class CRC V acc. to EN 1993-1-4:2006+A1:2015
2	Anchor rod	Property class 4.6; 4.8; 5.8 or 8.8; EN ISO 898-1: 2013 zinc plated $\geq 5\mu\text{m}$, ISO 4042:2022 or hot-dip galvanised EN ISO 10684:2004+AC:2009 $f_{uk} \leq 1000 \text{ N/mm}^2$ $A_5 > 8\%$ fracture elongation	Property class 50, 70 or 80 EN ISO 3506-1:2020 1.4401; 1.4404; 1.4578; 1.4571; 1.4439; 1.4362; 1.4062; 1.4662; 1.4462; EN 10088-1:2014 $f_{uk} \leq 1000 \text{ N/mm}^2$ $A_5 > 8\%$ fracture elongation	Property class 50 or 80 EN ISO 3506-1:2020 or property class 70 with $f_{yk} = 560 \text{ N/mm}^2$ 1.4565; 1.4529 EN 10088-1:2014 $f_{uk} \leq 1000 \text{ N/mm}^2$ $A_5 > 8\%$ fracture elongation
3	Washer ISO 7089:2000	zinc plated $\geq 5\mu\text{m}$, ISO 4042:2018 or hot-dip galvanised EN ISO 10684:2004+AC:2009	1.4401; 1.4404; 1.4578; 1.4571; 1.4439; 1.4362; EN 10088-1:2014	1.4565; 1.4529 EN 10088-1:2014
4	Hexagon nut	Property class 5 or 8; EN ISO 898-2:2012 zinc plated $\geq 5\mu\text{m}$, ISO 4042:2018 or hot-dip galvanised EN ISO 10684:2004+AC:2009	Property class 50, 70 or 80 EN ISO 3506-2:2020 1.4401; 1.4404; 1.4578; 1.4571; 1.4439; 1.4362; EN 10088-1:2014	Property class 50, 70 or 80 EN ISO 3506-2:2020 1.4565; 1.4529 EN 10088-1:2014
5	Internal threaded anchor FIS E	Property class 5.8; EN 10277-1:2008-06 zinc plated $\geq 5\mu\text{m}$, ISO 4042:2018	Property class 70 EN ISO 3506-1:2020 1.4401; 1.4404; 1.4578; 1.4571; 1.4439; 1.4362; EN 10088-1:2014	Property class 70 EN ISO 3506-1:2020 1.4565; 1.4529 EN 10088-1:2014
6	Commercial standard screw or threaded rod for internal threaded anchor FIS E	Property class 4.6, 5.8 or 8.8; EN ISO 898-1:2013 zinc plated $\geq 5\mu\text{m}$, ISO 4042:2018	Property class 70 EN ISO 3506-1:2020 1.4401; 1.4404; 1.4578; 1.4571; 1.4439; 1.4362; EN 10088-1:2014	Property class 70 EN ISO 3506-1:2020 1.4565; 1.4529 EN 10088-1:2014
7	Perforated sleeve and centring sleeve	PP / PE		



fischer injection system FIS V Plus for masonry

Product description
 Materials
Annex A 5

Appendix 7 / 153

Specifications of intended use part 1

Table B1.1: Overview use and performance categories

Anchorages subject to		fischer injection system FIS V Plus for masonry	
Hole drilling with hammer drill mode 		all bricks; without C 28 to C 48, C 75 to C 78	
Hole drilling with rotary drill mode 		all bricks	
Hole drilling with special conic drill bit		Only C 118 to C 122	
Static and quasi static load, in masonry		all bricks	
Resistance to fire under tension and shear loading		C 124 (Applies only to the conditions of dry masonry)	
Installation	Pre-positioned anchorage	Anchor rod or internal threaded anchor (in solid brick masonry and autoclaved aerated concrete)	Perforated sleeve with anchor rod or internal threaded anchor (in perforated and solid brick masonry) Size: FIS H 12x50 K FIS H 12x85 K FIS H 16x85 K FIS H 16x130 K FIS H 20x85 K FIS H 20x130 K FIS H 20x200 K
	Push through anchorage	Anchor rod; use only in cylindrical drill hole (in solid brick masonry and autoclaved aerated concrete)	Perforated sleeve with anchor rod (in perforated and solid brick masonry) Size: FIS H 18x130/200 K FIS H 22x130/200 K
Installation and use conditions	conditions d/d (dry/dry)	all bricks	
	conditions w/d (wet/dry)		
	conditions w/w (wet/wet)		
Installation direction	D3 (downward and horizontal installation)		
Installation temperature	$T_{i,min} = -10\text{ °C}$ to $T_{i,max} = +40\text{ °C}$		
In-service temperature	Temperature range Tb	-40 °C to +80 °C	(max. short term temperature +80 °C max. long term temperature +50 °C)
	Temperature range Tc	-40 °C to +120 °C	(max. short term temperature +120 °C; max. long term temperature +72 °C)

fischer injection system FIS V Plus for masonry

Intended Use
Specifications part 1

Annex B 1

Appendix 8 / 153

Specifications of intended use part 2

Anchorage subject to:

- Static and quasi-static loads
- Resistance to fire under tension and shear loading

Base materials:

- Solid brick masonry (base material group b) and autoclaved aerated concrete (base material group d), acc. to Annex B 13 / B 14.
- Hollow brick masonry (base material group c), according to Annex B 13 / B 14
- For minimum thickness of masonry member is $h_{ef}+30\text{mm}$
- Mortar strength class of the masonry M2,5 at minimum according to EN 998-2:2016
- For other bricks in solid masonry, hollow or perforated masonry and autoclaved aerated concrete, the characteristic resistance of the anchor may be determined by job site tests (not for bricks under fire exposure) according to EOTA Technical Report TR 053:2022-07, Annex B under consideration of the β -factor according to Annex C 123, Table C123.1.

Note (only applies to solid bricks and autoclaved aerated concrete):

The characteristic resistance is also valid for larger brick sizes, higher compressive strength and higher raw density of the masonry unit.

Temperature Range:

- **Tb:** From - 40°C to +80°C (max. short term temperature +80°C and max. long term temperature +50°C)
- **Tc:** From -40°C to +120°C (max. short term temperature +120°C and max. long term temperature +72°C)

Use conditions (Environmental conditions):

- Structures subject to dry internal conditions (zinc plated steel, stainless steel or high corrosion resistant steel)
- For all other conditions according to EN 1993-1-4:2015 corresponding to corrosion resistance classes to Annex A 5, Table A5.1.

fischer injection system FIS V Plus for masonry

Intended Use
Specifications part 2

Annex B 2

Appendix 9 / 153

Specifications of intended use part 2 continued

Design:

- The anchorages have to be designed in accordance with EOTA Technical Report TR 054:2022-07 (included the dimensioning for fire exposure), Design method A under the responsibility of an engineer experienced in anchorages and masonry work.

Applies to all bricks, if no other values are specified:

$$N_{Rk} = N_{Rk,b} = N_{Rk,p} = N_{Rk,b,c} = N_{Rk,p,c}$$

$$V_{Rk} = V_{Rk,b} = V_{Rk,c,II} = V_{Rk,c,\perp}$$

For the calculation of pulling out a brick under tension loading $N_{Rk,pb}$ or pushing out a brick under shear loading $V_{Rk,pb}$ see EOTA Technical Report TR 054:2022-07.

$N_{Rk,s}$, $V_{Rk,s}$ and $M^0_{Rk,s}$ see annexes C 1-C 3

Factors for job site tests and displacements see annex C 123.

- Verifiable calculation notes and drawings have to be prepared taking account the relevant masonry in the region of the anchorage, the loads to be transmitted and their transmission to the supports of the structure. The position of the anchor is indicated on the design drawings.

Installation:

- Conditions d/d: - Installation and use in dry structures.
- Conditions w/w: - Installation and use in dry and wet structures.
- Conditions w/d: - Installation in wet structures and use in dry structures.
- Hole drilling see Annex C (drilling method).
- In case of aborted hole: The hole shall be filled with mortar.
- Bridging of unbearing layer (e.g., plaster) masonry with solid bricks and cylindrical drill hole. At perforated brick masonry see Annex B 6, Table B6.1.
- Anchor installation carried out by appropriately qualified personnel and under the supervision of the person responsible for technical matters of the site.
- Fastening screws or anchor rods (including nut and washer) must comply with the appropriate material and property class of the fischer internal threaded anchor FIS E.
- Minimum curing time see Annex B 8, Table B8.2.
- Commercial standard threaded rods, washers and hexagon nuts may also be used if the following requirements are fulfilled:

Material dimensions and mechanical properties of the metal parts according to the specifications are given in Annex A 5, Table A5.1

Conformation of material and mechanical properties of the metal parts by inspection certificate 3.1 according to EN 10204:2004, the documents shall be stored.

Marking of the anchor rod with the envisage embedment depth. This may be done by the manufacturer of the rod or by a person on job site.

fischer injection system FIS V Plus for masonry

Intended Use
Specifications part 2 continued

Annex B 3

Appendix 10 / 153

Table B4.1: Installation parameters for anchor rods in solid bricks and autoclaved aerated concrete without perforated sleeves

Anchor rod	Thread	M6	M8	M10	M12	M16
Nominal drill hole diameter	d_0 [mm]	8	10	12	14	18
Effective anchorage depth $h_{ef}^{1)}$ in AAC cylindrical drill hole	$h_{0,min}=h_{ef,min}$ [mm]	100				
	$h_{0,max}=h_{ef,max}$ [mm]	200				
Effective anchorage depth $h_{ef}^{1)}$ in AAC conical drill hole	h_0 [mm]	$h_{ef} + 5$				
	$h_{ef,1}$ [mm]	-	75			-
	$h_{ef,2}$ [mm]	95				
Effective anchorage depth $h_{ef}^{1)}$ in solid brick (depth of drill hole $h_0 = h_{ef}$)	$h_{ef,min}$ [mm]	50				
	$h_{ef,max}$ [mm]	$h-30, \leq 200$				
Diameter of clearance hole in the fixture	pre-position $d_r \leq$ [mm]	7	9	12	14	18
	push through $d_r \leq$ [mm]	9	11	14	16	20
Diameter of cleaning brush	$d_b \geq$ [mm]	see Table B8.1				
Maximum installation torque	T_{inst} [Nm]	see parameters of brick				

¹⁾ $h_{ef,min} \leq h_{ef} \leq h_{ef,max}$ is possible.

fischer anchor rods M6, M8, M10, M12, M16

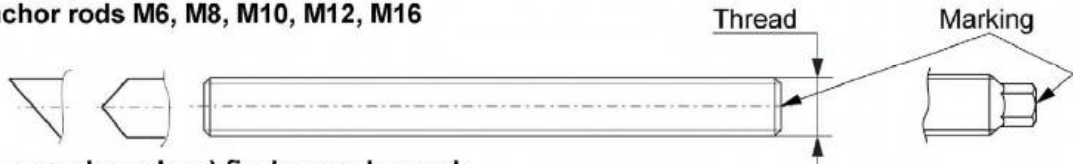

Marking (on random place) fischer anchor rod:

Steel zinc plated PC ¹⁾ 8.8	• or +	Steel hot-dip galvanised PC ¹⁾ 8.8	•
High corrosion resistant steel HCR PC ¹⁾ 50	•	High corrosion resistant steel HCR PC ¹⁾ 70	-
High corrosion resistant steel HCR PC ¹⁾ 80	(Stainless steel R property class 50	~
Stainless steel R property class 80	*		

Alternatively: Colour coding according to DIN 976-1: 2016; property class 4.6 marking according to EN ISO 898-1:2013

¹⁾ PC = property class

Installation conditions:

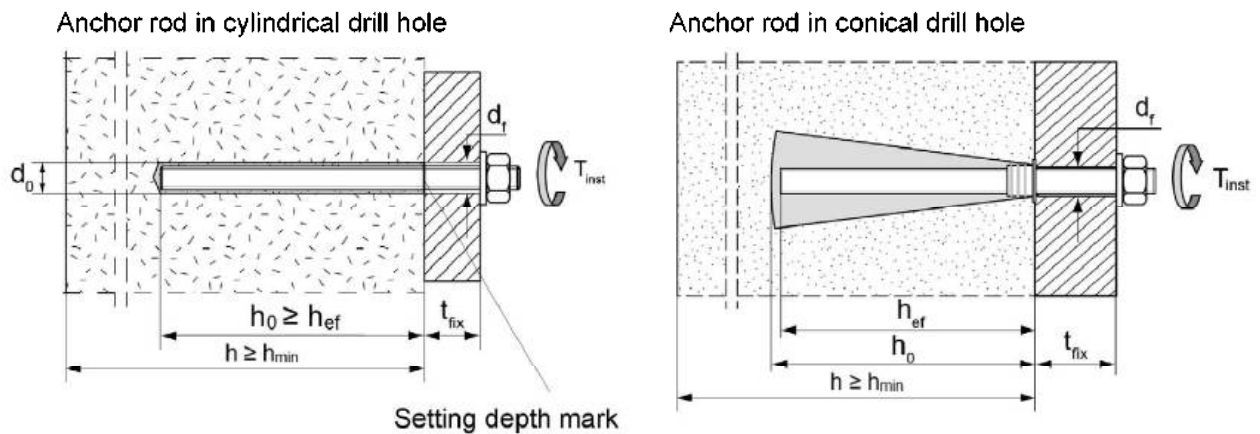

Figures not to scale

fischer injection system FIS V Plus for masonry

Intended Use
Installation parameters for anchor rods without perforated sleeve

Annex B 4

Appendix 11 / 153

Table B5.1: Installation parameters for internal threaded anchors FIS E in solid bricks and autoclaved aerated concrete without perforated sleeves

Internal threaded anchor FIS E		11x85 M6	11x85 M8	15x85 M10	15x85 M12
Diameter of anchor	d_H [mm]	11		15	
Nominal drill hole diameter	d_0 [mm]	14		18	
Length of anchor	L_H [mm]	85			
Effective anchorage depth	$h_0 = h_{ef}$ [mm]	85			
Effective anchorage depth h_{ef} in AAC (conical drill hole)	h_0 [mm]	100		-	
	h_{ef} [mm]	85			
Diameter of cleaning brush	$d_b \geq$ [mm]	see Table B8.1			
Maximum installation torque	T_{inst} [Nm]	see parameters of brick			
Diameter of clearance hole in the fixture	d_f [mm]	7	9	12	14
	$l_{E,min}$ [mm]	6	8	10	12
Screw-in depth	$l_{E,max}$ [mm]	60			

fischer Internal threaded anchor FIS E

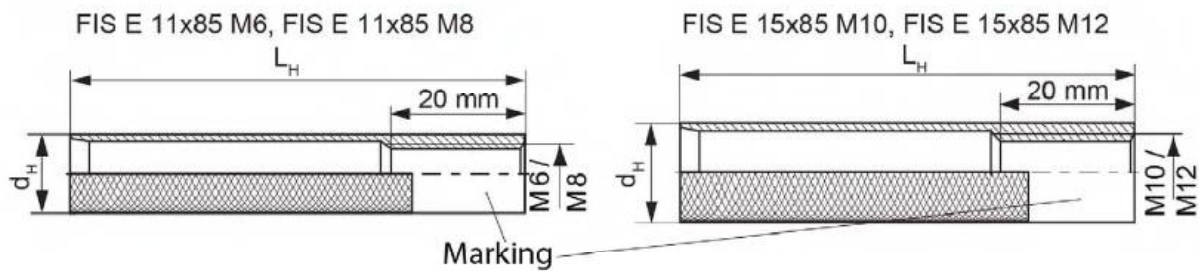

Marking:

Size, e.g. **M8**, Stainless steel: R, e.g. **M8 R**, High corrosion resistant steel: HCR, e.g. **M8 HCR**

Installation conditions:

Internal threaded anchor in cylindrical drill hole

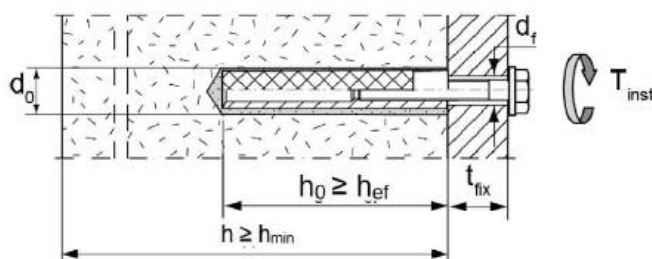

Internal threaded anchor in conical drill hole

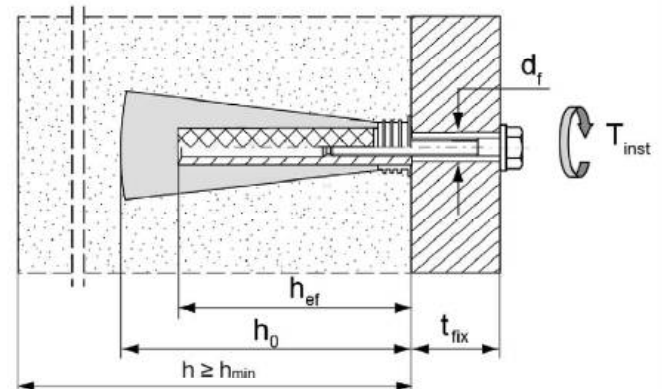

Figures not to scale

fischer injection system FIS V Plus for masonry

Intended Use

Installation parameters for internal threaded rods FIS E without perforated sleeve

Annex B 5

Appendix 12 / 153

Table B6.1: Installation parameters for anchor rods and internal threaded anchors FIS E with perforated sleeves (pre-positioned anchorage)

perforated sleeve FIS H K		12x50	12x85 ²⁾	16x85	16x130 ²⁾	20x85	20x130 ²⁾	20x200 ²⁾
Nominal drill hole diameter $d_0 = D_{\text{sleeve, nom}}$	d_0 [mm]	12		16		20		
Depth of drill hole	h_0 [mm]	55	90	90	135	90	135	205
Effective anchorage depth	$h_{\text{ef, min}}$ [mm]	50	65	85	110	85	110	180
	$h_{\text{ef, max}}$ [mm]	50	85	85	130	85	130	200
Size of threaded rod	[-]	M6 and M8		M8 and M10		M12 and M16		
Size of internal threaded anchor FIS E		-	-	11x85	-	15x85	-	-
Diameter of cleaning brush ¹⁾	$d_b \geq$ [mm]	see Table B8.1						
Maximum installation torque	T_{inst} [Nm]	see parameters of brick						

¹⁾ Only for solid areas in hollow bricks and solid bricks.

²⁾ Bridging of unbearing layer (e.g. plaster) is possible. When reducing the effective anchorage depth $h_{\text{ef, min}}$, the values of the next shorter perforated sleeve of the same diameter must be used. The smaller value of characteristic resistance must be taken.

Perforated sleeve

FIS H 12x50 K; FIS H 12x85 K; FIS H 16x85 K; FIS H 16x130 K;
FIS H 20x85 K; FIS H 20x130 K; FIS H 20x200 K

Marking:

Size $D_{\text{sleeve, nom}} \times L_{\text{sleeve}}$
(e.g.: 16x85)

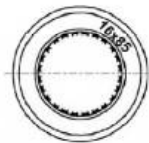

$D_{\text{sleeve, nom}}$

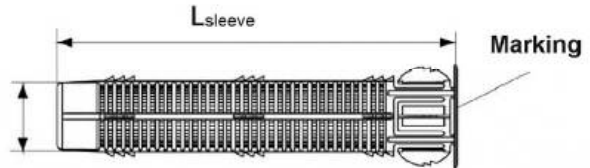

fischer Internal threaded anchor FIS E

FIS E 11x85 M6, FIS E 11x85 M8

FIS E 15x85 M10, FIS E 15x85 M12

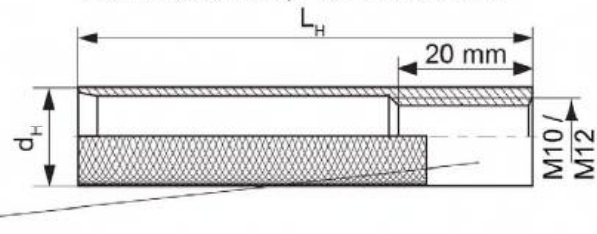
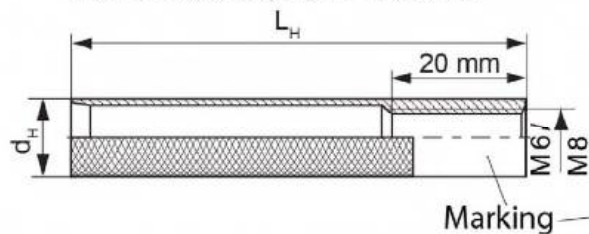

Marking

Installation conditions:

Anchor rod with perforated sleeve

Internal threaded anchor with perforated sleeve

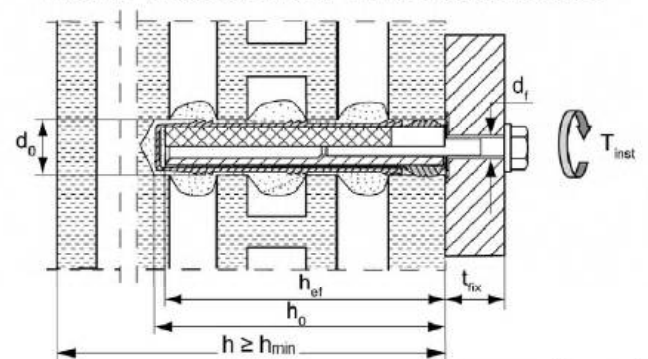
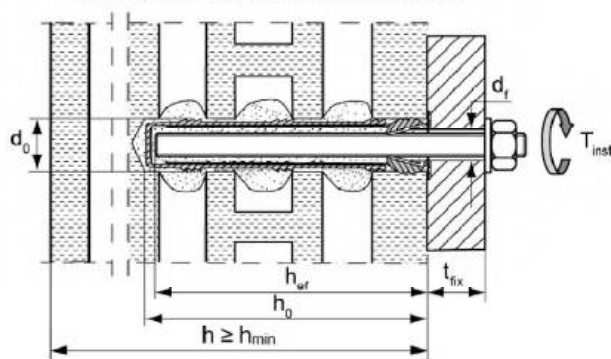

Figures not to scale

fischer injection system FIS V Plus for masonry

Intended Use

Installation parameters for anchor rods and internal threaded anchors FIS E with perforated sleeve (pre-positioned anchorage)

Annex B 6

Appendix 13 / 153

Table B7.1: Installation parameters for anchor rods with perforated sleeves (push through anchorage)

Perforated sleeve FIS H K		18x130/200		22x130/200
Nominal sleeve diameter	$D_{\text{sleeve,nom}}$ [mm]	16		20
Nominal drill hole diameter	d_0 [mm]	18		22
Depth of drill hole	h_0 [mm]	135		
Effective anchorage depth	h_{ef} [mm]	≥ 130		
Diameter of cleaning brush ¹⁾	$d_b \geq$ [mm]	see Table B8.1		
Size of threaded rod	[-]	M10	M12	M16
Maximum installation torque	T_{inst} [Nm]	see parameters of brick		
Thickness of fixture	$t_{\text{fix,max}}$ [mm]	200		

¹⁾ Only for solid areas in hollow bricks and solid bricks.

Perforated sleeve

FIS H 18x130/200 K; FIS H 22x130/200 K

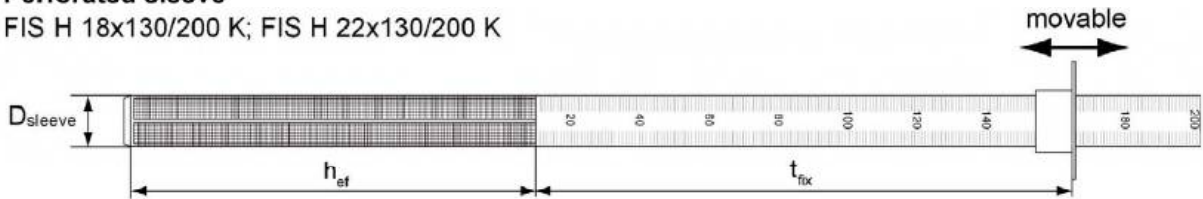

Installation conditions:

Anchor rod with perforated sleeve

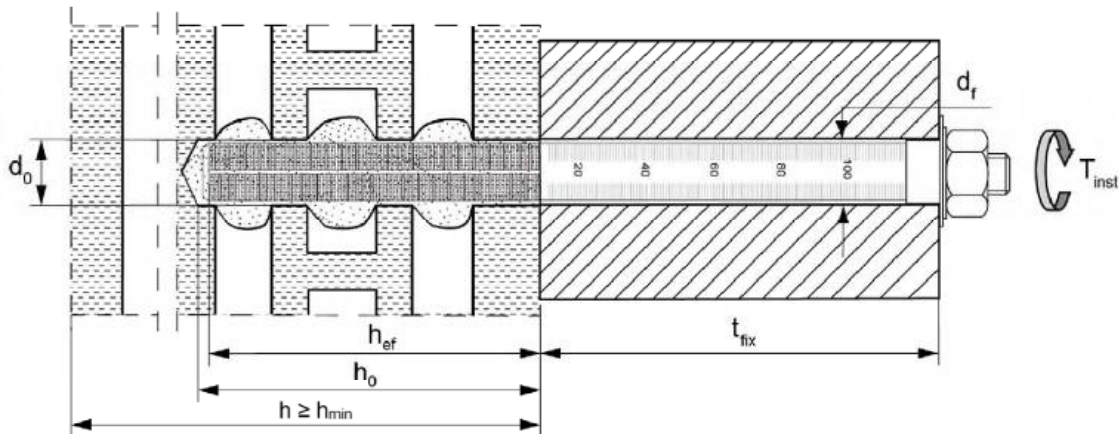

Figures not to scale

fischer injection system FIS V Plus for masonry

Intended Use
Installation parameters for anchor rods with perforated sleeves (push through anchorage)

Annex B 7

Appendix 14 / 153

Table B8.1: Parameters of the cleaning brush BS (steel brush with steel bristles)

The size of the cleaning brush refers to the drill hole diameter

Drill hole diameter	d_0 [mm]	8	10	12	14	16	18	20	22
Brush diameter	d_b [mm]	9	11	14	16	20	20	25	25

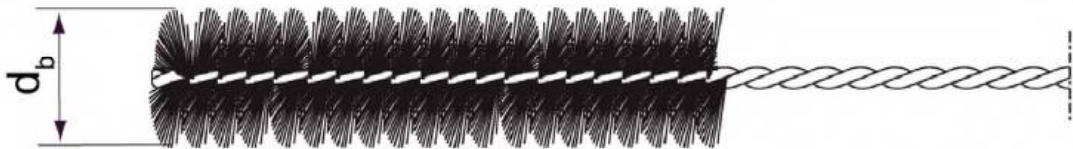

Only for solid bricks and autoclaved aerated concrete or solid areas of perforated bricks and hollow blocks

Table B8.2: Maximum processing times and minimum curing times
(During the curing time of the mortar the masonry temperature may not fall below the listed minimum temperature)

Temperature at anchoring base [°C]	Maximum processing time ²⁾ t_{work}			Minimum curing time ^{1), 2)} t_{cure}		
	FIS VW Plus High Speed	FIS V Plus	FIS VS Plus Low Speed	FIS VW Plus High Speed	FIS V Plus ¹⁾	FIS VS Plus Low Speed
-10 to -5	>5 min	-	-	12 h	-	-
> -5 to 0	5 min	>13 min	-	3 h	24 h	-
> 0 to 5	5 min	13 min	>20 min	3 h	3 h	6 h
> 5 to 10	3 min	9 min	20 min	50 min	90 min	3 h
> 10 to 20	1 min	5 min	10 min	30 min	60 min	2 h
> 20 to 30	-	4 min	6 min	-	45 min	60 min
> 30 to 40	-	2 min	4 min	-	35 min	30 min

¹⁾ For wet bricks the curing time must be doubled.

²⁾ Minimum cartridge temperature +5°C.

Figures not to scale

fischer injection system FIS V Plus for masonry





Intended Use
Cleaning brush (steel brush)
Maximum processing times and minimum curing times

Annex B 8

Appendix 15 / 153

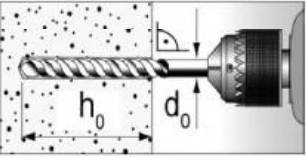
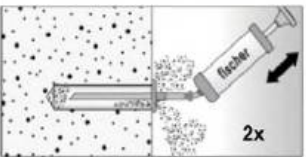
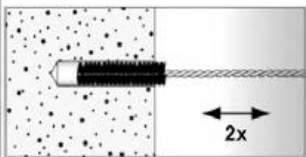
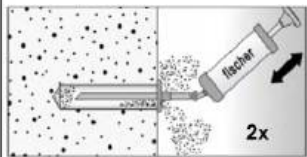
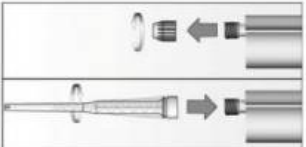
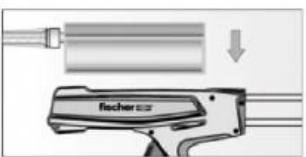
Installation instruction part 1

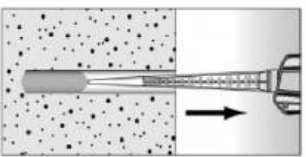
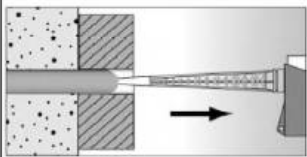
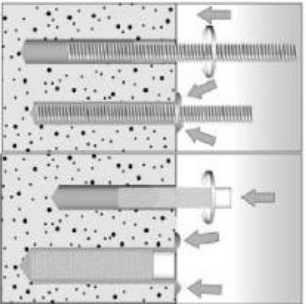
Installation in solid brick and autoclaved aerated concrete (without perforated sleeve)

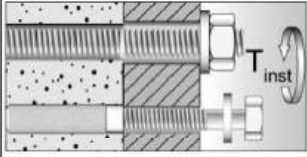
1		<p>Drill the hole (drilling method see Annex C of the respective brick) depth of drill hole h_0 and drill hole diameter d_0 see Table B4.1; B5.1</p>	
2			 <p>Blow out the drill hole twice. Brush twice and blow out twice again.</p>
3		<p>Remove the sealing cap. Screw on the static mixer. (the spiral in the static mixer must be clearly visible).</p>	
4		<p>Place the cartridge into a suitable dispenser</p>	 <p>Press out approximately 10 cm of mortar until the resin is permanently grey in colour. Mortar which is not grey in colour will not cure and must be disposed of.</p>
5		<p>Fill approximately 2/3 of the drill hole with mortar beginning from the bottom of the hole¹⁾. Avoid bubbles!</p>	 <p>For push through anchorage fill the annular clearance with mortar.</p>
6		<p>Only use clean and oil-free metal parts. Mark the anchor rod for setting depth. Insert the anchor rod or internal threaded anchor FIS E by hand using light turning motions. When reaching the setting depth marking, excess mortar must emerge from the mouth of the drill hole.</p>	
7		<p>Do not touch. Minimum curing time see Table B8.2</p>	 <p>Mounting the fixture. max T_{inst} see parameter of brick in Annex C.</p>

¹⁾ Exact volume of mortar see manufacturer's specification.

fischer injection system FIS V Plus for masonry





Intended Use
Installation instruction (without perforated sleeve) part 1

Annex B 9

Appendix 16 / 153

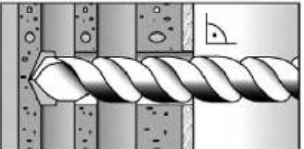
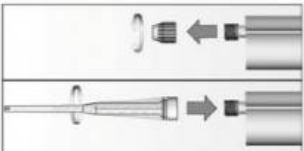
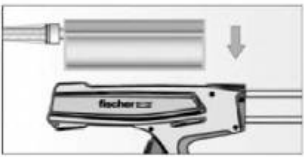
Installation instruction part 2

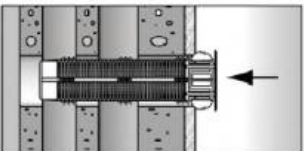
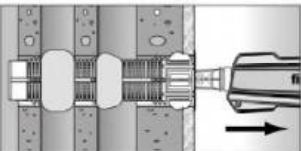
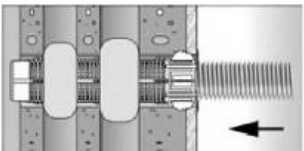
Installation in perforated or solid brick with perforated sleeve (pre-positioned anchorage)

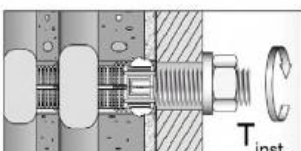
1		<p>Drill the hole (drilling method see Annex C of the respective brick). depth of drill hole h_0 and drill hole diameter d_0 see Table B6.1</p>	<p>When install perforated sleeves in solid bricks or solid areas of hollow bricks, also clean the hole by blowing out and brushing.</p>	
2		<p>Remove the sealing cap. Screw on the static mixer. (the spiral in the static mixer must be clearly visible).</p>		
3		<p>Place the cartridge into a suitable dispenser.</p>		<p>Press out approximately 10 cm of mortar until the resin is permanently grey in colour. Mortar which is not grey in colour will not cure and must be disposed of.</p>
4		<p>Insert the perforated sleeve flush with the surface of the masonry or plaster.</p>		<p>Fill the perforated sleeve completely with mortar beginning from the bottom of the hole¹⁾.</p>
5		<p>Only use clean and oil-free metal parts. Mark the anchor rod for setting depth. Insert the anchor rod or the internal threaded anchor FIS E by hand using light turning motions until reaching the setting depth marking (anchor rod) or flush with the surface (internal threaded anchor).</p>		
6		<p>Do not touch. Minimum curing time see Table B8.2</p>		<p>Mounting the fixture. max T_{inst} see parameter of brick in Annex C.</p>

¹⁾ Exact volume of mortar see manufacturer's specification.

fischer injection system FIS V Plus for masonry

Intended Use
Installation instruction (with perforated sleeve) part 2

Annex B 10

Appendix 17 / 153

Installation instruction part 3



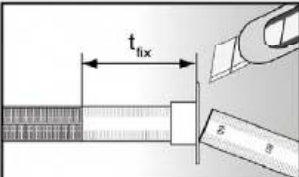
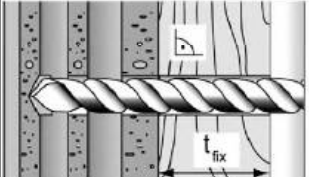
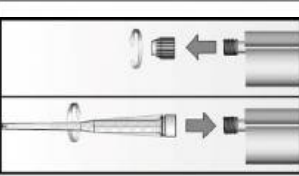
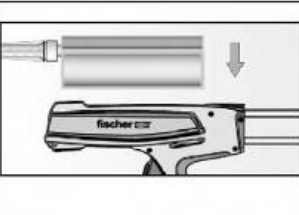
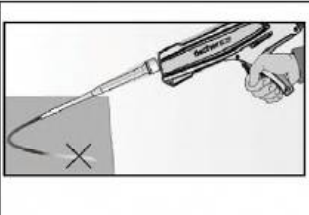
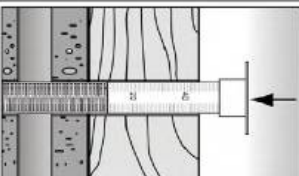
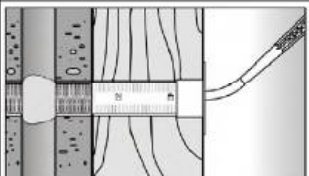
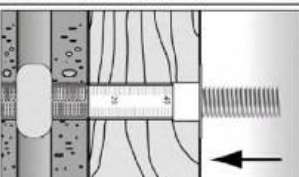
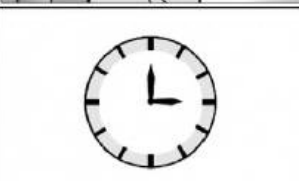
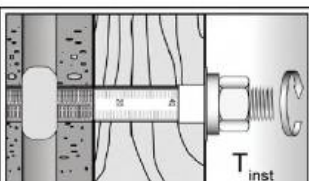

Installation in perforated or solid brick with perforated sleeve (push through anchorage)

1		<p>Push the movable stop up to the correct thickness of fixture and cut the overlap.</p>		<p>Drill the hole through the fixture. Depth of drill hole ($h_0 + t_{fix}$) and drill hole diameter see Table B7.1.</p>
2		<p>Remove the sealing cap. Screw on the static mixer. (the spiral in the static mixer must be clearly visible).</p>		
3		<p>Place the cartridge into a suitable dispenser.</p>		<p>Press out approximately 10 cm of mortar until the resin is permanently grey in colour. Mortar which is not grey in colour will not cure and must be disposed of.</p>
4		<p>Insert the perforated sleeve flush with the surface of the fixture into the drill hole.</p>		<p>Fill the sleeve with mortar beginning from the bottom of the hole.¹⁾ For deep drill holes use an extension tube.</p>
5		<p>Only use clean and oil-free metal parts. Mark the anchor rod for setting depth. Insert the anchor rod or the internal threaded anchor FIS E by hand using light turning motions until reaching the setting depth marking (anchor rod) or flush with the surface (internal threaded anchor).</p>		
6		<p>Do not touch. Minimum curing time see Table B8.2.</p>		<p>Mounting the fixture. max T_{inst} see parameter of brick in Annex C.</p>

¹⁾ Exact volume of mortar see manufacturer's specification.

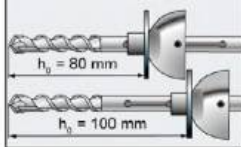
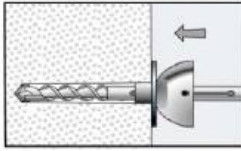
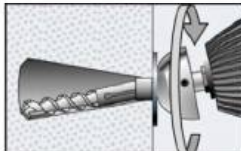
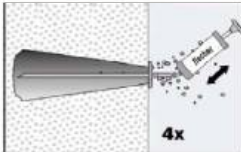
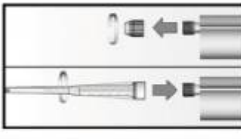
Installation instruction part 4

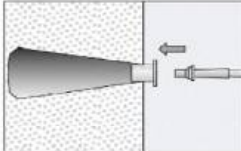
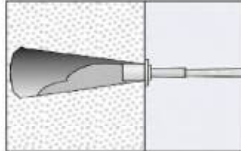
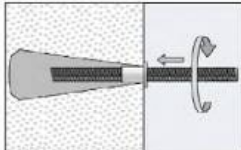
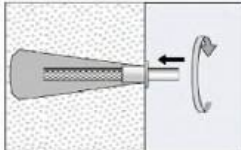
Installation in autoclaved aerated concrete with special conic drill bit PBB (pre-positioned anchorage)

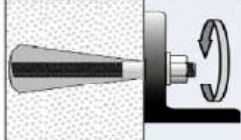
1		<p>Position the movable drill bit arrester on the used drill hole depth (see Table B4.1).</p> <p>For this, unlock the clamp screw and slide the arrester.</p> <p>Now fix the clamp screw.</p>	
2		<p>Drill the cylindrical hole with rotating drill until the arrester contact the material surface (drilling method see Annex C of the respective brick).</p>	
3		<p>Deviate the working power drill circulate to generate an conic undercut in the material.</p>	
4		<p>Blow out the drill hole four times.</p>	
5		<p>Remove the sealing cap. Screw on the static mixer. (the spiral in the static mixer must be clearly visible).</p>	
6		<p>Place the cartridge into a suitable dispenser.</p>	 <p>Press out approximately 10 cm of mortar until the resin is permanently grey in colour. Mortar which is not grey in colour will not cure and must be disposed of.</p>
7		<p>Put the center sleeve into the drill hole and adapt the injection adapter onto the static mixer.</p>	 <p>Fill the drill hole with injection mortar.</p>
8			<p>Only use clean and oil-free metal parts.</p> <p>Mark the anchor rod for setting depth.</p> <p>Insert the anchor rod or internal threaded anchor FIS E by hand using light turning motions.</p> <p>When reaching the setting depth marking, excess mortar must emerge from the mouth of the drill hole.</p>
9		<p>Do not touch.</p> <p>Minimum curing time see Table B8.2.</p>	 <p>Mounting the fixture.</p> <p>max T_{inst} see parameter of brick in Annex C.</p>

fischer injection system FIS V Plus for masonry

Intended Use

Installation instruction for autoclaved aerated concrete with special conic drill bit PBB (pre-positioned anchorage) part 4

Annex B 12

Appendix 19 / 153

Table B13.1: Overview of assessed bricks part 1

Kind of masonry	Brick format [mm]	Mean compressive strength [N/mm ²]	Main country of origin	Mean gross density ρ [kg/dm ³]	Annex
Solid brick Mz					
Solid brick Mz	NF $\geq 240 \times 115 \times 71$	12 / 20 / 28	Germany	$\geq 1,8$	C 4 – C 7
	2DF $\geq 240 \times 115 \times 113$	10 / 16	Germany	$\geq 1,8$	C 8 / C 9
	$\geq 245 \times 118 \times 54$	10 / 20	Italy	$\geq 1,8$	C 10 / C 11
	$\geq 230 \times 108 \times 55$	10 / 20	Denmark	$\geq 1,8$	C 12 / C 13
Solid calcium silicate (sand- lime) brick KS / perforated calcium silicate (sand- lime) brick KSL					
Solid calcium silicate brick KS	NF $\geq 240 \times 115 \times 71$	12 - 28	Germany	$\geq 2,0$	C 14 / C 15
	8DF $\geq 250 \times 240 \times 240$	10 - 28	Germany	$\geq 2,0$	C 16 / C 17
	$\geq 997 \times 214 \times 538$	10 - 36	Netherlands	$\geq 1,8$	C 18 / C 19
	$\geq 240 \times 115 \times 113$	10 / 20	Germany	$\geq 1,8$	C 20 – C 23
Perforated calcium silicate brick KSL	3DF $240 \times 175 \times 113$	8 - 20	Germany	$\geq 1,4$	C 24 – C 27
Vertical perforated brick HLz					
Vertical perforated brick HLz	$370 \times 240 \times 237$	4 - 12	Germany	$\geq 1,0$	C 28 / C 29
	$500 \times 175 \times 237$	4 - 12	Germany	$\geq 1,0$	C 28 / C 29
	2DF $240 \times 115 \times 113$	6 - 28	Germany	$\geq 1,4$	C 30 / C 31
	$248 \times 365 \times 248$	4 - 8	Germany	$\geq 0,6$	C 32 – C 35
	$248 \times 365 \times 249$	8 - 12	Germany	$\geq 0,7$	C 36 – C 39
	$248 \times 365 \times 249$	4 / 6	Germany	$\geq 0,5$	C 40 – C 43
	$248 \times 425 \times 248$	4 - 8	Germany	$\geq 0,8$	C 44 – C 47
	$248 \times 425 \times 248$	4 - 8	Germany	$\geq 0,8$	C 48 – C 51
	$500 \times 200 \times 315$	4 - 8	Germany	$\geq 0,6$	C 52 – C 55
	$500 \times 200 \times 300$	4 - 10	France	$\geq 0,7$	C 56 – C 59
	$500 \times 200 \times 315$	2 - 8	France	$\geq 0,7$	C 60 – C 63
	$560 \times 200 \times 275$	4 - 8	France	$\geq 0,7$	C 64 / C 65
	$255 \times 120 \times 118$	2 - 12	Italy	$\geq 1,0$	C 66 - C 68
	$275 \times 130 \times 94$	6 - 20	Spain	$\geq 0,8$	C 69 / C 71
	$220 \times 190 \times 290$	6 - 10	Portugal	$\geq 0,7$	C 72 – C 75
	$253 \times 300 \times 240$	2 - 6	Austria	$\geq 0,8$	C 76 – C 79
	$250 \times 440 \times 250$	6 - 10	Austria	$\geq 0,7$	C 80 – C 83
	$230 \times 108 \times 55$	2 - 8	Denmark	$\geq 1,4$	C 84 / C 85
	$365 \times 248 \times 245$	8	Austria	$\geq 0,6$	C 86 / C 89
	$240 \times 175 \times 113$	10	Germany	$\geq 0,9$	C 90 / C 93

fischer injection system FIS V Plus for masonry

Intended Use
 Overview of assessed bricks part 1

Annex B 13

Appendix 20 / 153

Table B14.1: Overview of assessed bricks part 2

Kind of masonry	Brick format [mm]	Mean compressive strength [N/mm ²]	Main country of origin	Mean gross density ρ [kg/dm ³]	Annex
Horizontal perforated brick LLz					
Horizontal perforated brick LLz	248x78x250	2 - 6	Italy	≥0,7	C 94 / C 95
	128x88x275	2	Spain	≥0,8	C 96 / C 97
Light-weight concrete hollow block Hbl					
Light-weight concrete hollow block Hbl	362x240x240	2 / 4	Germany	≥1,0	C 98 – C 101
	500x200x200	2 - 6	France	≥1,0	C 102 / C 103
	440x215x215	4 - 10	Ireland	≥1,2	C 104 – C 107
Light-weight concrete solid block Vbl					
Light-weight concrete solid block Vbl	≥ 372x300x254	2	Germany	≥0,6	C 108 / C 109
	≥ 250x240x239	4 - 8	Germany	≥1,6	C 110 – C 113
	≥ 440x100x215	4 - 10	Ireland	≥2,0	C 114 / C 115
	≥ 440x95x215	6 - 12	England	≥2,0	C 116 / C 117
Autoclaved aerated concrete (AAC)					
PP2 / AAC	-	2	Germany	0,35	C 118 – C 122
PP4 / AAC	-	4	Germany	0,5	C 118 – C 122
PP6 / AAC	-	6	Germany	0,65	C 118 – C 122

fischer injection system FIS V Plus for masonry

Intended Use
Overview of assessed bricks part 2

Annex B 14

Appendix 21 / 153

Table B15.1: Overview dimensions of perforated and hollow bricks part 1

Solid calcium silicate brick KS, 8DF,
EN 771-2:2011+A1:2015 according to Annex C 16

Perforated calcium silicate brick KSL, 3DF,
EN 771-2:2011+A1:2015; e.g. KS Wending
according to Annex C 24

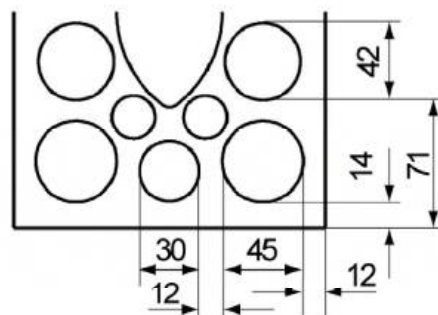
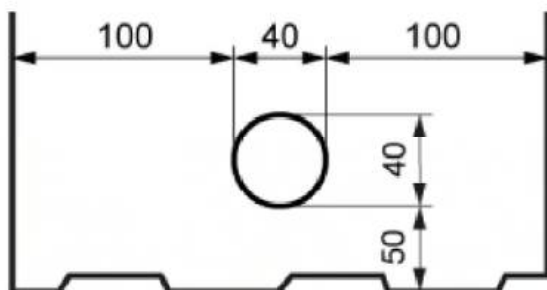

Vertical perforated brick HLz, EN 771-1:2011+A1:2015: e.g. Wienerberger, Poroton according to Annex C 28

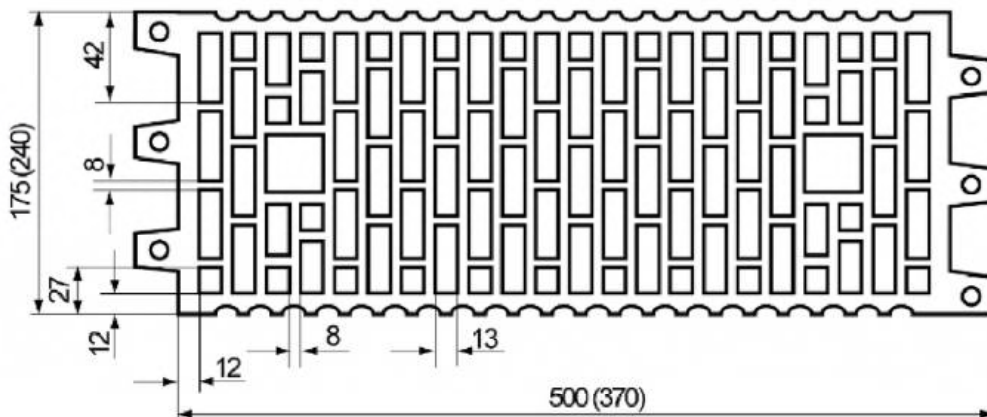

Vertical perforated brick HLz, 2DF,
EN 771-1:2011+A1:2015; e.g. Wienerberger
according to Annex C 30

Vertical perforated brick HLz, U8,
EN 771-1:2011+A1:2015; according to Annex C 32

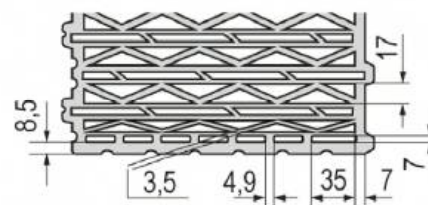
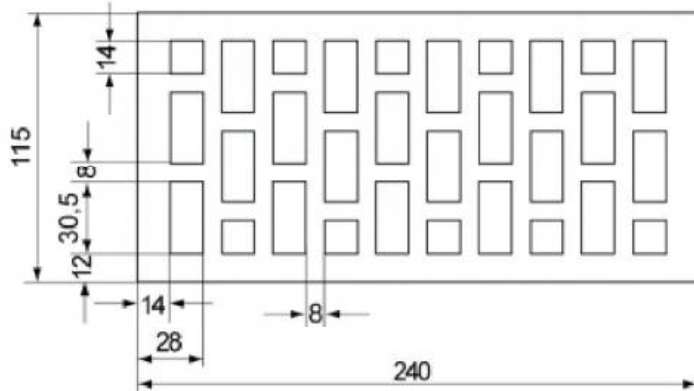

Measures in [mm]

Figures not to scale

fischer injection system FIS V Plus for masonry

Intended Use
Overview dimensions of perforated and hollow bricks part 1

Annex B 15

Appendix 22 / 153

Table B16.1: Overview dimensions of perforated and hollow bricks part 2

Vertical perforated brick HLz, T10, T11, EN 771-1:2011+A1:2015; according to Annex C36

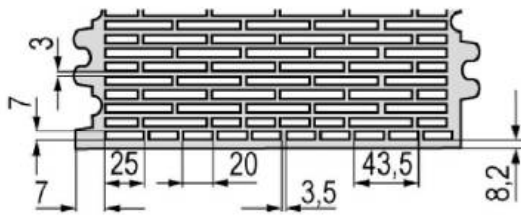

Vertical perforated brick HLz, T7 PF, filled with perlite, EN 771-1:2011+A1:2015; according to Annex C 40

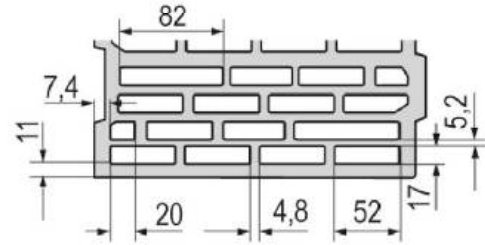

Vertical perforated brick HLz, T9 MW, filled with mineral wool, EN 771-1:2011+A1:2015; according to Annex C 44

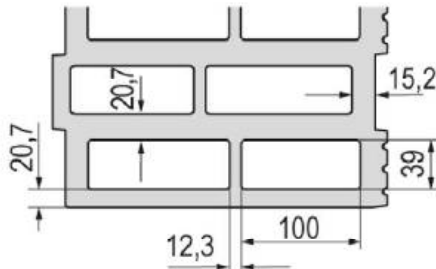

Vertical perforated brick HLz, FZ 7, filled with mineral wool, EN 771-1:2015, according to Annex C 48

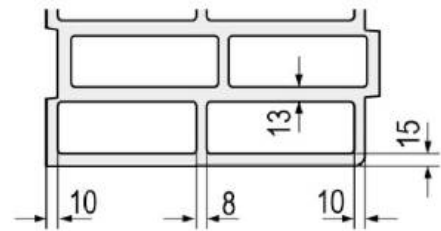

Vertical perforated brick HLz, EN 771-1:2011+A1:2015; e.g. Bouyer Leroux; According to Annex C 52

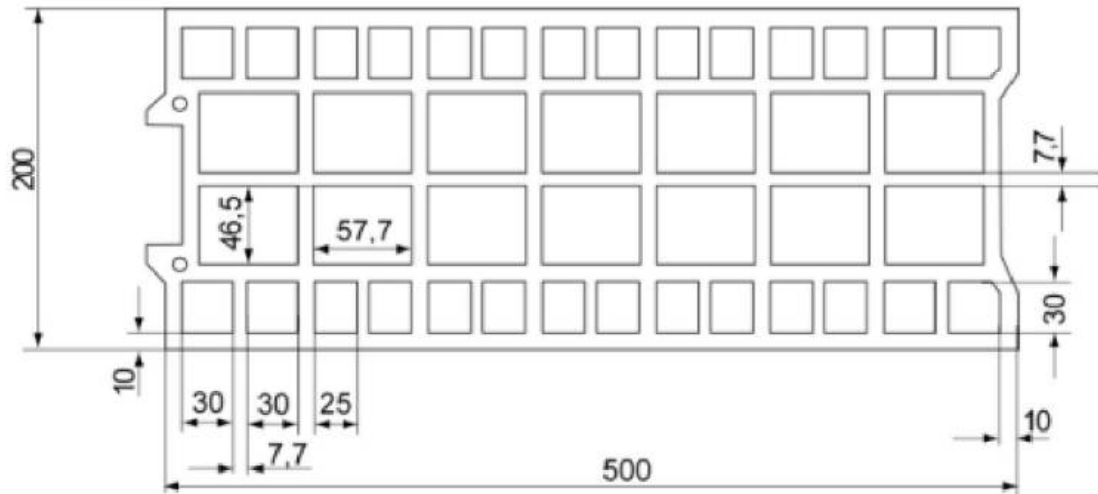

Measures in [mm]

Figures not to scale

fischer injection system FIS V Plus for masonry

Intended Use
Overview dimensions of perforated and hollow bricks part 2

Annex B 16

Appendix 23 / 153

Table B17.1: Overview dimensions of perforated and hollow bricks part 3

Vertical perforated brick HLz, EN 771-1:2011+A1:2015; e.g. Wienerberger according to Annex C 56

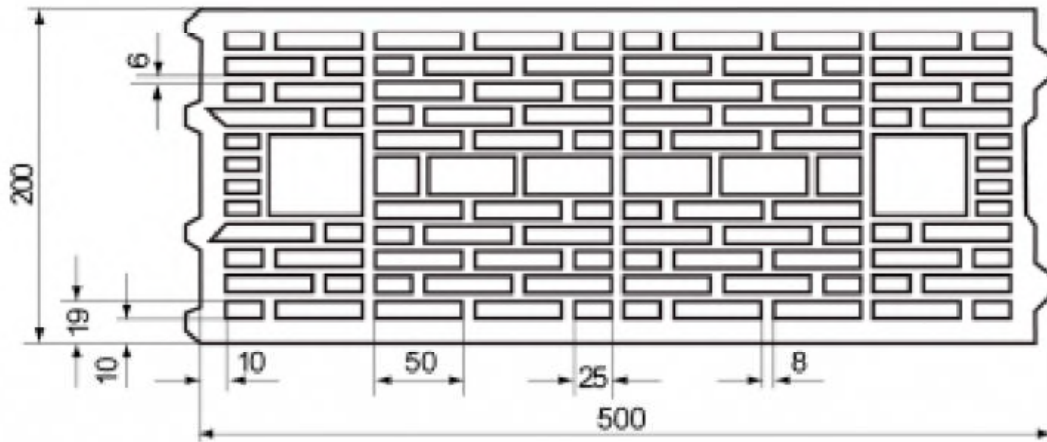

Vertical perforated brick HLz, EN 771-1:2011+A1:2015; e.g. Terreal according to Annex C 60

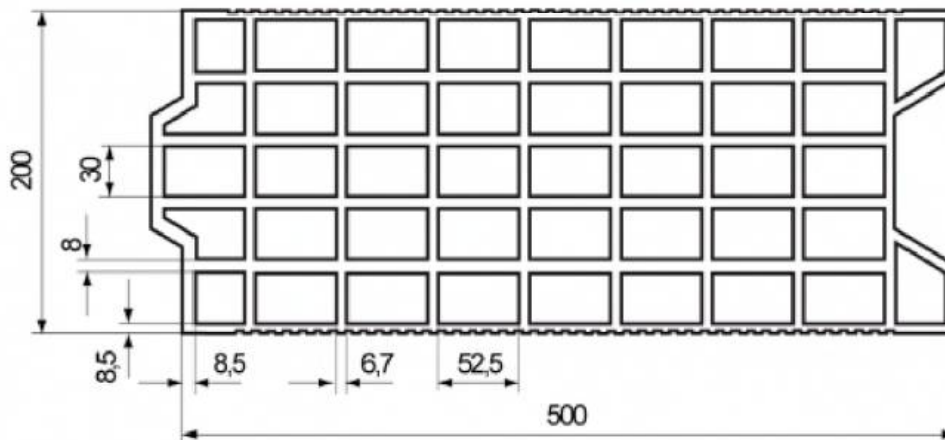

Vertical perforated brick HLz, EN 771-1:2011+A1:2015; e.g. Imery according to Annex C 64

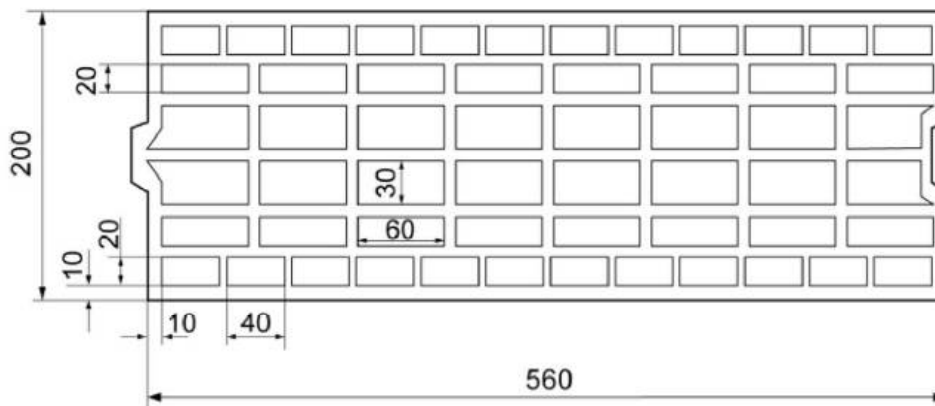

Measures in [mm]

Figures not to scale

fischer injection system FIS V Plus for masonry

Intended Use
Overview dimensions of perforated and hollow bricks part 3

Annex B 17

Appendix 24 / 153

Table B18.1: Overview dimensions of perforated and hollow bricks part 4

Vertical perforated brick HLz,
EN 771-1:2011+A1:2015;
e.g. Wienerberger according to Annex C 66

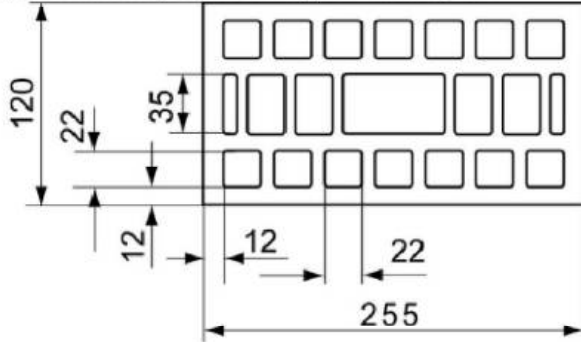

Vertical perforated brick HLz,
EN 771-1:2011+A1:2015;
e.g. Ceramica Farreny S.A. according to Annex C 69

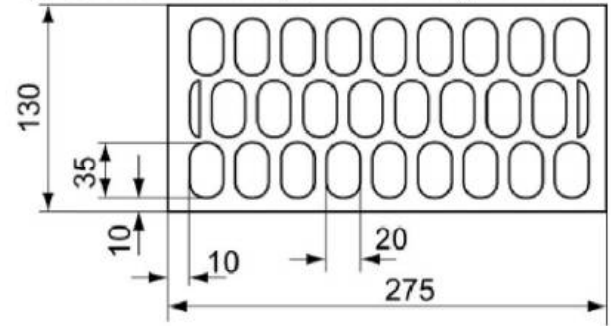

Vertical perforated brick HLz,
EN 771-1:2011+A1:2015;
e.g. Perceram according to Annex C 72

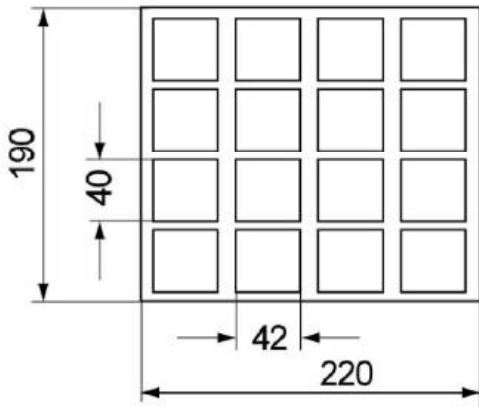

Vertical perforated brick HLz,
EN 771-1:2011+A1:2015;
e.g. Ziegelwerk Brenna according to Annex C 76

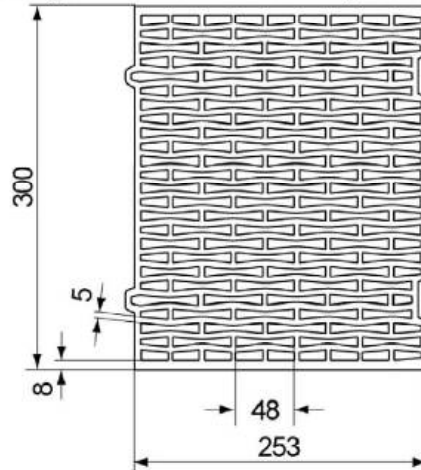

Vertical perforated brick HLz, Porotherm W 44, filled
with mineral wool, EN 771-1:2011+A1:2015 according
to Annex C 80

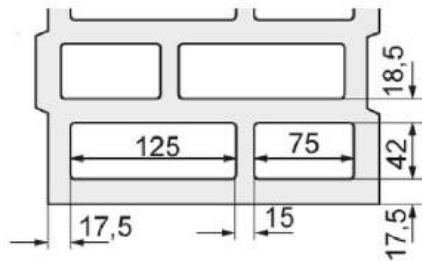

Vertical perforated brick HLz,
EN 771-1:2011+A1:2015;
e.g. Wienerberger according to Annex C 84

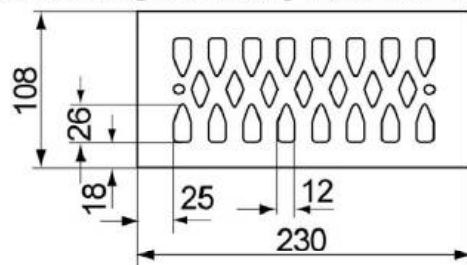

Measures in [mm]

Figures not to scale

fischer injection system FIS V Plus for masonry

Intended Use
Overview dimensions of perforated and hollow bricks part 4

Annex B 18

Appendix 25 / 153

Table B19.1: Overview dimensions of perforated and hollow bricks part 5

Vertical perforated brick filled with mineral wool,
EN 771-1:2011+A1:2015; according to Annex C 86

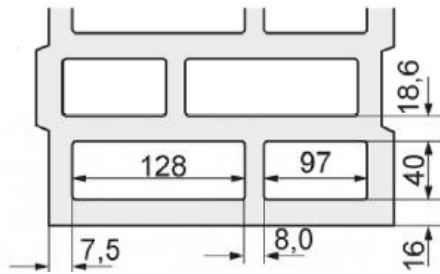

Vertical perforated brick HLz,
EN 771-1:2011+A1:2015;
e.g. Wienerberger according to Annex C 90

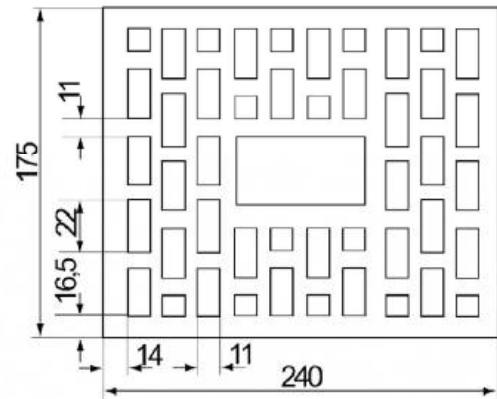

Horizontal perforated brick LLz,
EN 771-1:2011+A1:2015; according to Annex C 94

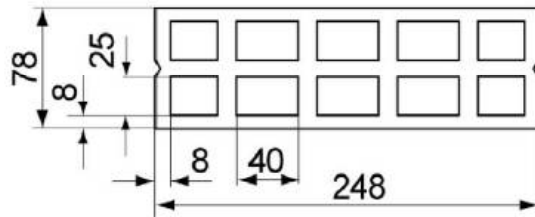

Horizontal perforated brick LLz,
EN 771-1:2011+A1:2015;
e.g. Cermanica Farreny S.A according to Annex C 96

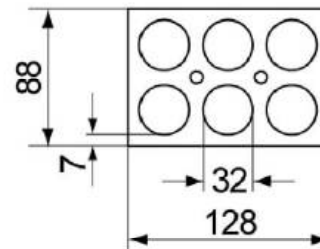

Light-weight concrete hollow block Hbl,
EN 771-3:2011+A1:2015; according to Annex C 98

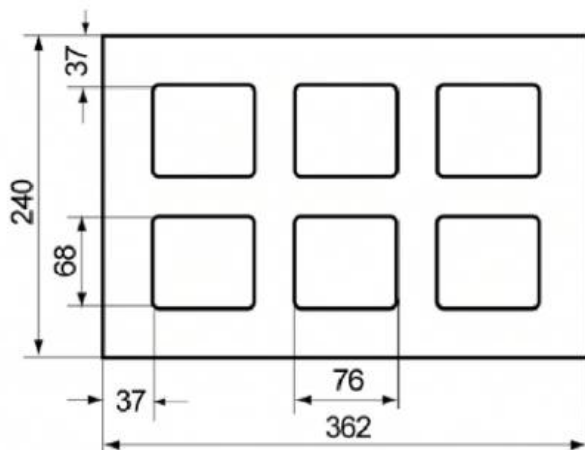

Light-weight concrete hollow block Hbl,
EN 771-3:2011+A1:2015;
e.g. Sepa according to Annex C 102

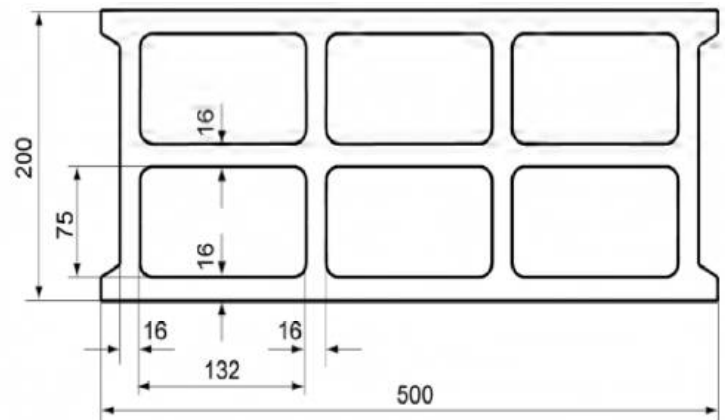

Measures in [mm]
Figures not to scale

fischer injection system FIS V Plus for masonry

Intended Use
Overview dimensions of perforated and hollow bricks part 5

Annex B 19

Appendix 26 / 153

Table B20.1: Overview dimensions of perforated and hollow bricks part 6

Light-weight concrete hollow block Hbl,
EN 771-3:2011+A1:2015
e.g. Roadstone wood according to Annex C 104

Light-weight concrete hollow block Hbl,
EN 771-3:2011+A1:2015
e.g. Sepa according to Annex C 108

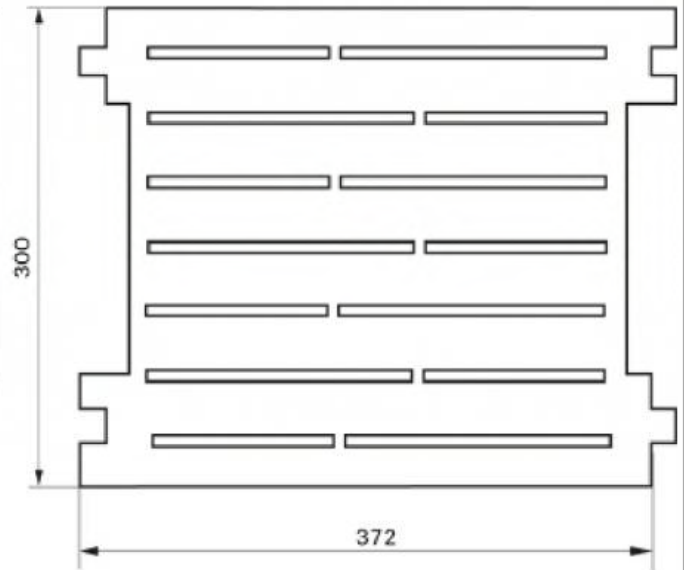
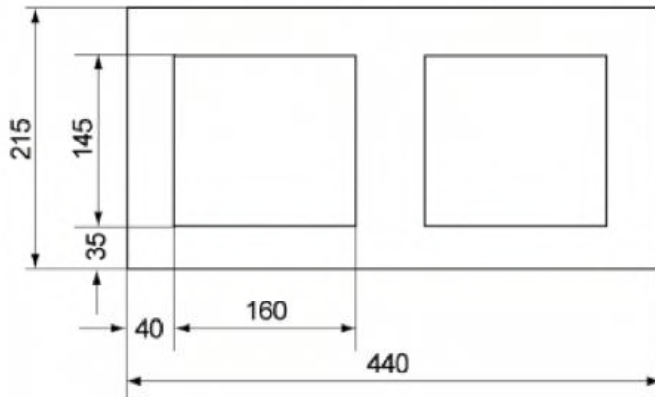

Light-weight concrete solid block Vbl,
EN 771-3:2011+A1:2015;
e.g. Sepa according to Annex C 110

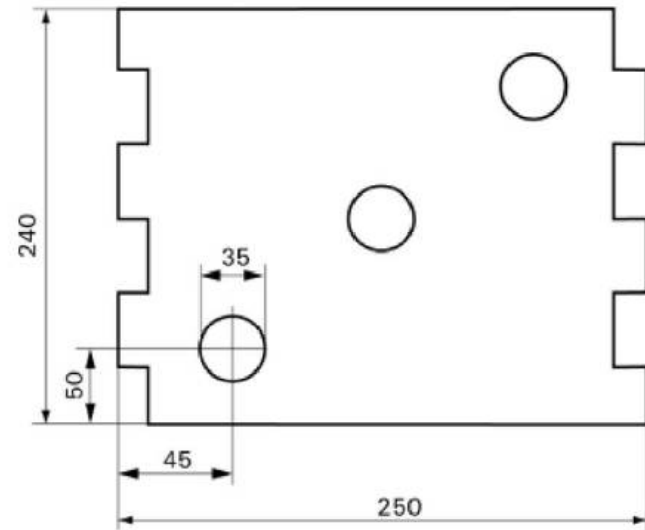

Measures in [mm]
Figures not to scale

fischer injection system FIS V Plus for masonry

Intended Use
Overview dimensions of perforated and hollow bricks part 6

Annex B 20

Appendix 27 / 153

Spacing and edge distance part 1

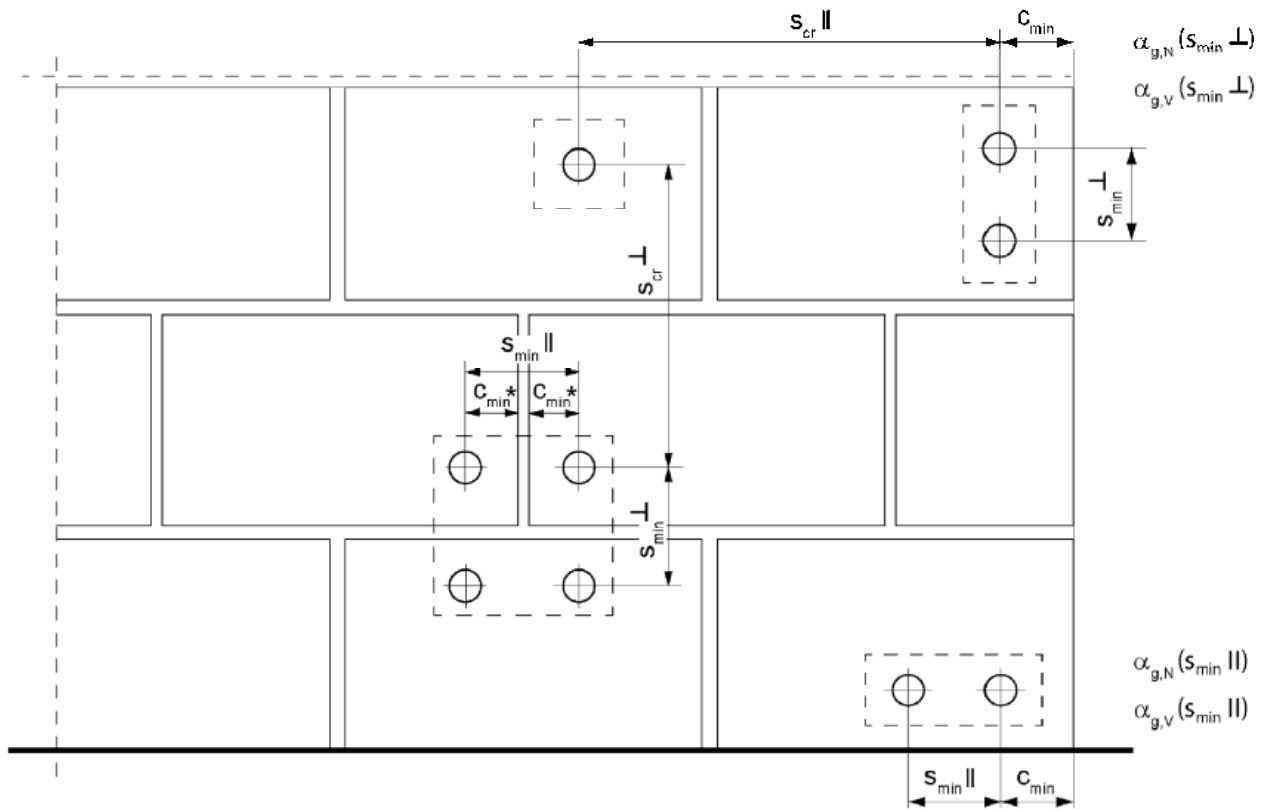

* Only, if vertical joints are not completely filled with mortar

$s_{min II}$	=	Minimum spacing parallel to horizontal joint
$s_{min \perp}$	=	Minimum spacing perpendicular to horizontal joint
$s_{cr II}$	=	Characteristic spacing parallel to horizontal joint
$s_{cr \perp}$	=	Characteristic spacing perpendicular to horizontal joint
$c_{cr} = c_{min}$	=	Edge distance
$\alpha_{g,N}(s_{min II})$	=	Group factor for tension load, anchor group parallel to horizontal joint
$\alpha_{g,V}(s_{min II})$	=	Group factor for shear load, anchor group parallel to horizontal joint
$\alpha_{g,N}(s_{min \perp})$	=	Group factor for tension load, anchor group perpendicular to horizontal joint
$\alpha_{g,V}(s_{min \perp})$	=	Group factor for shear load, anchor group perpendicular to horizontal joint

Figures not to scale

fischer injection system FIS V Plus for masonry

Intended Use
Spacing and edge distance part 1

Annex B 21

Appendix 28 / 153

Spacing and edge distance part 2

For $s \geq s_{cr}$: $\alpha_g = 2$

For $s_{min} \leq s < s_{cr}$: α_g according to installation parameters of brick Annex C

Group of 2 anchors

$$N^{g_{RK}} = \alpha_{g,N} \cdot N_{RK} ; \quad V^{g_{RK,b}} = V^{g_{RK,c,II}} = V^{g_{RK,c,\perp}} = \alpha_{g,V} \cdot V_{RK}$$

Group of 4 anchors

$$N^{g_{RK}} = \alpha_{g,N}(s_{minII}) \cdot \alpha_{g,N}(s_{min\perp}) \cdot N_{RK} ;$$

$$V^{g_{RK,b}} = V^{g_{RK,c,II}} = V^{g_{RK,c,\perp}} = \alpha_{g,V}(s_{minII}) \cdot \alpha_{g,V}(s_{min\perp}) \cdot V_{RK}$$

with N_{RK} and $\alpha_{g,N}$ depending on s_{minII} or $s_{min\perp}$ acc. to Annex C

with V_{RK} and $\alpha_{g,V}$ depending on s_{minII} or $s_{min\perp}$ acc. to Annex C

fischer injection system FIS V Plus for masonry

Intended Use
Spacing and edge distance part 2

Annex B 22

Appendix 29 / 153

Table C1.1: Characteristic resistance to steel failure of a single anchor under tension loading of fischer anchor rods and standard threaded rods

Anchor rod / standard threaded rod		M6	M8 ³⁾	M10 ³⁾	M12	M16			
Characteristic resistance to steel failure under tension loading									
Characteristic resistance $N_{Rk,s}$	Steel zinc plated	4.6	[kN]	8,0	14,6(13,2)	23,2(21,4)	33,7	62,8	
		4.8		8,0	14,6(13,2)	23,2(21,4)	33,7	62,8	
		5.8		10,0	18,3(16,6)	29,0(26,8)	42,1	78,5	
		8.8		16,0	29,2(26,5)	46,4(42,8)	67,4	125,6	
	Stainless steel R and High corrosion resistant steel HCR	Property class		50	10,0	18,3	29,0	42,1	78,5
				70	14,0	25,6	40,6	59,0	109,9
				80	16,0	29,2	46,4	67,4	125,6

Partial factors ¹⁾

Partial factors $\gamma_{Ms,N}$	Steel zinc plated	4.6	[-]	2,00				
		4.8		1,50				
		5.8		1,50				
		8.8		1,50				
	Stainless steel R and High corrosion resistant steel HCR	Property class		50	2,86			
				70	1,50 ²⁾ / 1,87			
				80	1,60			

¹⁾ In absence of other national regulations

²⁾ Only for fischer FIS A made of high corrosion resistant steel HCR

³⁾ Values in brackets are valid for undersized threaded rods with smaller stress area A_s for hot-dip galvanised standard threaded rods according to EN ISO 10684:2004+AC:2009

fischer injection system FIS V Plus for masonry

Performance

Characteristic resistance to steel failure of a single anchor under tension loading of fischer anchor rods and standard threaded rods

Annex C 1

Appendix 30 / 153

Table C2.1: Characteristic resistance to steel failure of a single anchor under shear loading with and without lever arm of fischer anchor rods and standard threaded rods

Anchor rod / standard threaded rod		M6	M8 ³⁾	M10 ³⁾	M12	M16			
Characteristic resistance to steel failure under shear loading									
without lever arm									
Characteristic resistance $V_{Rk,s}$	Steel zinc plated	Property class	4.6	4,8	8,7(7,9)	13,9(12,8)	20,2	37,6	
			4.8	4,8	8,7(7,9)	13,9(12,8)	20,2	37,6	
		Stainless steel R and High corrosion resistant steel HCR	Property class	5.8	6,0	10,9(9,9)	17,4(16,0)	25,2	47,1
				8.8	8,0	14,6(13,2)	23,2(21,4)	33,7	62,8
	Stainless steel R and High corrosion resistant steel HCR	Property class	50	5,0	9,1	14,5	21,0	39,2	
			70	7,0	12,8	20,3	29,5	54,9	
			80	8,0	14,6	23,2	33,7	62,8	
				8,0	14,6	23,2	33,7	62,8	
with lever arm									
Characteristic resistance $M_{Rk,s}^0$	Steel zinc plated	Property class	4.6	6,1	14,9(12,9)	29,9(26,5)	52,3	132,9	
			4.8	6,1	14,9(12,9)	29,9(26,5)	52,3	132,9	
		Stainless steel R and High corrosion resistant steel HCR	Property class	5.8	7,6	18,7(16,1)	37,3(33,2)	65,4	166,2
				8.8	12,2	29,9(25,9)	59,8(53,1)	104,6	265,9
	Stainless steel R and High corrosion resistant steel HCR	Property class	50	7,6	18,7	37,3	65,4	166,2	
			70	10,6	26,2	52,3	91,5	232,6	
			80	12,2	29,9	59,8	104,6	265,9	
				12,2	29,9	59,8	104,6	265,9	
Partial factors¹⁾									
Partial factors $\gamma_{Ms,V}$	Steel zinc plated	Property class	4.6	1,67					
			4.8	1,25					
		Stainless steel R and High corrosion resistant steel HCR	Property class	5.8	1,25				
				8.8	1,25				
	Stainless steel R and High corrosion resistant steel HCR	Property class	50	2,38					
			70	1,25 ²⁾ / 1,56					
			80	1,33					
				1,33					

¹⁾ In absence of other national regulations

²⁾ Only for fischer FIS A made of high corrosion resistant steel HCR

³⁾ Values in brackets are valid for undersized threaded rods with smaller stress area A_s for hot-dip galvanised standard threaded rods (M8 resp. M10) according to EN ISO 10684:2004+AC:2009.

fischer injection system FIS V Plus for masonry

Performance

Characteristic resistance to steel failure of a single anchor under shear loading with and without lever arm of fischer anchor rods and standard threaded rods

Annex C 2

Appendix 31 / 153

Table C3.1: Characteristic resistance to steel failure of a single anchor under tension / shear loading of internal threaded anchors FIS E

fischer internal threaded anchor FIS E			M6	M8	M10	M12	
Characteristic resistance to steel failure under tension loading, decisive values of sleeve and screw/threaded rod							
Characteristic resistance with screw	$N_{Rk,s}$	Property class 4.6	[kN]	8,0	14,6	23,2	33,7
		Property class 5.8		10,0	18,3	29,0	42,1
		Property class R		14,0	25,6	40,6	59,0
		Property class 70 HCR		14,0	25,6	40,6	59,0
Partial factors¹⁾							
Partial factors	$\gamma_{Ms,N}$	Property class 4.6	[-]	2,00			
		Property class 5.8		1,50			
		Property class R		1,87			
		Property class 70 HCR		1,87			
Characteristic resistance to steel failure under shear loading; decisive values of sleeve and screw/threaded rod							
without lever arm							
Characteristic resistance with screw	$V_{Rk,s}$	Property class 4.6	[kN]	4,8	8,7	13,9	20,2
		Property class 5.8		5	9	15	21
		Property class R		7,0	12,8	20,3	29,5
		Property class 70 HCR		7,0	12,8	20,3	29,5
with lever arm							
Characteristic resistance	$M^0_{Rk,s}$	Property class 4.6	[Nm]	6,1	14,9	29,9	52,3
		Property class 5.8		7,6	18,7	37,3	65,4
		Property class R		10,6	26,2	52,3	91,5
		Property class 70 HCR		10,6	26,2	52,3	91,5
Partial factors¹⁾							
Partial factors	$\gamma_{Ms,V}$	Property class 4.6	[-]	1,67			
		Property class 5.8		1,25			
		Property class R		1,56			
		Property class 70 HCR		1,56			
¹⁾ In absence of other national regulations							

fischer injection system FIS V Plus for masonry

Performance

Characteristic resistance to steel failure of a single anchor under tension / shear loading of internal threaded anchors FIS E

Annex C 3

Appendix 32 / 153

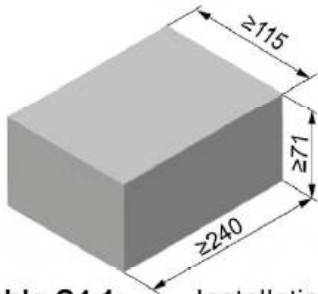
Solid brick Mz, NF, EN 771-1:2011+A1:2015

Producer	e.g. Wienerberger		
Nominal dimensions [mm]	length L	width W	height H
	≥ 240	≥ 115	≥ 71
Mean gross dry density ρ [kg/dm ³]	≥ 1,8		
Mean compressive strength / Min. compressive strength single brick ¹⁾ [N/mm ²]	15 / 12 or 25 / 20 35 / 28		
Standard or annex	EN 771-1:2011+A1:2015		

Table C4.1: Installation parameters for edge distance $c=100\text{mm}$

Anchor rod	M6	M8	M10	M12	-	-			
Internal threaded anchor FIS E	-	-	-	-	M6	M8	M10	M12	
					11x85		15x85		
Anchor rod and internal threaded anchor FIS E without perforated sleeve									
Effective anchorage depth h_{ef}	[mm]	50	50	50	50	85			
		80	80	80	80				
		200	200	200	200				
Max. installation torque $\max T_{inst}$	[Nm]	4	10			4	10		
General installation parameters									
Edge distance $c_{min} = c_{or}$	[mm]	100				100			
Edge distance $h_{ef}=200$ $c_{min} = c_{or}$		150				- ²⁾			
Spacing		$s_{min II,N}$	60				60		
		$h_{ef}=200$ $s_{min II,N}$	240				- ²⁾		
		$s_{min II,V}$	240				240		
		$s_{cr II}$	240				240		
		$s_{cr \perp} = s_{min \perp}$	75				75		

Drilling method

Hammer drilling with hard metal hammer drill

¹⁾ The compressive strength of the single brick must not be less than 80% of the mean compressive strength.

²⁾ No performance assessed

Table C4.2: Group factors

Anchor rods	M6	M8	M10	M12	-	-			
Internal threaded anchor FIS E	-	-	-	-	M6	M8	M10	M12	
					11x85		15x85		
Edge distance c_{min}	[mm]	100							
Group factor	$\alpha_{a,N} (s_{min II})$	[-]	1,5						
	$\alpha_{g,V} (s_{min II})$		2,0						
	$h_{ef}=200$ $\alpha_{g,N} (s_{min II})$		1,5						
	$h_{ef}=200$ $\alpha_{g,V} (s_{min II})$		2,0						
	$\alpha_{a,N} (s_{min \perp})$		2,0						
	$\alpha_{g,V} (s_{min \perp})$		2,0						
	$h_{ef}=200$ $\alpha_{a,N} (s_{min \perp})$		2,0						
	$h_{ef}=200$ $\alpha_{g,V} (s_{min \perp})$		2,0						

fischer injection system FIS V Plus for masonry

Performance

 Solid brick Mz, NF, dimensions, installation parameters $c=100\text{mm}$
Annex C 4

Appendix 33 / 153

Solid brick Mz, NF, EN 771-1:211+A1:2015
Table C5.1: Characteristic resistance to pull-out failure or brick breakout failure of a single anchor under tension loading for edge distance $c=100\text{mm}$

Anchor rod		M6	M8	M10			M12			-	-		
Internal threaded anchor FIS E		-	-	-			-			M6	M8	M10	M12
										11x85		15x85	
Tension resistance $N_{Rk} = N_{Rk,p} = N_{Rk,b} = N_{Rk,p,c} = N_{Rk,b,c}$ [kN] depending on the mean compressive strength f_b; Installation and use condition w/w, w/d, d/d; (temperature range 50/80°C)²⁾													
Mean compressive strength / Min. compressive strength single brick ¹⁾	Use conditions	Effective anchorage depth h_{ef} [mm]											
		≥ 50	≥ 50	50	80	200	50	80	200	85			
15 / 12 N/mm²	w/w w/d	2,5	2,5	2,0	3,0	7,5	2,0	3,5	5,0	3,5			
	d/d	4,0	4,0	3,5	5,0	12,0	3,0	5,5	8,0	5,5			
25 / 20 N/mm²	w/w w/d	3,5	3,5	3,0	4,5	11,0	3,0	5,0	7,0	5,0			
	d/d	5,5	5,5	5,0	7,0	12,0	4,5	8,0	11,5	8,0			

¹⁾ The compressive strength of the single brick must not be less than 80% of the mean compressive strength.

²⁾ For temperature range 72/120°C: $N_{Rk(72/120^\circ\text{C})} = 0,83 \cdot N_{Rk(50/80^\circ\text{C})}$.

Table C5.2: Characteristic resistance to local brick failure or brick edge failure of a single anchor under shear loading for edge distance $c=100\text{mm}$

Anchor rod		M6	M8	M10			M12			-	-		
Internal threaded anchor FIS E		-	-	-			-			M6	M8	M10	M12
										11x85		15x85	
Shear resistance $V_{Rk} = V_{Rk,b} = V_{Rk,c,II} = V_{Rk,c,I}$ [kN] depending on the mean compressive strength f_b; Installation and use condition w/w, w/d, d/d; (temperature range 50/80°C and 72/120°C)													
Mean compressive strength / Min. compressive strength single brick ¹⁾	Use conditions	Effective anchorage depth h_{ef} [mm]								85			
		≥ 50	≥ 50	≥ 50	200	≥ 50	200						
15 / 12 N/mm²	w/w w/d	2,5	2,5	4,0	8,5	4,0	11,5	2,5					
	d/d	4,0	4,0	6,0	12,0	5,5	12,0	4,0					
25 / 20 N/mm²	w/w w/d	4,0	4,0	6,0	12,0	5,5	12,0	4,0					
	d/d	4,0	4,0	6,0	12,0	5,5	12,0	4,0					

¹⁾ The compressive strength of the single brick must not be less than 80% of the mean compressive strength.

Factor for job site tests and displacements see annex C 123.

fischer injection system FIS V Plus for masonry

Performance

 Solid brick Mz, NF, Characteristic resistance under tension and shear loading
 $c=100\text{mm}$
Annex C 5

Appendix 34 / 153

Solid brick Mz, NF, EN 771-1:2011+A1:2015

Table C6.1: Installation parameters for edge distance $c=60\text{mm}$

Anchor rod	M6	M8	M10	M12	M16	-	-			
Internal threaded anchor FIS E	-	-	-	-	-	M6	M8	M10	M12	
	11x85		15x85							
Anchor rod and internal threaded anchor FIS E without perforated sleeve										
Effective anchorage depth h_{ef} [mm]	50	50	50	50	50	85				
	100	100	100	100	100					
	200	200	200	200	200					
Max. installation torque $\max T_{inst}$ [Nm]	4	10				4	10			

General installation parameters

Edge distance $c_{min} = c_{cr}$		60
Edge distance $h_{ef}=200$	c_{min}	60
Spacing	$s_{min \parallel, N}$	80
	$h_{ef}=200$ $s_{min \parallel, N}$ [mm]	80
	$s_{min \parallel, V}$	80
	$s_{cr \parallel}$	$3x h_{ef}$
	$s_{min \perp}$	80
	$s_{cr \perp}$	$3x h_{ef}$

Drilling method

Hammer drilling with hard metal hammer drill

Table C6.2: Group factors

Anchor rods	M6	M8	M10	M12	M16	-	-		
Internal threaded anchor FIS E	-	-	-	-	-	M6	M8	M10	M12
	11x85		15x85						
Edge distance c_{min} [mm]	60								
Group factor	$\alpha_{g, N} (s_{min \parallel})$	[-]	0,6						
	$\alpha_{g, V} (s_{min \parallel})$		1,3						
	$h_{ef}=200$ $\alpha_{g, N} (s_{min \parallel})$		1,4						
	$h_{ef}=200$ $\alpha_{g, V} (s_{min \parallel})$		1,5						
	$\alpha_{g, N} (s_{min \perp})$		0,3						
	$\alpha_{g, V} (s_{min \perp})$		1,3						
	$h_{ef}=200$ $\alpha_{g, N} (s_{min \perp})$		2,0						
	$h_{ef}=200$ $\alpha_{g, V} (s_{min \perp})$		1,1						

fischer injection system FIS V Plus for masonry

Performance
Solid brick Mz, NF, dimensions, installation parameters $c=60\text{mm}$

Annex C 6

Solid brick Mz, NF, EN 771-1:2011+A1:2015

Table C7.1: Characteristic resistance to pull-out failure or brick breakout failure of a single anchor under tension loading for edge distance $c=60\text{mm}$

Anchor rod	M6	M8	M10	M12	M16	-		-	
Internal threaded anchor FIS E	-	-	-	-	-	M6	M8	M10	M12
	11x85		15x85						

Tension resistance $N_{Rk} = N_{Rk,p} = N_{Rk,b} = N_{Rk,p,c} = N_{Rk,b,c}$ [kN] depending on the mean compressive strength f_b ; Installation and use condition w/w, w/d, d/d; (temperature range 50/80°C)³⁾

Mean compressive strength / Min. compressive strength single brick ¹⁾	Use conditions		Effective anchorage depth h_{ef} [mm]												85
			50	100	50	100	50	100	200	50	100	200	50	100	
15 / 12 N/mm ²	w/w	w/d	1,5	2,0	2,0	2,0	2,5	- ²⁾	2,0	2,5	- ²⁾	2,0	5,5	- ²⁾	- ²⁾
	d/d		2,5	3,0	4,0	3,0	4,0	9,5	3,0	4,0	9,5	3,0	8,5	9,5	- ²⁾
25 / 20 N/mm ²	w/w	w/d	2,0	2,5	3,0	2,5	3,5	- ²⁾	3,0	3,5	- ²⁾	3,0	7,5	- ²⁾	- ²⁾
	d/d		3,5	4,5	5,5	4,5	5,5	12	4,5	5,5	12	4,5	12	12	- ²⁾
35 / 28 N/mm ²	w/w	w/d	2,5	3,0	4,0	3,0	4,0	- ²⁾	3,5	4,0	- ²⁾	3,5	9,0	- ²⁾	- ²⁾
	d/d		4,0	5,5	6,5	5,5	6,5	12	5,5	6,5	12	5,5	12	12	- ²⁾

1) The compressive strength of the single brick must not be less than 80% of the mean compressive strength.

2) No performance assessed

3) For temperature range 72/120°C: $N_{Rk(72/120^\circ\text{C})} = 0,83 \cdot N_{Rk(50/80^\circ\text{C})}$.

Table C7.2: Characteristic resistance to local brick failure or brick edge failure of a single anchor under shear loading for edge distance $c=60\text{mm}$

Anchor rod	M6	M8	M10	M12	M16	-		-	
Internal threaded anchor FIS E	-	-	-	-	-	M6	M8	M10	M12
	11x85		15x85						

Shear resistance $V_{Rk} = V_{Rk,b} = V_{Rk,c,II} = V_{Rk,c,I}$ [kN] depending on the mean compressive strength f_b ; Installation and use condition w/w, w/d, d/d; (temperature range 50/80°C and 72/120°C)

Mean compressive strength / Min. compressive strength single brick ¹⁾	Use conditions		Effective anchorage depth h_{ef} [mm]												85	
			50	100	50	100	50	100	200	50	100	200	50	100		200
15 / 12 N/mm ²	w/w	w/d	1,2	2,5	1,2	3,0	2,0	3,0	1,5	1,5	3,0	3,0	0,6	3,0	4,5	- ²⁾
25 / 20 N/mm ²		w/d	1,5	3,5	1,5	4,5	3,0	4,5	2,5	2,0	4,5	4,5	0,9	4,5	6,0	- ²⁾
35 / 28 N/mm ²		d/d	2,0	4,0	2,0	5,0	3,5	5,0	3,0	2,5	5,0	5,0	1,2	5,0	7,5	- ²⁾

1) The compressive strength of the single brick must not be less than 80% of the mean compressive strength.

2) No performance assessed.

Factor for job site tests and displacements see annex C 123.

fischer injection system FIS V Plus for masonry

Performance

Solid brick Mz, NF, Characteristic resistance under tension and shear loading $c=60\text{mm}$

Annex C 7

Appendix 36 / 153

Solid brick Mz, 2DF, EN 771-1:2011+A1:2015

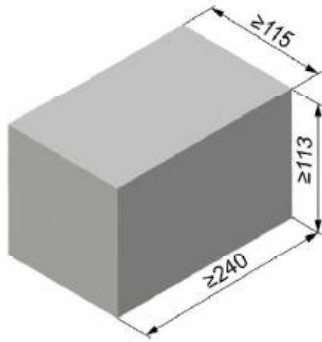

Producer	e.g. Wienerberger		
Nominal dimensions [mm]	length L	width W	height H
	≥ 240	≥ 115	≥ 113
Mean gross dry density ρ [kg/dm ³]	≥ 1,8		
Mean compressive strength / Min. compressive strength single brick ¹⁾ [N/mm ²]	12,5 / 10 or 20 / 16		
Standard or annex	EN 771-1:2011+A1:2015		

Table C8.1: Installation parameters

Anchor rod	M6	M8	M10	M12	M16	-		-		
Internal threaded anchor FIS E	-	-	-	-	-	M6	M8	M10	M12	
	11x85		15x85							
Anchor rod and internal threaded anchor FIS E without perforated sleeve										
Effective anchorage depth h_{ef} [mm]	50	100	50	100	50	100	50	100	85	
Max. installation torque $\max T_{inst}$ [Nm]	4		10				4	10		
Anchor rod and internal threaded anchor FIS E with perforated sleeve FIS H 16x85 K										
Effective anchorage depth h_{ef} [mm]	- ²⁾		85		- ²⁾		85		- ²⁾	
Max. installation torque $\max T_{inst}$ [Nm]	-		10		-		4	10	-	
General installation parameters										
Edge distance $c_{min} = c_{cr}$					60					
Spacing	$s_{min \parallel}$					120				
	$s_{cr \parallel}$					240				
	$s_{cr \perp} = s_{min \perp}$					115				

Drilling method

Hammer drilling with hard metal hammer drill

¹⁾ The compressive strength of the single brick must not be less than 80% of the mean compressive strength.

²⁾ No performance assessed.

Table C8.2: Group factors

Anchor rods	M6	M8	M10	M12	M16	-		-		
Internal threaded anchor FIS E	-	-	-	-	-	M6	M8	M10	M12	
	11x85		15x85							
Group factor	$\alpha_{g,N} (s_{min \parallel})$					1,5				
	$\alpha_{g,V} (s_{min \parallel})$					1,4				
	$\alpha_{g,N} (s_{min \perp})$					2,0				
	$\alpha_{g,V} (s_{min \perp})$									

fischer injection system FIS V Plus for masonry

Performance
Solid brick Mz, 2DF, dimensions, installation parameters

Annex C 8

Appendix 37 / 153

Solid brick Mz, 2DF, EN 771-1:2011+A1:2015

Table C9.1: Characteristic resistance to pull-out failure or brick breakout failure of a single anchor under tension loading

Anchor rod	M6	M8	M10	M12	M16	-	-	M8	M10	-			
Internal threaded anchor FIS E	-	-	-	-	-	M6	M8	M10	M12	-	-	M6	M8
						11x85	15x85					11x85	
Perforated sleeve FIS H K	-	-	-	-	-	-	-	-	-	-	16x85		

Tension resistance $N_{Rk} = N_{Rk,p} = N_{Rk,b} = N_{Rk,p,c} = N_{Rk,b,c}$ [kN] depending on the mean compressive strength f_b ; Installation and use condition w/w, w/d, d/d; (temperature range 50/80°C)²⁾

Mean compressive strength / Min. compressive strength single brick ¹⁾	Use conditions	Effective anchorage depth h_{ef} [mm]													
		50	100	50	100	50	100	50	100	50	100	85			
12,5 / 10 N/mm²	w/w w/d	1,5	2,5	1,5	2,5	1,5	3,0	2,0	3,5	2,0	3,5	2,0		1,5	
	d/d	3,0	4,0	3,0	4,0	3,0	4,5	3,0	5,5	3,0	5,5	3,0		3,0	
20 / 16 N/mm²	w/w w/d	2,5	4,0	2,5	4,0	2,5	4,5	3,5	5,5	3,5	5,5	3,5		2,5	
	d/d	4,5	7,0	4,5	7,0	4,5	7,5	5,5	8,0	5,5	8,0	5,5		4,5	

- ¹⁾ The compressive strength of the single brick must not be less than 80% of the mean compressive strength.
²⁾ For temperature range 72/120°C: $N_{Rk(72/120°C)} = 0,83 \cdot N_{Rk(50/80°C)}$.

Table C9.2: Characteristic resistance to local brick failure or brick edge failure of a single anchor under shear loading

Anchor rod	M6	M8	M10	M12	M16	-	-	M8	M10	-			
Internal threaded anchor FIS E	-	-	-	-	-	M6	M8	M10	M12	-	-	M6	M8
						11x85	15x85					11x85	
Perforated sleeve FIS H K	-	-	-	-	-	-	-	-	-	-	16x85		

Shear resistance $V_{Rk} = V_{Rk,b} = V_{Rk,c,II} = V_{Rk,c,\perp}$ [kN] depending on the mean compressive strength f_b ; Installation and use condition w/w, w/d, d/d; (temperature range 50/80°C and 72/120°C)

Mean compressive strength / Min. compressive strength single brick ¹⁾	Use conditions	Effective anchorage depth h_{ef} [mm]													
		≥ 50						85							
12,5 / 10 N/mm²	w/w w/d	2,5	3,0	3,0	3,5	3,0	2,5	3,0	3,0	3,0	3,0	3,0	3,5	2,5	3,0
	d/d														
20 / 16 N/mm²	w/w w/d	4,0	5,0	5,5	5,5	5,0	4,0	5,0	5,0	5,0	5,0	5,0	6,0	4,0	5,0
	d/d														

- ¹⁾ The compressive strength of the single brick must not be less than 80% of the mean compressive strength. Factor for job site tests and displacements see annex C 123.

fischer injection system FIS V Plus for masonry

Performance
 Solid brick Mz, 2DF, Characteristic resistance under tension and shear loading

Annex C 9

Solid brick Mz, EN 771-1:2011+A1:2015

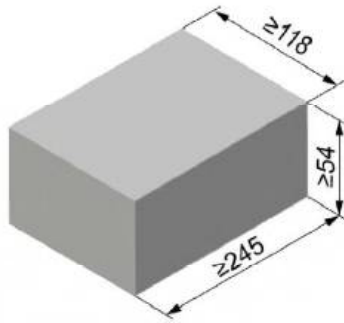

Producer		e.g. Nigra		
Nominal dimensions	[mm]	length L	width W	height H
		≥ 245	≥ 118	≥ 54
Mean gross dry density ρ	[kg/dm ³]	≥ 1,8		
Mean compressive strength / Min. compressive strength single brick ¹⁾	[N/mm ²]	12,5 / 10 or 25 / 20		
Standard or annex		EN 771-1:2011+A1:2015		

Table C10.1: Installation parameters

Anchor rod		M6	M8	M10	M12	M16	-	-			
Internal threaded anchor FIS E		-	-	-	-	-	M6	M8	M10	M12	
							11x85		15x85		
Anchor rod and internal threaded anchor FIS E without perforated sleeve											
Effective anchorage depth h_{ef}	[mm]	50	100	50	100	50	100	50	100	85	
Max. installation torque $\max T_{inst}$	[Nm]	4		10				4	10		
General installation parameters											
Edge distance $c_{min} = c_{cr}$		60									
Spacing	$s_{cr \parallel} = s_{min \parallel}$	245									
	$s_{cr \perp} = s_{min \perp}$	60									

Drilling method

Hammer drilling with hard metal hammer drill

¹⁾ The compressive strength of the single brick must not be less than 80% of the mean compressive strength.

Table C10.2: Group factors

Anchor rods		M6	M8	M10	M12	M16	-	-		
Internal threaded anchor FIS E		-	-	-	-	-	M6	M8	M10	M12
							11x85		15x85	
Group factor	$\alpha_{g,N} (s_{min \parallel})$	[-]	2							
	$\alpha_{g,V} (s_{min \parallel})$									
	$\alpha_{g,N} (s_{min \perp})$									
	$\alpha_{g,V} (s_{min \perp})$									

fischer injection system FIS V Plus for masonry

Performance
Solid brick Mz, dimensions, installation parameters

Annex C 10

Appendix 39 / 153

Solid brick Mz, EN 771-1:2011+A1:2015

Table C11.1: Characteristic resistance to pull-out failure or brick breakout failure of a single anchor under tension loading

Anchor rod		M6	M8	M10	M12	M16	-		-	
Internal threaded anchor FIS E		-	-	-	-	-	M6	M8	M10	M12
		11x85		15x85						
Tension resistance $N_{Rk} = N_{Rk,p} = N_{Rk,b} = N_{Rk,p,c} = N_{Rk,b,c}$ [kN] depending on the mean compressive strength f_b ; Installation and use condition w/w, w/d, d/d; (temperature range 50/80°C) ²⁾										
Mean compressive strength / Min. compressive strength single brick ¹⁾	Use conditions	Effective anchorage depth h_{ef} [mm]								
		≥ 50						85		
12,5 / 10 N/mm ²	w/w	0,60	0,90	0,75	0,75	0,75	0,60	0,75		
	w/d	1,20	1,50	1,20	1,20	1,20	1,20	1,20		
25 / 20 N/mm ²	w/w	0,90	1,50	1,20	1,20	1,20	0,90	1,20		
	w/d	1,50	2,50	2,00	2,00	2,00	1,50	2,00		

¹⁾ The compressive strength of the single brick must not be less than 80% of the mean compressive strength.

²⁾ For temperature range 72/120°C: $N_{Rk(72/120^\circ C)} = 0,83 \cdot N_{Rk(50/80^\circ C)}$.

Table C11.2: Characteristic resistance to local brick failure or brick edge failure of a single anchor under shear loading

Anchor rod		M6	M8	M10	M12	M16	-		-	
Internal threaded anchor FIS E		-	-	-	-	-	M6	M8	M10	M12
		11x85		15x85						
Shear resistance $V_{Rk} = V_{Rk,b} = V_{Rk,c,II} = V_{Rk,c,\perp}$ [kN] depending on the mean compressive strength f_b ; Installation and use condition w/w, w/d, d/d; (temperature range 50/80°C and 72/120°C)										
Mean compressive strength / Min. compressive strength single brick ¹⁾	Use conditions	Effective anchorage depth h_{ef} [mm]								
		≥ 50						85		
12,5 / 10 N/mm ²	w/w	2,0	3,0	4,0	4,5	5,5	2,0	3,0	4,0	4,5
	w/d									
25 / 20 N/mm ²	w/w	2,5	4,0	5,5	6,0	8,0	2,5	4,0	5,5	6,0
	w/d									

¹⁾ The compressive strength of the single brick must not be less than 80% of the mean compressive strength. Factor for job site tests and displacements see annex C 123.

fischer injection system FIS V Plus for masonry

Performance
Solid brick Mz, Characteristic resistance under tension and shear loading

Annex C 11

Appendix 40 / 153

Solid brick Mz, EN 771-1:2011+A1:2015

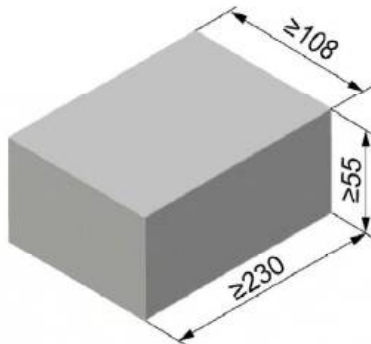

Producer	e.g. Wienerberger		
Nominal dimensions [mm]	length L	width W	height H
	≥ 230	≥ 108	≥ 55
Mean gross dry density ρ [kg/dm ³]	≥ 1,8		
Mean compressive strength / Min. compressive strength single brick ¹⁾ [N/mm ²]	12,5 / 10 or 25 / 20		
Standard or annex	EN 771-1:2011+A1:2015		

Table C12.1: Installation parameters

Anchor rod	M6	M8	M10	M12	M16	-		-	
Internal threaded anchor FIS E	-	-	-	-	-	M6	M8	M10	M12
	11x85		15x85						
Anchor rod and internal threaded anchor FIS E without perforated sleeve									
Effective anchorage depth h_{ef} [mm]	50	90	50	90	50	90	50	90	85
Max. installation torque $\max T_{inst}$ [Nm]	4		10				4		10
General installation parameters									
Edge distance $c_{min} = c_{cr}$	60								
Spacing $s_{cr \parallel} = s_{min \parallel}$ [mm]	230								
	$s_{cr \perp} = s_{min \perp}$	60							

Drilling method

Hammer drilling with hard metal hammer drill

¹⁾ The compressive strength of the single brick must not be less than 80% of the mean compressive strength.

Table C12.2: Group factors

Anchor rods	M6	M8	M10	M12	M16	-		-			
Internal threaded anchor FIS E	-	-	-	-	-	M6	M8	M10	M12		
	11x85		15x85								
Group factor	$\alpha_{g,N} (s_{min \parallel})$	[-]	2								
	$\alpha_{g,V} (s_{min \parallel})$										
	$\alpha_{g,N} (s_{min \perp})$										
	$\alpha_{g,V} (s_{min \perp})$										

fischer injection system FIS V Plus for masonry

Performance
Solid brick Mz, dimensions, installation parameters

Annex C 12

Appendix 41 / 153

Solid brick Mz, EN 771-1:2011+A1:2015

Table C13.1: Characteristic resistance to pull-out failure or brick breakout failure of a single anchor under tension loading

Anchor rod		M6	M8	M10	M12	M16	-		-	
Internal threaded anchor FIS E		-	-	-	-	-	M6	M8	M10	M12
		11x85		15x85						
Tension resistance $N_{Rk} = N_{Rk,p} = N_{Rk,b} = N_{Rk,p,c} = N_{Rk,b,c}$ [kN] depending on the mean compressive strength f_b ; Installation and use condition w/w, w/d, d/d; (temperature range 50/80°C) ²⁾										
Mean compressive strength / Min. compressive strength single brick ¹⁾	Use conditions	Effective anchorage depth h_{ef} [mm]								
		≥ 50						85		
12,5 / 10 N/mm ²	w/w	0,60	0,90	0,75	0,75	0,75	0,75			
	w/d	1,20	1,50	1,20	1,20	1,20	1,20			
25 / 20 N/mm ²	w/w	0,90	1,50	1,20	1,20	1,20	1,20			
	w/d	1,50	2,50	2,00	2,00	2,00	2,00			

¹⁾ The compressive strength of the single brick must not be less than 80% of the mean compressive strength.

²⁾ For temperature range 72/120°C: $N_{Rk(72/120^\circ C)} = 0,83 \cdot N_{Rk(50/80^\circ C)}$.

Table C13.2: Characteristic resistance to local brick failure or brick edge failure of a single anchor under shear loading

Anchor rod		M6	M8	M10	M12	M16	-		-	
Internal threaded anchor FIS E		-	-	-	-	-	M6	M8	M10	M12
		11x85		15x85						
Shear resistance $V_{Rk} = V_{Rk,b} = V_{Rk,c, } = V_{Rk,c,\perp}$ [kN] depending on the mean compressive strength f_b ; Installation and use condition w/w, w/d, d/d; (temperature range 50/80°C and 72/120°C)										
Mean compressive strength / Min. compressive strength single brick ¹⁾	Use conditions	Effective anchorage depth h_{ef} [mm]								
		≥ 50						85		
12,5 / 10 N/mm ²	w/w	2,0	3,0	4,0	4,5	5,5	2,0	3,0	4,0	4,5
	w/d									
25 / 20 N/mm ²	w/w	2,5	4,0	5,5	6,0	8,0	2,5	4,0	5,5	6,0
	w/d									

¹⁾ The compressive strength of the single brick must not be less than 80% of the mean compressive strength. Factor for job site tests and displacements see annex C 123.

fischer injection system FIS V Plus for masonry

Performance
Solid brick Mz, Characteristic resistance under tension and shear loading

Annex C 13

Appendix 42 / 153

Solid calcium silicate brick KS, NF, EN 771-2:2011+A1:2015

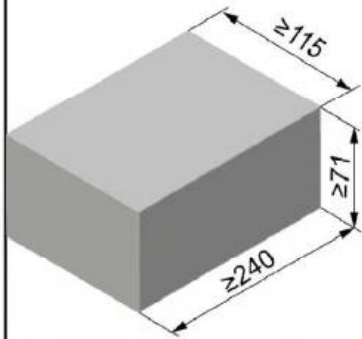

Producer	-		
Nominal dimensions [mm]	length L	width W	height H
	≥ 240	≥ 115	≥ 71
Mean gross dry density ρ [kg/dm ³]	≥ 1,8		
Mean compressive strength / Min. compressive strength single brick ¹⁾ [N/mm ²]	15 / 12 or 25 / 20 or 35 / 28		
Standard or annex	EN 771-2:2011+A1:2015		

Table C14.1: Installation parameters

Anchor rod	M6		M8		M10		M12		M16		-		-	
Internal threaded anchor FIS E	-		-		-		-		-		M6	M8	M10	M12
											11x85		15x85	
Anchor rod and internal threaded anchor FIS E without perforated sleeve														
Effective anchorage depth h_{ef} [mm]	50	100	50	100	50	100	50	100	50	100	85		85	
					200		200		200					
Max. installation torque $\max T_{inst}$ [Nm]	3		5		15		15		25		3	5	15	
General installation parameters														
Edge distance $c_{min} = c_{cr}$	Spacing	$s_{min} \parallel$	$s_{cr} \parallel$ [mm]	$s_{min} \perp$	$s_{cr} \perp$	60								
						80								
						80								
						3x h_{ef}								
						3x h_{ef}								
Drilling method														
Hammer drilling with hard metal hammer drill														

¹⁾ The compressive strength of the single brick must not be less than 80% of the mean compressive strength.

Table C14.2: Group factors

Anchor rod	M6		M8		M10		M12		M16		-		-	
Internal threaded anchor FIS E	-		-		-		-		-		M6	M8	M10	M12
											11x85		15x85	
Group factor	$\alpha_{g,N} (s_{min} \parallel)$	$\alpha_{g,V} (s_{min} \parallel)$	$\alpha_{g,N} (s_{min} \perp)$	$\alpha_{g,V} (s_{min} \perp)$	[-]	0,7								
						1,3								
						2,0								
						2,0								

fischer injection system FIS V Plus for masonry

Performance
Solid calcium silicate brick KS, NF, dimensions, installation parameters

Annex C 14

Appendix 43 / 153

Solid calcium silicate brick KS, NF, EN 771-2:2011+A1:2015

Table C15.1: Characteristic resistance to pull-out failure or brick breakout failure of a single anchor under tension loading

Anchor rod	M6	M8	M10	M12	M16	-	-		
Internal threaded anchor FIS E	-	-	-	-	-	M6	M8	M10	M12
						11x85		15x85	

Tension resistance $N_{Rk} = N_{Rk,p} = N_{Rk,b} = N_{Rk,p,c} = N_{Rk,b,c}$ [kN] depending on the mean compressive strength f_b ; Installation and use condition w/w, w/d, d/d; (temperature range 50/80°C)²⁾

Mean compressive strength / Min. compressive strength single brick ¹⁾	Use conditions	Effective anchorage depth h_{ef} [mm]														
		50	100	50	100	50	100	200	50	100	200	50	100	200	85	85
15 / 12 N/mm ²	w/w	2,0	3,0	2,5	4,5	2,5	3,5	7,0	2,5	3,0	6,5	2,5	3,5	8,0	2,5	2,5
	w/d	4,0	5,5	4,0	8,0	4,0	5,5	12	4,0	4,5	12	4,5	5,5	12	4,0	4,0
25 / 20 N/mm ²	w/w	3,0	4,5	3,5	6,5	3,5	4,5	10	3,5	4,0	9,5	4,0	5,0	11	3,5	3,5
	w/d	5,5	7,5	6,0	11	6,0	8,0	12	6,0	6,5	12	6,5	8,0	12	6,0	6,0
35 / 28 N/mm ²	w/w	3,5	5,0	4,0	8,0	4,5	5,5	12	4,5	5,0	11	4,5	5,5	12	4,5	4,5
	w/d	6,5	9,0	7,0	12	7,0	9,0	12	7,0	7,5	12	7,5	9,5	12	7,0	7,0

¹⁾ The compressive strength of the single brick must not be less than 80% of the mean compressive strength.

²⁾ For temperature range 72/120°C: $N_{Rk(72/120^\circ C)} = 0,83 \cdot N_{Rk(50/80^\circ C)}$.

Table C15.2: Characteristic resistance to local brick failure or brick edge failure of a single anchor under shear loading

Anchor rod	M6	M8	M10	M12	M16	-	-		
Internal threaded anchor FIS E	-	-	-	-	-	M6	M8	M10	M12
						11x85		15x85	

Shear resistance $V_{Rk} = V_{Rk,b} = V_{Rk,c,II} = V_{Rk,c,I}$ [kN] depending on the mean compressive strength f_b ; Installation and use condition w/w, w/d, d/d; (temperature range 50/80°C and 72/120°C)

Mean compressive strength / Min. compressive strength single brick ¹⁾	Use conditions	Effective anchorage depth h_{ef} [mm]											
		50	100	50	100	50	≥100	50	≥100	50	≥100	85	85
15 / 12 N/mm ²	w/w	1,5	3,0	1,5	3,0	1,2	2,0	1,2	2,0	1,2	2,0	1,2	1,2
	w/d	1,5	3,0	1,5	3,0	1,2	2,0	1,2	2,0	1,2	2,0	1,2	1,2
25 / 20 N/mm ²	w/w	2,5	4,0	2,5	4,0	1,5	3,0	1,5	3,0	1,5	3,0	1,5	1,5
	w/d	2,5	4,0	2,5	4,0	1,5	3,0	1,5	3,0	1,5	3,0	1,5	1,5
35 / 28 N/mm ²	w/w	3,0	4,5	3,0	4,5	1,5	3,5	1,5	3,5	1,5	3,5	1,5	1,5
	w/d	3,0	4,5	3,0	4,5	1,5	3,5	1,5	3,5	1,5	3,5	1,5	1,5

¹⁾ The compressive strength of the single brick must not be less than 80% of the mean compressive strength.

Factor for job site tests and displacements see annex C 123.

fischer injection system FIS V Plus for masonry

Performance

Solid calcium silicate brick KS, NF, Characteristic resistance under tension and shear loading

Annex C 15

Appendix 44 / 153

Solid calcium silicate brick KS, 8DF, EN 771-2:2011+A1:2015

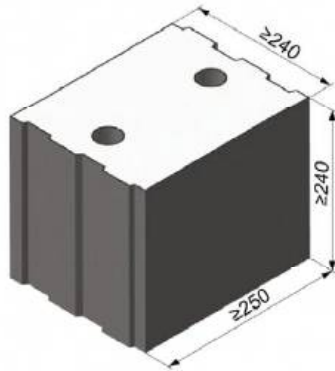

Producer		-		
Nominal dimensions	[mm]	length L	width W	height H
		≥ 250	≥ 240	≥ 240
Mean gross dry density ρ	[kg/dm ³]	≥ 2,0		
Mean compressive strength / Min. compressive strength single brick ¹⁾	[N/mm ²]	12,5 / 10 or 25 / 20 or 35 / 28		
Standard or annex		EN 771-2:2011+A1:2015		

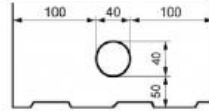

Dimension see also Annex B 15

Table C16.1: Installation parameters

Anchor rod	M6	M8	M10	M12	M16	-	-		
Internal threaded anchor FIS E	-	-	-	-	-	M6	M8	M10	M12
						11x85		15x85	

Anchor rod and internal threaded anchor FIS E without perforated sleeve

Effective anchorage depth h_{ef}	[mm]	50	100	50	100	50	100	50	100	50	100	85
Max. installation torque $max T_{inst}$	[Nm]	4		10						4	10	

Anchor rod and internal threaded anchor FIS E with perforated sleeve FIS H 16x85 K

Effective anchorage depth h_{ef}	[mm]	- ²⁾	85	- ²⁾	85	- ²⁾
Max. installation torque $max T_{inst}$	[Nm]		10		4	10

General installation parameters

Edge distance $c_{min} = c_{cr}$		60
Spacing	$s_{min \parallel}$	80
	$s_{cr \parallel}$	3x h_{ef}
	$s_{min \perp}$	80
	$s_{cr \perp}$	3x h_{ef}

Drilling method

Hammer drilling with hard metal hammer drill

- 1) The compressive strength of the single brick must not be less than 80% of the mean compressive strength
 2) No performance assessed

Table C16.2: Group factors

Anchor rods	M6	M8	M10	M12	M16	-	-		
Internal threaded anchor FIS E	-	-	-	-	-	M6	M8	M10	M12
						11x85		15x85	
Group factors	$\alpha_{a,N} (s_{min \parallel})$	[-]	1,5						
	$\alpha_{a,V} (s_{min \parallel})$		1,2						
	$\alpha_{a,N} (s_{min \perp})$		1,5						
	$\alpha_{a,V} (s_{min \perp})$		1,2						

fischer injection system FIS V Plus for masonry

Performance
 Solid calcium silicate brick KS, 8DF, dimensions, installation parameters

Annex C 16

Appendix 45 / 153

Solid calcium silicate brick KS, 8DF, EN 771-2:2011+A1:2015

Table C17.1: Characteristic resistance to pull-out failure or brick breakout failure of a single anchor under tension loading

Anchor rod		M6	M8	M10	M12	M16	-		-		M8	M10	-	
Internal threaded anchor FIS E		-	-	-	-	-	M6	M8	M10	M12	-	-	M6	M8
		11x85		15x85								11x85		
Perforated sleeve FIS H K		-	-	-	-	-	-		-		16x85			
Tension resistance $N_{Rk} = N_{Rk,p} = N_{Rk,b} = N_{Rk,p,c} = N_{Rk,b,c}$ [kN] depending on the mean compressive strength f_b ; Installation and use condition w/w, w/d, d/d; (temperature range 50/80°C) ²⁾														
Mean compressive strength / Min. compressive strength single brick ¹⁾	Use conditions	Effective anchorage depth h_{ef} [mm]												
		≥ 50					85							
12,5 / 10 N/mm ²	w/w	3,0	4,0	4,5	4,5	3,5	3,0	3,5		4,5	3,0	4,5		
	w/d	5,0	7,0	7,0	7,0	5,5	5,0	5,5		8,0	5,0	8,0		
25 / 20 N/mm ²	w/w	4,5	6,0	6,0	6,0	5,0	4,5	5,0		6,5	4,5	6,5		
	w/d	7,5	10,0	10,0	10,0	7,5	7,5	7,5		11,0	7,5	11		
35 / 28 N/mm ²	w/w	5,0	8,0	8,5	8,5	7,0	5,0	7,0		8,5	5,0	8,5		
	w/d	8,5	12,0	12,0	12,0	11,0	8,5	11,0		12,0	8,5	12		

¹⁾ The compressive strength of the single brick must not be less than 80% of the mean compressive strength.

²⁾ For temperature range 72/120°C: $N_{Rk(72/120°C)} = 0,83 \cdot N_{Rk(50/80°C)}$.

Table C17.2: Characteristic resistance to local brick failure or brick edge failure of a single anchor under shear loading

Anchor rod		M6	M8	M10	M12	M16	-		-		M8	M10	-	
Internal threaded anchor FIS E		-	-	-	-	-	M6	M8	M10	M12	-	-	M6	M8
		11x85		15x85								11x85		
Perforated sleeve FIS H K		-	-	-	-	-	-		-		16x85			
Shear resistance $V_{Rk} = V_{Rk,b} = V_{Rk,c,II} = V_{Rk,c,I}$ [kN] depending on the mean compressive strength f_b ; Installation and use condition w/w, w/d, d/d; (temperature range 50/80°C and 72/120°C)														
Mean compressive strength / Min. compressive strength single brick ¹⁾	Use conditions	Effective anchorage depth h_{ef} [mm]												
		≥ 50					85							
12,5 / 10 N/mm ²	w/w	2,5	4,5			2,5	4,5		4,5	2,5	4,5			
	w/d	4,0	6,5			4,0	6,5		6,5	4,0	6,5			
25 / 20 N/mm ²	w/w	5,0	9,0			5,0	9,0		9,0	5,0	9,0			
	w/d	8,5	12,0			8,5	12,0		12,0	8,5	12			

¹⁾ The compressive strength of the single brick must not be less than 80% of the mean compressive strength.

Factor for job site tests and displacements see annex C 123.

fischer injection system FIS V Plus for masonry

Performance

Solid calcium silicate brick KS, 8DF, Characteristic resistance under tension and shear loading

Annex C 17

Appendix 46 / 153

Solid calcium silicate brick KS, EN 771-2:2011+A1:2015

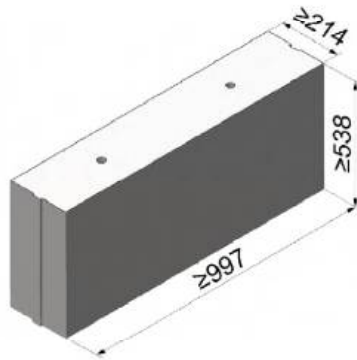

Producer		e.g. Calduran		
Nominal dimensions	[mm]	length L	width W	height H
		≥ 997	≥ 214	≥ 538
Mean gross dry density ρ	[kg/dm ³]	1,8		2,2
Mean compressive strength / Min. compressive strength single brick ¹⁾	[N/mm ²]	12,5 / 10 or 25 / 20		45 / 36
Standard or annex		EN 771-2:2011+A1:2015		



Table C18.1: Installation parameters

Anchor rod	M6	M8	M10	M12	M16	-	-			
Internal threaded anchor FIS E	-	-	-	-	-	M6	M8	M10	M12	
	11x85		15x85							
Anchor rod and internal threaded anchor FIS E without perforated sleeve										
Effective anchorage depth h_{ef}	[mm]	50	100	50	100	50	100	50	100	85
Max. installation torque $\max T_{inst}$	[Nm]	4		10				4	10	
General installation parameters										
Edge distance $c_{min} = c_{cr}$	[mm]	75								
Spacing	$s_{cr \parallel} = s_{min \parallel}$	3x h_{ef}								
	$s_{cr \perp} = s_{min \perp}$	3x h_{ef}								
Drilling method										
Hammer drilling with hard metal hammer drill										

¹⁾ The compressive strength of the single brick must not be less than 80% of the mean compressive strength.

Table C18.2: Group factors

Anchor rod	M6	M8	M10	M12	M16	-	-		
Internal threaded anchor FIS E	-	-	-	-	-	M6	M8	M10	M12
	11x85		15x85						
Group factors	$\alpha_{g,N} (s_{min \parallel})$	[-]	2						
	$\alpha_{g,V} (s_{min \parallel})$								
	$\alpha_{g,N} (s_{min \perp})$								
	$\alpha_{g,V} (s_{min \perp})$								

fischer injection system FIS V Plus for masonry

Performance
Solid calcium silicate brick KS, dimensions, installation parameters

Annex C 18

Appendix 47 / 153

Solid calcium silicate brick KS, EN 771-2:2011+A1:2015

Table C19.1: Characteristic resistance to pull-out failure or brick breakout failure of a single anchor under tension loading

Anchor rod		M6	M8	M10	M12	M16	-		-		
Internal threaded anchor FIS E		-	-	-	-	-	M6	M8	M10	M12	
								11x85		15x85	
Tension resistance $N_{Rk} = N_{Rk,p} = N_{Rk,b} = N_{Rk,p,c} = N_{Rk,b,c}$ [kN] depending on the mean compressive strength f_b ; Installation and use condition w/w, w/d, d/d; (temperature range 50/80°C) ²⁾											
Mean compressive strength / Min. compressive strength single brick ¹⁾	Use conditions	Effective anchorage depth h_{ef} [mm]									
		50	100	50	100	50	100	50	100	50	100
12,5 / 10 N/mm ²	w/w w/d	4,0	4,0	7,0	5,0	6,0	5,0	6,0	5,5	7,5	5,5
	d/d	7,0	7,0	12,0	8,0	9,5	8,0	10,0	9,0	11,5	9,0
25 / 20 N/mm ²	w/w w/d	5,5	6,0	10,0	7,0	8,5	7,0	9,0	8,0	11,0	8,0
	d/d	8,5	10,5	12,0	11,5	12,0	11,0	12,0	12,0	12,0	12,0
45 / 36 N/mm ²	w/w w/d	4,5	8,0	12,0	11,5	12,0	12,0	12,0	12,0	12,0	12,0
	d/d	8,0	12,0	12,0	12,0	12,0	12,0	12,0	12,0	12,0	12,0

¹⁾ The compressive strength of the single brick must not be less than 80% of the mean compressive strength.

²⁾ For temperature range 72/120°C: $N_{Rk(72/120°C)} = 0,83 \cdot N_{Rk(50/80°C)}$.

Table C19.2: Characteristic resistance to local brick failure or brick edge failure of a single anchor under shear loading

Anchor rod		M6	M8	M10	M12	M16	-		-		
Internal threaded anchor FIS E		-	-	-	-	-	M6	M8	M10	M12	
								11x85		15x85	
Shear resistance $V_{Rk} = V_{Rk,b} = V_{Rk,c,II} = V_{Rk,c,\perp}$ [kN] depending on the mean compressive strength f_b ; Installation and use condition w/w, w/d, d/d; (temperature range 50/80°C and 72/120°C)											
Mean compressive strength / Min. compressive strength single brick ¹⁾	Use conditions	Effective anchorage depth h_{ef} [mm]									
		≥ 50									
12,5 / 10 N/mm ²	w/w w/d	3,0	5,0	5,5	4,0	4,0	3,0	5,0	5,5	4,0	
	d/d										
25 / 20 N/mm ²	w/w w/d	4,5	7,0	7,5	6,0	6,0	4,5	7,0	7,5	6,0	
	d/d										
45 / 36 N/mm ²	w/w w/d	4,5	9,0	11,0	12,0	12,0	4,5	9,0	11,0	12,0	
	d/d										

¹⁾ The compressive strength of the single brick must not be less than 80% of the mean compressive strength.

Factor for job site tests and displacements see annex C 123.

fischer injection system FIS V Plus for masonry

Performance

Solid calcium silicate brick KS, Characteristic resistance under tension and shear loading

Annex C 19

Appendix 48 / 153

Solid calcium silicate brick KS, EN 771-2:2011+A1:2015

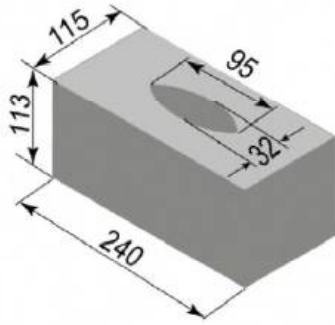

Producer	-			
Nominal dimensions	[mm]	length L	width W	height H
		≥ 240	≥ 115	≥ 113
Mean gross dry density ρ	[kg/dm ³]	1,8		
Mean compressive strength / Min. compressive strength single brick ¹⁾	[N/mm ²]	12,5 / 10 or 25 / 20		
Standard or annex	EN 771-2:2011+A1:2015			

Table C20.1: Installation parameters
(Pre-positioned anchorage with perforated sleeve FIS H K)

Anchor rod	M6	M8	-	M8	M10	M8	M10	-	M12	M16	M12	M16
Internal threaded anchor FIS E	-		M6	M8	-		-		M10	M12	-	
			11x85						15x85			
Perforated sleeve FIS H K	12x85		16x85		16x130		20x85		20x130			

Anchor rod and internal threaded anchor FIS E with perforated sleeve FIS H K

Max. installation torque	max T_{inst} [Nm]	2	4	
--------------------------	---------------------	---	---	--

General installation parameters

Edge distance	$c_{min} = c_{cr}$	100			
Spacing	$s_{min \parallel}$	255	255	390	255
	$s_{cr \parallel}$ [mm]				
	$s_{min \perp}$				
	$s_{cr \perp}$				
390					

Drilling method

Hammer drilling with hard metal hammer drill

¹⁾ The compressive strength of the single brick must not be less than 80% of the mean compressive strength.

Table C20.2: Group factors

Anchor rod	M6	M8	M8	M10	M8	M10	M12	M16	M12	M16
Perforated sleeve FIS H K	12x85		16x85		16x130		20x85		20x130	
Group factors	$\frac{\alpha_{g,N}(s_{min \parallel})}{\alpha_{g,V}(s_{min \parallel})} =$ $\frac{\alpha_{g,N}(s_{min \perp})}{\alpha_{g,V}(s_{min \perp})} =$		[-]		2					

fischer injection system FIS V Plus for masonry

Performance
Solid calcium silicate brick KS, dimensions, installation parameters

Annex C 20

Appendix 49 / 153

Solid calcium silicate brick KS, EN 771-2:2011+A1:2015

Table C21.1: Installation parameters
(Push through anchorage with perforated sleeve FIS H K)

Anchor rod		M10	M12	M16
Perforated sleeve FIS H K		18x130/200		22x130/200
Anchor rod with perforated sleeve FIS H K				
Max. installation torque	$\max T_{inst}$ [Nm]	4		
General installation parameters				
Edge distance	$c_{min} = c_{cr}$	100		
Spacing	$s_{min \parallel}$	390		
	$s_{cr \parallel}$ [mm]	390		
	$s_{min \perp}$	390		
	$s_{cr \perp}$	390		
Drilling method				
Hammer drilling with hard metal hammer drill				

Table C21.2: Group factors

Anchor rod		M10	M12	M16
Perforated sleeve FIS H K		18x130/200		22x130/200
Group factors	$\alpha_{g,N}(s_{min \parallel})$	[-]	2	
	$\alpha_{g,V}(s_{min \parallel})$			
	$\alpha_{g,N}(s_{min \perp})$			
	$\alpha_{g,V}(s_{min \perp})$			

fischer injection system FIS V Plus for masonry

Performance
Solid calcium silicate brick KS, dimensions, installation parameters

Annex C 21

Appendix 50 / 153

Solid calcium silicate brick, EN 771-2:2011+A1:2015

Table C22.1: Characteristic resistance to pull-out failure or brick breakout failure of a single anchor under tension loading (Pre-positioned anchorage)

Anchor rod	M6	M8	-	M8	M10	M8	M10	-	M12	M16	M12	M16
Internal threaded anchor FIS E	-		M6	M8	-		-		M10	M12	-	
			11x85						15x85			
Perforated sleeve FIS H K	12x85		16x85			16x130		20x85			20x130	

Tension resistance $N_{Rk} = N_{Rk,p} = N_{Rk,b} = N_{Rk,p,c} = N_{Rk,b,c}$ [kN] depending on the mean compressive strength f_b ; Installation and use condition w/w, d/d; (temperature range 50/80°C)²⁾

Mean compressive strength / Min. compressive strength single brick ¹⁾	Use conditions							
12,5 / 10 N/mm ²	w/w	3,5	2,0	2,0	2,0	6,5		4,5
	d/d	6,0	4,0	3,5	3,5	10,5		7,0
25 / 20 N/mm ²	w/w	5,0	3,0	3,0	3,0	9,5		6,0
	d/d	8,5	5,5	5,5	5,5	12,0		10,0

¹⁾ The compressive strength of the single brick must not be less than 80% of the mean compressive strength.

²⁾ For temperature range 72/120°C no performance assessed.

Table C22.2: Characteristic resistance to pull-out failure or brick breakout failure of a single anchor under tension loading (Push through anchorage)

Anchor rod	M10	M12	M16
Perforated sleeve FIS H K	18x130/200		22x130/200

Tension resistance $N_{Rk} = N_{Rk,p} = N_{Rk,b} = N_{Rk,p,c} = N_{Rk,b,c}$ [kN] depending on the mean compressive strength f_b ; Installation and use condition w/w, d/d; (temperature range 50/80°C)²⁾

Mean compressive strength / Min. compressive strength single brick ¹⁾	Use conditions		
12,5 / 10 N/mm ²	w/w	2,0	
	d/d	3,5	
25 / 20 N/mm ²	w/w	3,0	
	d/d	5,5	

¹⁾ The compressive strength of the single brick must not be less than 80% of the mean compressive strength.

²⁾ For temperature range 72/120°C no performance assessed.

Factor for job site tests and displacements see annex C 123.

fischer injection system FIS V Plus for masonry

Performance
Solid calcium silicate brick KS, Characteristic resistance under tension loading

Annex C 22

Appendix 51 / 153

Table C23.1: Characteristic resistance to local brick failure or brick edge failure of a single anchor under shear loading (Pre-positioned anchorage)

Anchor rod	M6	M8	-	M8	M10	M8	M10	-	M12	M16	M12	M16
Internal threaded anchor FIS E	-		M6	M8	-		-		M10	M12	-	
			11x85						15x85			
Perforated sleeve FIS H K	12x85		16x85			16x130		20x85			20x130	

Shear resistance $V_{Rk} = V_{Rk,b} = V_{Rk,c,II} = V_{Rk,c,\perp}$ [kN] depending on the mean compressive strength f_b ; Installation and use condition w/w, d/d; (temperature range 50/80°C)²⁾

Mean compressive strength / Min. compressive strength single brick ¹⁾	Use conditions												
12,5 / 10 N/mm ²	w/w	3,0										3,5	
	d/d												
25 / 20 N/mm ²	w/w	4,0										5,5	
	d/d												

¹⁾ The compressive strength of the single brick must not be less than 80% of the mean compressive strength.

²⁾ For temperature range 72/120°C no performance assessed.

Table C23.2: Characteristic resistance to local brick failure or brick edge failure of a single anchor under shear loading (Push through anchorage)

Anchor rod	M10	M12	M16
Perforated sleeve FIS H K	18x130/200		22x130/200

Shear resistance $V_{Rk} = V_{Rk,b} = V_{Rk,c,II} = V_{Rk,c,\perp}$ [kN] depending on the mean compressive strength f_b ; Installation and use condition w/w, d/d; (temperature range 50/80°C)²⁾

Mean compressive strength / Min. compressive strength single brick ¹⁾	Use conditions												
12,5 / 10 N/mm ²	w/w											3,5	
	d/d												
25 / 20 N/mm ²	w/w											5,5	
	d/d												

¹⁾ The compressive strength of the single brick must not be less than 80% of the mean compressive strength.

²⁾ For temperature range 72/120°C no performance assessed.

Factor for job site tests and displacements see annex C 123.

fischer injection system FIS V Plus for masonry

Performance
Solid calcium silicate brick KS, Characteristic resistance under shear loading

Annex C 23

Appendix 52 / 153

Perforated calcium silicate brick KSL, 3DF, EN 771-2:2011+A1:2015

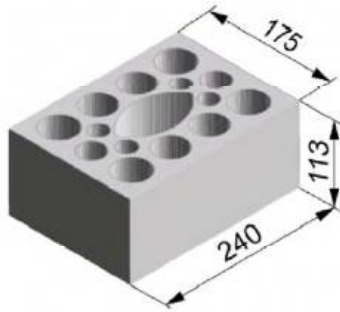

Producer		-		
Nominal dimensions	[mm]	length L	width W	height H
		240	175	113
Mean gross dry density ρ	[kg/dm ³]	$\geq 1,4$		
Mean compressive strength / Min. compressive strength single brick ¹⁾	[N/mm ²]	10 / 8 or 12,5 / 10 or 15 / 12 or 20 / 16 or 25 / 20		
Standard or annex		EN 771-2:2011+A1:2015		

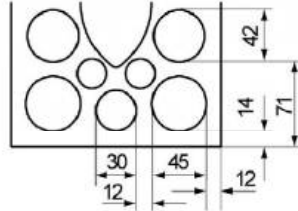

Dimension see also Annex B 15

Table C24.1: Installation parameters
(Pre-positioned anchorage with perforated sleeve FIS H K)

Anchor rod	M6	M8	M6	M8	-	M8	M10	M8	M10	-	M12	M16	M12	M16			
Internal threaded anchor FIS E	-		-		M6	M8	-		-		M10	M12	-				
					11x85						15x85						
Perforated sleeve FIS H K	12x50		12x85		16x85			16x130		20x85			20x130				
Anchor rod and internal threaded anchor FIS E with perforated sleeve FIS H K																	
Max. installation torque	max T _{inst}	[Nm]	2														
General installation parameters																	
Edge distance	C _{min} = C _{cr}		60				80										
Spacing	S _{min}	[mm]							100								
	S _{cr}								240								
	S _{min} ⊥								115								
	S _{cr} ⊥								115								
Drilling method																	
Hammer drilling with hard metal hammer drill																	

¹⁾ The compressive strength of the single brick must not be less than 80% of the mean compressive strength.

Table C24.2: Group factors

Anchor rod	M6	M8	M6	M8	-	M8	M10	M8	M10	-	M12	M16	M12	M16			
Internal threaded anchor FIS E	-		-		M6	M8	-		-		M10	M12	-				
					11x85						15x85						
Perforated sleeve FIS H K	12x50		12x85		16x85			16x130		20x85			20x130				
Group factors	$\alpha_{g,N} (S_{min}) =$	[-]							1,5								
	$\alpha_{g,V} (S_{min}) =$																
	$\alpha_{g,N} (S_{min} \perp) =$	[-]							2,0								
	$\alpha_{g,V} (S_{min} \perp) =$																

fischer injection system FIS V Plus for masonry

Performance

Perforated calcium silicate brick KSL, 3DF, dimensions, installation parameters

Annex C 24

Appendix 53 / 153

Perforated calcium silicate brick KSL, 3DF, EN 771-2:2011+A1:2015

Table C25.1: Installation parameters
(Push through anchorage with perforated sleeve FIS H K)

Anchor rod		M10	M12	M16
Perforated sleeve FIS H K		18x130/200		22x130/200
Anchor rod with perforated sleeve FIS H K				
Max. installation torque	max T _{inst} [Nm]	2		
General installation parameters				
Edge distance	c _{min} = c _{cr}	80		
Spacing	s _{min}	100		
	s _{cr} [mm]	240		
	s _{min} ⊥	115		
	s _{cr} ⊥	115		
Drilling method				
Hammer drilling with hard metal hammer drill				

Table C25.2: Group factors

Anchor rod		M10	M12	M16
Perforated sleeve FIS H K		18x130/200		22x130/200
Group factors	α _{g,N} (s _{min})	[-]	1,5	
	α _{g,V} (s _{min})			
	α _{g,N} (s _{min} ⊥)		2,0	
	α _{g,V} (s _{min} ⊥)			

fischer injection system FIS V Plus for masonry

Performance
Perforated calcium silicate brick KSL, 3DF, dimensions, installation parameters

Annex C 25

Appendix 54 / 153

Perforated calcium silicate brick KSL, 3DF, EN 771-2:2011+A1:2015

Table C26.1: Characteristic resistance to pull-out failure or brick breakout failure of a single anchor under tension loading (Pre-positioned anchorage)

Anchor rod	M6	M8	M6	M8	-	M8	M10	M8	M10	-	M12	M16	M12	M16
Internal threaded anchor FIS E	-		-		M6	M8	-		-		M10	M12	-	
					11x85						15x85			
Perforated sleeve FIS H K	12x50		12x85		16x85			16x130		20x85			20x130	

Tension resistance $N_{Rk} = N_{Rk,p} = N_{Rk,b} = N_{Rk,p,c} = N_{Rk,b,c}$ [kN] depending on the mean compressive strength f_b ; Installation and use condition w/w, w/d, d/d; (temperature range 50/80°C) ²⁾

Mean compressive strength / Min. compressive strength single brick ¹⁾	Use conditions									
	w/w	w/d								
10 / 8 N/mm ²	w/w	w/d	1,5		2,0		2,0		2,0	
	d/d		1,5		2,0		2,5		2,5	
12,5 / 10 N/mm ²	w/w	w/d	2,0		2,0		2,5		2,5	
	d/d		2,0		2,5		3,0		3,0	
15 / 12 N/mm ²	w/w	w/d	2,5		2,5		3,0		3,0	
	d/d		2,5		3,0		3,5		3,5	
20 / 16 N/mm ²	w/w	w/d	3,0		3,5		4,5		4,5	
	d/d		3,5		4,0		4,5		4,5	
25 / 20 N/mm ²	w/w	w/d	4,0		4,5		5,5		5,5	
	d/d		4,5		5,0		6,0		6,0	

¹⁾ The compressive strength of the single brick must not be less than 80% of the mean compressive strength.

²⁾ For temperature range 72/120°C: $N_{Rk(72/120°C)} = 0,83 \cdot N_{Rk(50/80°C)}$.

Table C26.2: Characteristic resistance to pull-out failure or brick breakout failure of a single anchor under tension loading (Push through anchorage)

Anchor rod	M10	M12	M16
Perforated sleeve FIS H K	18x130/200		22x130/200

Tension resistance $N_{Rk} = N_{Rk,p} = N_{Rk,b} = N_{Rk,p,c} = N_{Rk,b,c}$ [kN] depending on the mean compressive strength f_b ; Installation and use condition w/w, w/d, d/d; (temperature range 50/80°C) ²⁾

Mean compressive strength / Min. compressive strength single brick ¹⁾	Use conditions			
	w/w	w/d		
10 / 8 N/mm ²	w/w	w/d	2,0	
	d/d		2,5	
12,5 / 10 N/mm ²	w/w	w/d	2,5	
	d/d		3,0	
15 / 12 N/mm ²	w/w	w/d	3,0	
	d/d		3,5	
20 / 16 N/mm ²	w/w	w/d	4,5	
	d/d		4,5	
25 / 20 N/mm ²	w/w	w/d	5,5	
	d/d		6,0	

¹⁾ The compressive strength of the single brick must not be less than 80% of the mean compressive strength.

²⁾ For temperature range 72/120°C: $N_{Rk(72/120°C)} = 0,83 \cdot N_{Rk(50/80°C)}$.

Factor for job site tests and displacements see annex C 123.

fischer injection system FIS V Plus for masonry

Performance

Perforated calcium silicate brick KSL, 3DF, Characteristic resistance under tension loading

Annex C 26

Appendix 55 / 153

Perforated calcium silicate brick KSL, 3DF, EN 771-2:2011+A1:2015

Table C27.1: Characteristic resistance to local brick failure or brick edge failure of a single anchor under shear loading (Pre-positioned anchorage)

Anchor rod	M6	M8	M6	M8	-	M8	M10	M8	M10	-	M12	M16	M12	M16
Internal threaded anchor FIS E	-		-		M6	M8	-		-		M10	M12	-	
					11x85						15x85			
Perforated sleeve FIS H K	12x50		12x85		16x85			16x130		20x85			20x130	
Shear resistance $V_{Rk} = V_{Rk,b} = V_{Rk,c,II} = V_{Rk,c,\perp}$ [kN] depending on the mean compressive strength f_b ; Installation and use condition w/w, w/d, d/d; (temperature range 50/80°C and 72/120°C)														
Mean compressive strength / Min. compressive strength single brick ¹⁾	Use conditions													
10 / 8 N/mm ²	w/w	w/d	1,5						3,0			2,5	3,0	2,5
	d/d													
12,5 / 10 N/mm ²	w/w	w/d	2,0						3,5					
	d/d													
15 / 12 N/mm ²	w/w	w/d	2,5						4,5			4,0	4,5	4,0
	d/d													
20 / 16 N/mm ²	w/w	w/d	3,0	3,5	3,0	3,5	3,0	6,0			5,5	6,0	5,5	
	d/d													
25 / 20 N/mm ²	w/w	w/d	4,0	4,5	4,0	4,5	4,0	7,5			6,5	7,5	6,5	
	d/d													

¹⁾ The compressive strength of the single brick must not be less than 80% of the mean compressive strength.

Table C27.2: Characteristic resistance to local brick failure or brick edge failure of a single anchor under shear loading (Push through anchorage)

Anchor rod	M10	M12	M16
Perforated sleeve FIS H K	18x130/200		22x130/200
Shear resistance $V_{Rk} = V_{Rk,b} = V_{Rk,c,II} = V_{Rk,c,\perp}$ [kN] depending on the mean compressive strength f_b ; Installation and use condition w/w, w/d, d/d; (temperature range 50/80°C and 72/120°C)			
Mean compressive strength / Min. compressive strength single brick ¹⁾	Use conditions		
10 / 8 N/mm ²	w/w w/d d/d	3.0	
12,5 / 10 N/mm ²		3.5	
15 / 12 N/mm ²		4.5	
20 / 16 N/mm ²		6.0	
25 / 20 N/mm ²		7.5	

¹⁾ The compressive strength of the single brick must not be less than 80% of the mean compressive strength.

Factor for job site tests and displacements see annex C 123.

fischer injection system FIS V Plus for masonry

Performance
Perforated calcium silicate brick KSL, 3DF, Characteristic resistance under shear loading

Annex C 27

Appendix 56 / 153

Vertical perforated brick HLz, EN 771-1:2011+A1:2015

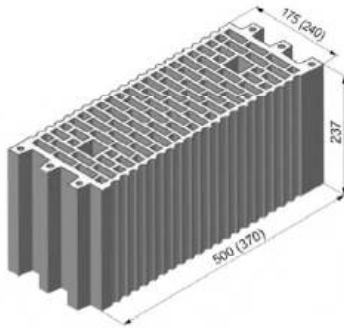

Producer		e.g. Wienerberger, Poroton		
Nominal dimensions	[mm]	length L	width W	height H
		500	175	237
		370	240	237
Mean gross dry density ρ	[kg/dm ³]	≥ 1,0		
Mean compressive strength / Min. compressive strength single brick ¹⁾	[N/mm ²]	5 / 4 or 7,5 / 6 or 10 / 8 or 12,5 / 10 or 15 / 12		
Standard or annex		EN 771-1:2011+A1:2015		

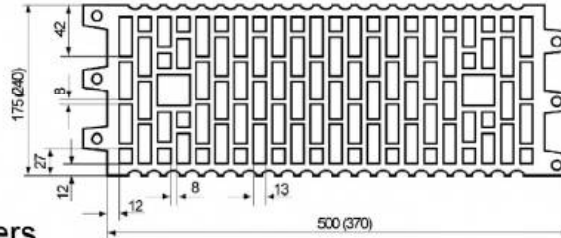

Dimension see also Annex B 15

Table C28.1: Installation parameters

Anchor rod	M6	M8	M6	M8	-	M8	M10	M8	M10	-	M12	M16	M12	M16
Internal threaded anchor FIS E	-	-	M6	M8		-	-	M10	M12		-	-		
			11x85					15x85						
Perforated sleeve FIS H K	12x50		12x85		16x85			16x130		20x85		20x130		
Anchor rod and internal threaded anchor FIS E with perforated sleeve FIS H K														
Max. installation torque	max T _{inst}	[Nm]	2											
General installation parameters														
Edge distance	C _{min} = C _{cr}		100											
Spacing	S _{min}		100											
	S _{cr}	[mm]	500 (370)											
	S _{min} ⊥		100											
	S _{cr} ⊥		240											

Drilling method

Hammer drilling with hard metal hammer drill

¹⁾ The compressive strength of the single brick must not be less than 80% of the mean compressive strength.

Table C28.2: Group factors

Anchor rod	M6	M8	M6	M8	-	M8	M10	M8	M10	-	M12	M16	M12	M16
Internal threaded anchor FIS E	-	-	M6	M8		-	-	M10	M12		-	-		
			11x85					15x85						
Perforated sleeve FIS H K	12x50		12x85		16x85			16x130		20x85		20x130		
Group factors	$\alpha_{g,N} (S_{min}) =$ $\alpha_{g,V} (S_{min})$ $\alpha_{g,N} (S_{min} \perp) =$ $\alpha_{g,V} (S_{min} \perp)$	[-]	1											

fischer injection system FIS V Plus for masonry

Performance

Vertical perforated brick HLz, dimensions, installation parameters

Annex C 28

Appendix 57 / 153

Vertical perforated brick HLz, EN 771-1:2011+A1:2015

Table C29.1: Characteristic resistance to pull-out failure or brick breakout failure of a single anchor under tension loading

Anchor rod	M6	M8	M6	M8	-	M8	M10	M8	M10	-	M12	M16	M12	M16
Internal threaded anchor FIS E	-	-	M6	M8	M6	M8	-	-	M10	M12	-	-	-	-
Perforated sleeve FIS H K	12x50	12x85	16x85		16x130		20x85		20x130					
Tension resistance $N_{Rk} = N_{Rk,p} = N_{Rk,b} = N_{Rk,p,c} = N_{Rk,b,c}$ [kN] depending on the mean compressive strength f_b ; Installation and use condition w/w, w/d, d/d; (temperature range 50/80°C) ²⁾														
Mean compressive strength / Min. compressive strength single brick ¹⁾	Use conditions													
5 / 4 N/mm ²	w/w	w/d	0,30		0,90		1,20							
	d/d		0,40		0,90		1,20							
7,5 / 6 N/mm ²	w/w	w/d	0,50		1,50		2,00							
	d/d		0,60		1,50		2,00							
10 / 8 N/mm ²	w/w	w/d	0,75		2,00		2,50							
	d/d		0,75		2,00		2,50							
12,5 / 10 N/mm ²	w/w	w/d	0,90		2,50		3,00							
	d/d		0,90		2,50		3,50							
15 / 12 N/mm ²	w/w	w/d	0,90		3,00		3,50							
	d/d		1,20		3,00		4,00							

¹⁾ The compressive strength of the single brick must not be less than 80% of the mean compressive strength.

²⁾ For temperature range 72/120°C: $N_{Rk(72/120^\circ C)} = 0,83 \cdot N_{Rk(50/80^\circ C)}$.

Table C29.2: Characteristic resistance to local brick failure or brick edge failure of a single anchor under shear loading

Anchor rod	M6	M8	M6	M8	-	M8	M10	M8	M10	-	M12	M16	M12	M16
Internal threaded anchor FIS E	-	-	M6	M8	M6	M8	-	-	M10	M12	-	-	-	-
Perforated sleeve FIS H K	12x50	12x85	16x85		16x130		20x85		20x130					
Shear resistance $V_{Rk} = V_{Rk,b} = V_{Rk,c,II} = V_{Rk,c,\perp}$ [kN] depending on the mean compressive strength f_b ; Installation and use condition w/w, w/d, d/d; (temperature range 50/80°C and 72/120°C)														
Mean compressive strength / Min. compressive strength single brick ¹⁾	Use conditions													
5 / 4 N/mm ²	w/w	w/d	0,50		0,60		0,50		0,60					
			0,75		0,90		0,75		0,90					
0,90			1,20		0,90		1,20							
1,20			1,50		1,20		1,50							
1,50			2,00		1,50		2,00							

¹⁾ The compressive strength of the single brick must not be less than 80% of the mean compressive strength.

Factor for job site tests and displacements see annex C 123.

fischer injection system FIS V Plus for masonry

Performance

Vertical perforated brick HLz, Characteristic resistance under tension and shear loading

Annex C 29

Appendix 58 / 153

Vertical perforated brick HLz, 2DF, EN 771-1:2011+A1:2015

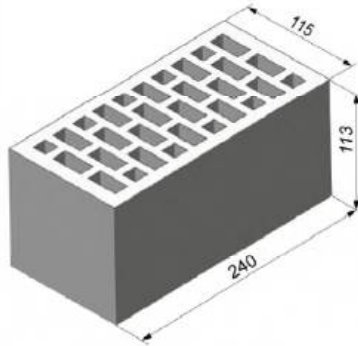

Producer	e.g. Wienerberger			
Nominal dimensions	[mm]	length L	width W	height H
		240	115	113
Mean gross dry density ρ	[kg/dm ³]	$\geq 1,4$		
Mean compressive strength / Min. compressive strength single brick ¹⁾	[N/mm ²]	7,5 / 6 or 12,5 / 10 or 20 / 16 or 25 / 20 or 35 / 28		
Standard or annex	EN 771-1:2011+A1:2015			

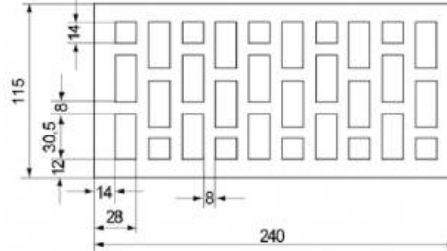

Dimension see also Annex B 15

Table C30.1: Installation parameters

Anchor rod	M6	M8	M6	M8	-	M8	M10	-	M12	M16
Internal threaded anchor FIS E	-		-		M6	M8	-		M10	M12
					11x85				15x85	
Perforated sleeve FIS H K	12x50		12x85		16x85			20x85		

Anchor rod and internal threaded anchor FIS E with perforated sleeve FIS H K

Max. installation torque $\max T_{inst}$ [Nm]	2									
---	---	--	--	--	--	--	--	--	--	--

General installation parameters

Edge distance $c_{min} = c_{cr}$	80									
Spacing $s_{cr \parallel} = s_{min \parallel}$	240									
	$s_{cr \perp} = s_{min \perp}$	115								

Drilling method

Hammer drilling with hard metal hammer drill

¹⁾ The compressive strength of the single brick must not be less than 80% of the mean compressive strength.

Table C30.2: Group factors

Anchor rod	M6	M8	M6	M8	-	M8	M10	-	M12	M16
Internal threaded anchor FIS E	-		-		M6	M8	-		M10	M12
					11x85				15x85	
Perforated sleeve FIS H K	12x50		12x85		16x85			20x85		

Group factors	$\alpha_{g,N} (s_{min \parallel})$	[-]	2							
	$\alpha_{g,V} (s_{min \parallel})$									
	$\alpha_{g,N} (s_{min \perp})$									
	$\alpha_{g,V} (s_{min \perp})$									

fischer injection system FIS V Plus for masonry

Performance
Vertical perforated brick HLz, 2DF, dimensions, installation parameters

Annex C 30

Appendix 59 / 153

Vertical perforated brick HLz, 2DF, EN 771-1:2011+A1:2015

Table C31.1: Characteristic resistance to pull-out failure or brick breakout failure of a single anchor under tension loading

Anchor rod	M6	M8	M6	M8	-	M8	M10	-	M12	M16
Internal threaded anchor FIS E	-	-	-	-	M6	M8	-	M10	M12	-
					11x85			15x85		
Perforated sleeve FIS H K	12x50		12x85		16x85			20x85		
Tension resistance $N_{Rk} = N_{Rk,p} = N_{Rk,b} = N_{Rk,p,c} = N_{Rk,b,c}$ [kN] depending on the mean compressive strength f_b ; Installation and use condition w/w, w/d, d/d; (temperature range 50/80°C) ²⁾										
Mean compressive strength / Min. compressive strength single brick ¹⁾	Use conditions									
7,5 / 6 N/mm ²	w/w	w/d	0,75	0,90	0,75			0,90		
	d/d		0,75	1,20	0,75			0,90		
12,5 / 10 N/mm ²	w/w	w/d	1,20	1,50	1,20			1,50		
	d/d		1,20	2,00	1,20			1,50		
20 / 16 N/mm ²	w/w	w/d	2,00	2,50	2,00			2,00		
	d/d		2,00	3,00	2,00			2,50		
25 / 20 N/mm ²	w/w	w/d	2,50	3,50	2,50			3,00		
	d/d		2,50	4,00	2,50			3,00		
35 / 28 N/mm ²	w/w	w/d	3,00	5,00	3,50			4,00		
	d/d		3,50	5,50	3,50			4,50		

¹⁾ The compressive strength of the single brick must not be less than 80% of the mean compressive strength.

²⁾ For temperature range 72/120°C: $N_{Rk(72/120^\circ C)} = 0,83 \cdot N_{Rk(50/80^\circ C)}$.

Table C31.2: Characteristic resistance to local brick failure or brick edge failure of a single anchor under shear loading

Anchor rod	M6	M8	M6	M8	-	M8	M10	-	M12	M16
Internal threaded anchor FIS E	-	-	-	-	M6	M8	-	M10	M12	-
					11x85			15x85		
Perforated sleeve FIS H K	12x50		12x85		16x85			20x85		
Shear resistance $V_{Rk} = V_{Rk,b} = V_{Rk,c,II} = V_{Rk,c,I}$ [kN] depending on the mean compressive strength f_b ; Installation and use condition w/w, w/d, d/d; (temperature range 50/80°C and 72/120°C)										
Mean compressive strength / Min. compressive strength single brick ¹⁾	Use conditions									
7,5 / 6 N/mm ²	w/w w/d d/d	1,2	1,5	1,2	2,0	1,2	1,5	2,5		
12,5 / 10 N/mm ²		2,0	2,5	2,0	4,0	2,0	2,5	4,5		
20 / 16 N/mm ²		3,0	3,5	3,0	6,0	3,0	3,5	7,0		
25 / 20 N/mm ²		4,0	4,5	4,0	7,5	4,0	4,5	8,5		
35 / 28 N/mm ²		5,0	6,5	5,0	9,5	5,0	6,5	12,0		

¹⁾ The compressive strength of the single brick must not be less than 80% of the mean compressive strength.

Factor for job site tests and displacements see annex C 123.

fischer injection system FIS V Plus for masonry

Performance

Vertical perforated brick HLz, 2DF,
Characteristic resistance under tension and shear loading

Annex C 31

Appendix 60 / 153

Vertical perforated brick HLz, U8, EN 771-1:2011+A1:2015

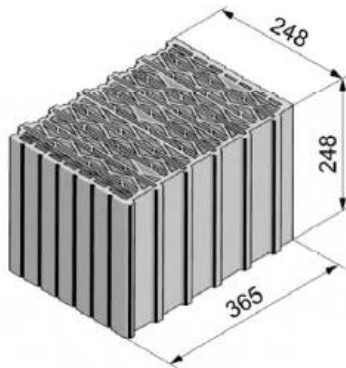

Producer		e.g. Wienerberger		
Nominal dimensions	[mm]	length L	width W	height H
		248	365	248
Mean gross dry density ρ	[kg/dm ³]	0,6		
Mean compressive strength / Min. compressive strength single brick ¹⁾	[N/mm ²]	5 / 4 or 7,5 / 6 or 10 / 8		
Standard or annex		EN 771-1:2011+A1:2015		

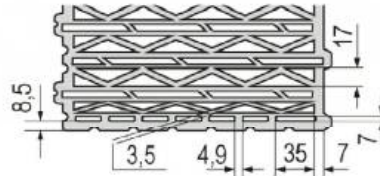

Dimension see also Annex B 15

Table C32.1: Installation parameters
(Pre-positioned anchorage with perforated sleeve FIS H K)

Anchor rod	M6	M8	M6	M8	-	M8	M10	M8	M10	-	M12	M16	M12	M16	M12	M16
Internal threaded anchor FIS E	-	-	-	-	M6	M8	-	-	-	M10	M12	-	-	-	-	-
					11x85					15x85						
Perforated sleeve FIS H K	12x50		12x85		16x85			16x130		20x85			20x130		20x200	

Anchor rod and internal threaded anchor FIS E with perforated sleeve FIS H K

Max. installation torque $\max T_{inst}$ [Nm]	3	5	3	5	3	5	5									
---	---	---	---	---	---	---	---	--	--	--	--	--	--	--	--	--

General installation parameters

Edge distance $C_{min} = C_{cr}$							60										
Spacing	$S_{min \parallel}$							80									
	$S_{cr \parallel}$ [mm]							250									
	$S_{min \perp}$							80									
	$S_{cr \perp}$							250									

Drilling method

Rotary drilling with carbide drill

¹⁾ The compressive strength of the single brick must not be less than 80% of the mean compressive strength.

Table C32.2: Group factors

Anchor rod	M6	M8	M6	M8	-	M8	M10	M8	M10	-	M12	M16	M12	M16	M12	M16
Internal threaded anchor FIS E	-	-	-	-	M6	M8	-	-	-	M10	M12	-	-	-	-	-
					11x85					15x85						
Perforated sleeve FIS H K	12x50		12x85		16x85			16x130		20x85			20x130		20x200	

Group factors	$\alpha_{g,N} (S_{min \parallel})$	[-]	1,3													
	$\alpha_{g,V} (S_{min \parallel})$		1,2													
	$\alpha_{g,N} (S_{min \perp})$		1,3													
	$\alpha_{g,V} (S_{min \perp})$		1,0													

fischer injection system FIS V Plus for masonry

Performance
Vertical perforated brick HLz, U8, dimensions, installation parameters

Annex C 32

Appendix 61 / 153

Vertical perforated brick HLz, U8, EN 771-1:2011+A1:2015

Table C33.1: Installation parameters
(Push through anchorage with perforated sleeve FIS H K)

Anchor rod		M10	M12	M16
Perforated sleeve FIS H K		18x130/200		22x130/200
Anchor rod with perforated sleeve FIS H K				
Max. installation torque	max T _{inst} [Nm]	5		
General installation parameters				
Edge distance	c _{min} = c _{cr}	60		
Spacing	s _{min}	80		
	s _{cr} [mm]	250		
	s _{min} ⊥	80		
	s _{cr} ⊥	250		
Drilling method				
Rotary drilling with carbide drill				

Table C33.2: Group factors

Anchor rod		M10	M12	M16
Perforated sleeve FIS H K		18x130/200		22x130/200
Group factors	α _{g,N} (s _{min})	1,3		
	α _{g,V} (s _{min})	1,2		
	α _{g,N} (s _{min} ⊥)	1,3		
	α _{g,V} (s _{min} ⊥)	1,0		

fischer injection system FIS V Plus for masonry

Performance
Vertical perforated brick HLz, U8, dimensions, installation parameters

Annex C 33

Appendix 62 / 153

Vertical perforated brick HLz, U8, EN 771-1:2011+A1:2015

Table C34.1: Characteristic resistance to pull-out failure or brick breakout failure of a single anchor under tension loading (Pre-positioned anchorage)

Anchor rod	M6	M8	M6	M8	-	M8	M10	M8	M10	-	M12	M16	M12	M16	M12	M16
Internal threaded anchor FIS E	-	-	M6	M8	-	-	-	-	M10	M12	-	-	-	-	-	-
Perforated sleeve FIS H K	12x50	12x85	16x85		16x130		20x85		20x130		20x200					
Tension resistance $N_{Rk} = N_{Rk,p} = N_{Rk,b} = N_{Rk,p,c} = N_{Rk,b,c}$ [kN] depending on the mean compressive strength f_b ; Installation and use condition w/w, w/d, d/d; (temperature range 50/80°C) ²⁾																
Mean compressive strength / Min. compressive strength single brick ¹⁾	Use conditions															
5 / 4 N/mm ²	w/w	w/d	1,2													1,2
	d/d		1,2													1,5
8 / 6 N/mm ²	w/w	w/d	1,5													1,5
	d/d		1,5													1,5
10 / 8 N/mm ²	w/w	w/d	1,5													2,0
	d/d		2,0													2,0

¹⁾ The compressive strength of the single brick must not be less than 80% of the mean compressive strength.

²⁾ For temperature range 72/120°C: $N_{Rk(72/120^\circ C)} = 0,83 \cdot N_{Rk(50/80^\circ C)}$.

Table C34.2: Characteristic resistance to pull-out failure or brick breakout failure of a single anchor under tension loading (Push through anchorage)

Anchor rod	M10		M12		M16		
Perforated sleeve FIS H K	18x130/200				22x130/200		
Tension resistance $N_{Rk} = N_{Rk,p} = N_{Rk,b} = N_{Rk,p,c} = N_{Rk,b,c}$ [kN] depending on the mean compressive strength f_b ; Installation and use condition w/w, w/d, d/d; (temperature range 50/80°C) ²⁾							
Mean compressive strength / Min. compressive strength single brick ¹⁾	Use conditions						
5 / 4 N/mm ²	w/w	w/d					1,2
	d/d						1,5
8 / 6 N/mm ²	w/w	w/d					1,5
	d/d						1,5
10 / 8 N/mm ²	w/w	w/d					2,0
	d/d						2,0

¹⁾ The compressive strength of the single brick must not be less than 80% of the mean compressive strength.

²⁾ For temperature range 72/120°C: $N_{Rk(72/120^\circ C)} = 0,83 \cdot N_{Rk(50/80^\circ C)}$.

Factor for job site tests and displacements see annex C 123.

fischer injection system FIS V Plus for masonry

Performance

Vertical perforated brick HLz, U8, Characteristic resistance under tension loading

Annex C 34

Appendix 63 / 153

Vertical perforated brick HLz, U8, EN 771-1:2011+A1:2015

Table C35.1: Characteristic resistance to local brick failure or brick edge failure of a single anchor under shear loading (Pre-positioned anchorage)

Anchor rod	M6	M8	M6	M8	-	M8	M10	M8	M10	-	M12	M16	M12	M16	M12	M16
Internal threaded anchor FIS E	-	-	M6	M8				-	M10	M12			-			
			11x85						15x85							
Perforated sleeve FIS H K	12x50	12x85	16x85	16x130	20x85	20x130	20x200									
Shear resistance $V_{Rk} = V_{Rk,b} = V_{Rk,c,II} = V_{Rk,c,\perp}$ [kN] depending on the mean compressive strength f_b ; Installation and use condition w/w, w/d, d/d; (temperature range 50/80°C and 72/120°C)																
Mean compressive strength / Min. compressive strength single brick ¹⁾	Use conditions															
5 / 4 N/mm ²	w/w	w/d	1,2													
	d/d															
8 / 6 N/mm ²	w/w	w/d	1,5													
	d/d															
10 / 8 N/mm ²	w/w	w/d	1,5													
	d/d															

¹⁾ The compressive strength of the single brick must not be less than 80% of the mean compressive strength.

Table C35.2: Characteristic resistance to local brick failure or brick edge failure of a single anchor under shear loading (Push through anchorage)

Anchor rod	M10		M12		M16	
Perforated sleeve FIS H K	18x130/200				22x130/200	
Shear resistance $V_{Rk} = V_{Rk,b} = V_{Rk,c,II} = V_{Rk,c,\perp}$ [kN] depending on the mean compressive strength f_b ; Installation and use condition w/w, w/d, d/d; (temperature range 50/80°C and 72/120°C)						
Mean compressive strength / Min. compressive strength single brick ¹⁾	Use conditions					
5 / 4 N/mm ²	w/w	w/d	1,2			
	d/d					
8 / 6 N/mm ²	w/w	w/d	1,5			
	d/d					
10 / 8 N/mm ²	w/w	w/d	1,5			
	d/d					

¹⁾ The compressive strength of the single brick must not be less than 80% of the mean compressive strength. Factor for job site tests and displacements see annex C 123.

fischer injection system FIS V Plus for masonry

Performance

Vertical perforated brick HLz, U8, Characteristic resistance under shear loading

Annex C 35

Appendix 64 / 153

Vertical perforated brick HLz, T10, T11, EN 771-1:2011+A1:2015

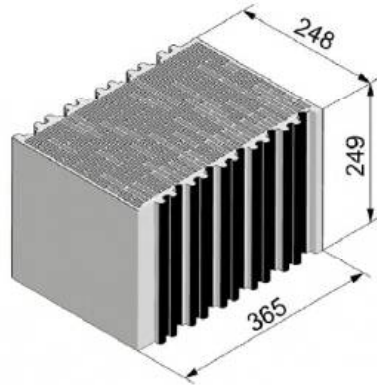

Producer	e.g. Wienerberger			
Nominal dimensions	[mm]	length L	width W	height H
		248	365	249
Mean gross dry density ρ	[kg/dm ³]	0,7		
Mean compressive strength / Min. compressive strength single brick ¹⁾	[N/mm ²]	10 / 8 or 12,5 / 10 or 15 / 12		
Standard or annex	EN 771-1:2011+A1:2015			

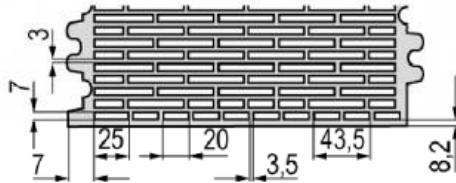

Dimension see also Annex B 16

Table C36.1: Installation parameters
(Pre-positioned anchorage with perforated sleeve FIS H K)

Anchor rod	M6	M8	M6	M8	-	M8	M10	M8	M10	-	M12	M16	M12	M16	M12	M16
Internal threaded anchor FIS E	-	-	M6 M8		-		-		M10 M12		-		-		-	
			11x85						15x85							
Perforated sleeve FIS H K	12x50		12x85		16x85			16x130		20x85			20x130		20x200	

Anchor rod and internal threaded anchor FIS E with perforated sleeve FIS H K

Max. installation torque	max T_{inst} [Nm]	3			5	3	5				
--------------------------	---------------------	---	--	--	---	---	---	--	--	--	--

General installation parameters

Edge distance	$c_{min} = c_{or}$	60				
	$s_{min \parallel}$	80				
	$s_{cr \parallel}$ [mm]	250				
	$s_{min \perp}$	80				
	$s_{cr \perp}$	250				

Drilling method

Rotary drilling with carbide drill

¹⁾ The compressive strength of the single brick must not be less than 80% of the mean compressive strength.

Table C36.2: Group factors

Anchor rod	M6	M8	M6	M8	-	M8	M10	M8	M10	-	M12	M16	M12	M16	M12	M16
Internal threaded anchor FIS E	-	-	M6 M8		-		-		M10 M12		-		-		-	
			11x85						15x85							
Perforated sleeve FIS H K	12x50		12x85		16x85			16x130		20x85			20x130		20x200	

Group factors	$\alpha_{g,N} (s_{min \parallel})$	[-]	1,7				
	$\alpha_{g,V} (s_{min \parallel})$		0,5				
	$\alpha_{g,N} (s_{min \perp})$		1,3				
	$\alpha_{g,V} (s_{min \perp})$		0,5				

fischer injection system FIS V Plus for masonry

Performance
Vertical perforated brick HLz, T10, T11, dimensions, installation parameters

Annex C 36

Appendix 65 / 153

Vertical perforated brick HLz, T10, T11, EN 771-1:2011+A1:2015

Table C37.1: Installation parameters
(Push through anchorage with perforated sleeve FIS H K)

Anchor rod		M10	M12	M16
Perforated sleeve FIS H K		18x130/200		22x130/200
Anchor rod with perforated sleeve FIS H K				
Max. installation torque	$\max T_{inst}$ [Nm]	5		
General installation parameters				
Edge distance	$c_{min} = c_{cr}$	60		
Spacing	$s_{min \parallel}$	80		
	$s_{cr \parallel}$ [mm]	250		
	$s_{min \perp}$	80		
	$s_{cr \perp}$	250		
	Drilling method			
Rotary drilling with carbide drill				

Table C37.2: Group factors

Anchor rod		M10	M12	M16
Perforated sleeve FIS H K		18x130/200		22x130/200
Group factors	$\alpha_{g,N}(s_{min \parallel})$	[-]	1,7	
	$\alpha_{g,V}(s_{min \parallel})$		0,5	
	$\alpha_{g,N}(s_{min \perp})$		1,3	
	$\alpha_{g,V}(s_{min \perp})$		0,5	

fischer injection system FIS V Plus for masonry

Performance

Vertical perforated brick HLz, T10, T11, dimensions, installation parameters

Annex C 37

Appendix 66 / 153

Vertical perforated brick HLz, T10, T11, EN 771-1:2011+A1:2015

Table C38.1: Characteristic resistance to pull-out failure or brick breakout failure of a single anchor under tension loading (Pre-positioned anchorage)

Anchor rod	M6	M8	M6	M8	-	M8	M10	M8	M10	-	M12	M16	M12	M16	M12	M16
Internal threaded anchor FIS E	-		-		M6	M8	-		-		M10	M12	-		-	
Perforated sleeve FIS H K	12x50		12x85		16x85		16x130		20x85		20x130		20x200			

Tension resistance $N_{Rk} = N_{Rk,p} = N_{Rk,b} = N_{Rk,p,c} = N_{Rk,b,c}$ [kN] depending on the mean compressive strength f_b ; Installation and use condition w/w, w/d, d/d; (temperature range 50/80°C)²⁾

Mean compressive strength / Min. compressive strength single brick ¹⁾	Use conditions																	
	10 / 8 N/mm ²	w/w	w/d	1,5														1,5
d/d			1,5														2,0	
12,5 / 10 N/mm ²	w/w	w/d	1,5														2,0	
	d/d		2,0														2,0	
15 / 12 N/mm ²	w/w	w/d	2,0														2,0	
	d/d		2,0														2,5	

¹⁾ The compressive strength of the single brick must not be less than 80% of the mean compressive strength.

²⁾ For temperature range 72/120°C: $N_{Rk(72/120^\circ C)} = 0,83 \cdot N_{Rk(50/80^\circ C)}$.

Table C38.2: Characteristic resistance to pull-out failure or brick breakout failure of a single anchor under tension loading (Push through anchorage)

Anchor rod	M10	M12	M16
Perforated sleeve FIS H K	18x130/200		22x130/200

Tension resistance $N_{Rk} = N_{Rk,p} = N_{Rk,b} = N_{Rk,p,c} = N_{Rk,b,c}$ [kN] depending on the mean compressive strength f_b ; Installation and use condition w/w, w/d, d/d; (temperature range 50/80°C)²⁾

Mean compressive strength / Min. compressive strength single brick ¹⁾	Use conditions																	
	10 / 8 N/mm ²	w/w	w/d	1,5														1,5
d/d			2,0														2,0	
12,5 / 10 N/mm ²	w/w	w/d	2,0														2,0	
	d/d		2,0														2,0	
15 / 12 N/mm ²	w/w	w/d	2,0														2,0	
	d/d		2,5														2,5	

¹⁾ The compressive strength of the single brick must not be less than 80% of the mean compressive strength.

²⁾ For temperature range 72/120°C: $N_{Rk(72/120^\circ C)} = 0,83 \cdot N_{Rk(50/80^\circ C)}$.

Factor for job site tests and displacements see annex C 123.

fischer injection system FIS V Plus for masonry

Performance
Vertical perforated brick HLz, T10, T11, Characteristic resistance under tension loading

Annex C 38

Appendix 67 / 153

Vertical perforated brick HLz, T10, T11, EN 771-1:2011+A1:2015

Table C39.1: Characteristic resistance to local brick failure or brick edge failure of a single anchor under shear loading (Pre-positioned anchorage)

Anchor rod	M6	M8	M6	M8	-	M8	M10	M8	M10	-	M12	M16	M12	M16	M12	M16
Internal threaded anchor FIS E	-		-		M6	M8	-		-		M10	M12	-		-	
Perforated sleeve FIS H K	12x50		12x85		16x85			16x130			20x85		20x130		20x200	
Shear resistance $V_{Rk} = V_{Rk,b} = V_{Rk,c,II} = V_{Rk,c,I}$ [kN] depending on the mean compressive strength f_b ; Installation and use condition w/w, w/d, d/d; (temperature range 50/80°C and 72/120°C)																
Mean compressive strength / Min. compressive strength single brick ¹⁾		Use conditions														
10 / 8 N/mm ²		w/w	w/d	0,9				1,5				2,0				
		d/d														
12,5 / 10 N/mm ²		w/w	w/d	0,9				1,5				2,0				
		d/d														
15 / 12 N/mm ²		w/w	w/d	1,2				2,0				2,0				
		d/d														

¹⁾ The compressive strength of the single brick must not be less than 80% of the mean compressive strength.

Table C39.2: Characteristic resistance to local brick failure or brick edge failure of a single anchor under shear loading (Push through anchorage)

Anchor rod	M10		M12		M16	
Perforated sleeve FIS H K	18x130/200				22x130/200	
Shear resistance $V_{Rk} = V_{Rk,b} = V_{Rk,c,II} = V_{Rk,c,I}$ [kN] depending on the mean compressive strength f_b ; Installation and use condition w/w, w/d, d/d; (temperature range 50/80°C and 72/120°C)						
Mean compressive strength / Min. compressive strength single brick ¹⁾		Use conditions				
10 / 8 N/mm ²		w/w	w/d	1,5		2,0
		d/d				
12,5 / 10 N/mm ²		w/w	w/d	1,5		2,0
		d/d				
15 / 12 N/mm ²		w/w	w/d	2,0		2,0
		d/d				

¹⁾ The compressive strength of the single brick must not be less than 80% of the mean compressive strength.

Factor for job site tests and displacements see annex C 123.

fischer injection system FIS V Plus for masonry

Performance
Vertical perforated brick HLz, T10, T11, Characteristic resistance under shear loading

Annex C 39

Appendix 68 / 153

Vertical perforated brick HLz, T7 PF, filled with perlit, EN 771-1:2011+A1:2015

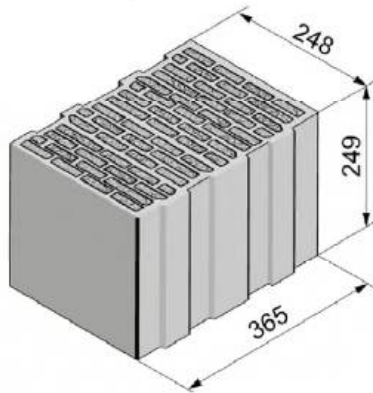

Producer	e.g. Wienerberger			
Nominal dimensions	[mm]	length L	width W	height H
		248	365	249
Mean gross dry density ρ	[kg/dm ³]	0,5		
Mean compressive strength / Min. compressive strength single brick ¹⁾	[N/mm ²]	5 / 4 or 8 / 6		
Standard or annex	EN 771-1:2011+A1:2015			

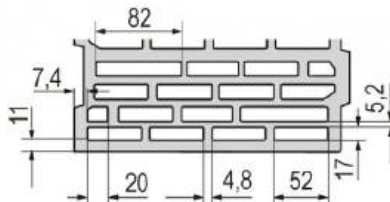

Dimension see also Annex B 16

Table C40.1: Installation parameters (Pre-positioned anchorage with perforated sleeve FIS H K)

Anchor rod	M6	M8	M6	M8	-	M8	M10	M8	M10	-	M12	M16	M12	M16	M12	M16
Internal threaded anchor FIS E	-		-		M6	M8	-		-		M10	M12	-		-	
					11x85						15x85					
Perforated sleeve FIS H K	12x50		12x85		16x85				16x130		20x85			20x130		20x200

Anchor rod and internal threaded anchor FIS E with perforated sleeve FIS H K

Max. installation torque $\max T_{inst}$ [Nm]	2				5		2		5						
---	---	--	--	--	---	--	---	--	---	--	--	--	--	--	--

General installation parameters

Edge distance $c_{min} = c_{cr}$	60															
Spacing	$s_{min \parallel}$	80														
	$s_{cr \parallel}$ [mm]	250														
	$s_{min \perp}$	80														
	$s_{cr \perp}$	250														

Drilling method

Rotary drilling with carbide drill

¹⁾ The compressive strength of the single brick must not be less than 80% of the mean compressive strength.

Table C40.2: Group factors

Anchor rod	M6	M8	M6	M8	-	M8	M10	M8	M10	-	M12	M16	M12	M16	M12	M16
Internal threaded anchor FIS E	-		-		M6	M8	-		-		M10	M12	-		-	
					11x85						15x85					
Perforated sleeve FIS H K	12x50		12x85		16x85				16x130		20x85			20x130		20x200
Group factors	$\alpha_{g,N} (s_{min \parallel})$	1,1														
	$\alpha_{g,V} (s_{min \parallel})$	1,2														
	$\alpha_{g,N} (s_{min \perp})$	1,1														
	$\alpha_{g,V} (s_{min \perp})$	1,2														

fischer injection system FIS V Plus for masonry

Performance
Vertical perforated brick HLz, T7 PF, filled with perlite, dimensions, installation parameters

Annex C 40

Appendix 69 / 153

Vertical perforated brick HLz, T7 PF, filled with perlite, EN 771-1:2011+A1:2015

Table C41.1: Installation parameters
(Push through anchorage with perforated sleeve FIS H K)

Anchor rod		M10	M12	M16
Perforated sleeve FIS H K		18x130/200		22x130/200
Anchor rod with perforated sleeve FIS H K				
Max. installation torque	max T _{inst} [Nm]	5		
General installation parameters				
Edge distance	c _{min} = c _{cr}	60		
Spacing	s _{min}	80		
	s _{cr} [mm]	250		
	s _{min} ⊥	80		
	s _{cr} ⊥	250		
Drilling method				
Rotary drilling with carbide drill				

Table C41.2: Group factors

Anchor rod		M10	M12	M16
Perforated sleeve FIS H K		18x130/200		22x130/200
Group factors	α _{g,N} (s _{min})	1,1		
	α _{g,V} (s _{min})	1,2		
	α _{g,N} (s _{min} ⊥)	1,1		
	α _{g,V} (s _{min} ⊥)	1,2		

fischer injection system FIS V Plus for masonry

Performance
Vertical perforated brick HLz, T7 PF, filled with perlite,
dimensions, installation parameters

Annex C 41

Appendix 70 / 153

Vertical perforated brick HLz, T7 PF, filled with perlite, EN 771-1:2011+A1:2015
Table C42.1: Characteristic resistance to pull-out failure or brick breakout failure of a single anchor under tension loading (Pre-positioned anchorage)

Anchor rod	M6	M8	M6	M8	-	M8	M10	M8	M10	-	M12	M16	M12	M16	M12	M16
Internal threaded anchor FIS E	-		-		M6	M8	-		-		M10	M12	-		-	
					11x85						15x85					
Perforated sleeve FIS H K	12x50		12x85		16x85			16x130		20x85			20x130		20x200	
Tension resistance $N_{Rk} = N_{Rk,p} = N_{Rk,b} = N_{Rk,p,c} = N_{Rk,b,c}$ [kN] depending on the mean compressive strength f_b ; Installation and use condition w/w, w/d, d/d; (temperature range 50/80°C) ²⁾																
Mean compressive strength / Min. compressive strength single brick ¹⁾		Use conditions														
5 / 4 N/mm ²		w/w	w/d	1,2				1,2		1,2			1,2		2,0	
		d/d		1,5				1,5		1,5			1,5		2,0	
8 / 6 N/mm ²		w/w	w/d	1,5				1,5		1,5			1,5		2,5	
		d/d		1,5				2,0		1,5			2,0		3,0	

¹⁾ The compressive strength of the single brick must not be less than 80% of the mean compressive strength.

²⁾ For temperature range 72/120°C: $N_{Rk(72/120^\circ C)} = 0,83 \cdot N_{Rk(50/80^\circ C)}$.

Table C42.2: Characteristic resistance to pull-out failure or brick breakout failure of a single anchor under tension loading (Push through anchorage)

Anchor rod	M10		M12		M16	
Perforated sleeve FIS H K	18x130/200				22x130/200	
Tension resistance $N_{Rk} = N_{Rk,p} = N_{Rk,b} = N_{Rk,p,c} = N_{Rk,b,c}$ [kN] depending on the mean compressive strength f_b ; Installation and use condition w/w, w/d, d/d; (temperature range 50/80°C) ²⁾						
Mean compressive strength / Min. compressive strength single brick ¹⁾		Use conditions				
5 / 4 N/mm ²		w/w	w/d	1,2		1,2
		d/d		1,5		1,5
8 / 6 N/mm ²		w/w	w/d	1,5		1,5
		d/d		2,0		2,0

¹⁾ The compressive strength of the single brick must not be less than 80% of the mean compressive strength.

²⁾ For temperature range 72/120°C: $N_{Rk(72/120^\circ C)} = 0,83 \cdot N_{Rk(50/80^\circ C)}$.

Factor for job site tests and displacements see annex C 123.

fischer injection system FIS V Plus for masonry

Performance

 Vertical perforated brick HLz, T7 PF, filled with perlite,
 Characteristic resistance under tension loading

Annex C 42

Appendix 71 / 153

Vertical perforated brick HLz, T7 PF, filled with perlite, EN 771-1:2011+A1:2015
Table C43.1: Characteristic resistance to local brick failure or brick edge failure of a single anchor under shear loading (Pre-positioned anchorage)

Anchor rod	M6	M8	M6	M8	-		M8	M10	M8	M10	-		M12	M16	M12	M16	M12	M16
Internal threaded anchor FIS E	-		-		M6	M8			-		M10	M12	-			-		
Perforated sleeve FIS H K	12x50	12x85			16x85				16x130				20x85			20x130		20x200

Shear resistance $V_{Rk} = V_{Rk,b} = V_{Rk,c,II} = V_{Rk,c,I}$ [kN] depending on the mean compressive strength f_b ; Installation and use condition w/w, w/d, d/d; (temperature range 50/80°C and 72/120°C)

Mean compressive strength / Min. compressive strength single brick ¹⁾	Use conditions				
	w/w	w/d			
5 / 4 N/mm ²	d/d		0,9	1,5	1,2
	w/w	w/d			
8 / 6 N/mm ²	d/d		1,2	2,0	1,5
	w/w	w/d			

¹⁾ The compressive strength of the single brick must not be less than 80% of the mean compressive strength.

Table C43.2: Characteristic resistance to local brick failure or brick edge failure of a single anchor under shear loading (Push through anchorage)

Anchor rod	M10	M12	M16
Perforated sleeve FIS H K	18x130/200		22x130/200

Shear resistance $V_{Rk} = V_{Rk,b} = V_{Rk,c,II} = V_{Rk,c,I}$ [kN] depending on the mean compressive strength f_b ; Installation and use condition w/w, w/d, d/d; (temperature range 50/80°C and 72/120°C)

Mean compressive strength / Min. compressive strength single brick ¹⁾	Use conditions				
	w/w	w/d			
5 / 4 N/mm ²	d/d			1,5	1,2
	w/w	w/d			
8 / 6 N/mm ²	d/d			2,0	1,5
	w/w	w/d			

¹⁾ The compressive strength of the single brick must not be less than 80% of the mean compressive strength.

Factor for job site tests and displacements see annex C 123.

fischer injection system FIS V Plus for masonry

Performance
 Vertical perforated brick HLz, T7 PF, filled with perlite,
 Characteristic resistance under shear loading

Annex C 43

Appendix 72 / 153

Vertical perforated brick HLz, T9 MW, filled with mineral wool, EN 771-1:2011+A1:2015

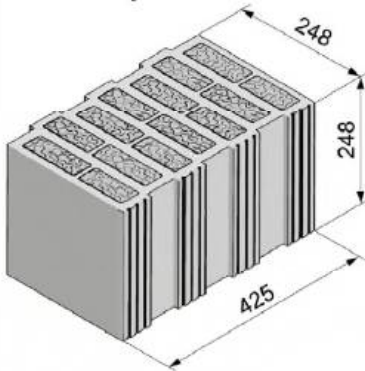

Producer	e.g. Wienerberger			
Nominal dimensions	[mm]	length L	width W	height H
		248	425	248
Mean gross dry density ρ	[kg/dm ³]	0,8		
Mean compressive strength / Min. compressive strength single brick ¹⁾	[N/mm ²]	5 / 4 or 8 / 6 or 10 / 8		
Standard or annex	EN 771-1:2011+A1:2015			

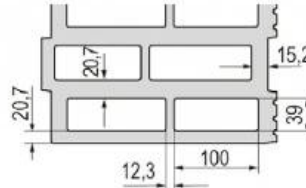

Dimension see also Annex B 16

Table C44.1: Installation parameters
(Pre-positioned anchorage with perforated sleeve FIS H K)

Anchor rod	M6	M8	M6	M8	-	M8	M10	M8	M10	-	M12	M16	M12	M16	M12	M16
Internal threaded anchor FIS E	-	-	M6 M8		-		-		M10 M12		-	-	-	-	-	-
Perforated sleeve FIS H K	12x50		12x85		16x85			16x130		20x85			20x130		20x200	

Anchor rod and internal threaded anchor FIS E with perforated sleeve FIS H K

Max. installation torque $\max T_{inst}$ [Nm]	3					5	3	5				
---	---	--	--	--	--	---	---	---	--	--	--	--

General installation parameters

Edge distance $c_{min} = c_{cr}$						60					
Spacing	$s_{min \parallel}$						80				
	$s_{cr \parallel}$ [mm]						250				
	$s_{min \perp}$						80				
	$s_{cr \perp}$						250				

Drilling method

Rotary drilling with carbide drill

¹⁾ The compressive strength of the single brick must not be less than 80% of the mean compressive strength.

Table C44.2: Group factors

Anchor rod	M6	M8	M6	M8	-	M8	M10	M8	M10	-	M12	M16	M12	M16	M12	M16
Internal threaded anchor FIS E	-	-	M6 M8		-		-		M10 M12		-	-	-	-	-	-
Perforated sleeve FIS H K	12x50		12x85		16x85			16x130		20x85			20x130		20x200	

Group factors	$\alpha_{g,N} (s_{min \parallel})$	[-]						1,3				
	$\alpha_{g,V} (s_{min \parallel})$							1,2				
	$\alpha_{g,N} (s_{min \perp})$							0,6				
	$\alpha_{g,V} (s_{min \perp})$							1,2				

fischer injection system FIS V Plus for masonry

Performance

Vertical perforated brick HLz, T9 MW, filled with mineral wool, dimensions, installation parameters

Annex C 44

Appendix 73 / 153

Vertical perforated brick HLz, T9 MW, filled with mineral wool, EN 771-1:2011+A1:2015

Table C45.1: Installation parameters
(Push through anchorage with perforated sleeve FIS H K)

Anchor rod		M10	M12	M16
Perforated sleeve FIS H K		18x130/200		22x130/200
Anchor rod with perforated sleeve FIS H K				
Max. installation torque	max T _{inst} [Nm]	5		
General installation parameters				
Edge distance	c _{min} = c _{cr}	60		
Spacing	s _{min}	80		
	s _{cr} [mm]	250		
	s _{min} ⊥	80		
	s _{cr} ⊥	250		
Drilling method				
Rotary drilling with carbide drill				

Table C45.2: Group factors

Anchor rod		M10	M12	M16
Perforated sleeve FIS H K		18x130/200		22x130/200
Group factors	α _{g,N} (s _{min})	1,3		
	α _{g,V} (s _{min})	1,2		
	α _{g,N} (s _{min} ⊥)	0,6		
	α _{g,V} (s _{min} ⊥)	1,2		

fischer injection system FIS V Plus for masonry

Performance
Vertical perforated brick HLz, T9 MW, filled with mineral wool,
dimensions, installation parameters

Annex C 45

Appendix 74 / 153

Vertical perforated brick HLz, T9 MW, filled with mineral wool, EN 771-1:2011+A1:2015
Table C46.1: Characteristic resistance to pull-out failure or brick breakout failure of a single anchor under tension loading (Pre-positioned anchorage)

Anchor rod	M6	M8	M6	M8	-	M8	M10	M8	M10	-	M12	M16	M12	M16	M12	M16
Internal threaded anchor FIS E	-		-	M6	M8			-	M10	M12	-			-		
Perforated sleeve FIS H K	12x50	12x85	16x85			16x130		20x85			20x130		20x200			
Tension resistance $N_{Rk} = N_{Rk,p} = N_{Rk,b} = N_{Rk,p,c} = N_{Rk,b,c}$ [kN] depending on the mean compressive strength f_b ; Installation and use condition w/w, w/d, d/d; (temperature range 50/80°C) ²⁾																
Mean compressive strength / Min. compressive strength single brick ¹⁾	Use conditions															
5 / 4 N/mm ²	w/w	w/d	1,5		2,0		3,0		2,5		4,0					
	d/d		2,0		2,5		3,0		2,5		4,5					
8 / 6 N/mm ²	w/w	w/d	2,0		2,5		3,5		3,0		5,0					
	d/d		2,0		3,0		4,0		3,0		5,5					
10 / 8 N/mm ²	w/w	w/d	2,5		3,0		4,0		3,5		6,0					
	d/d		2,5		3,0		4,5		3,5		6,5					

¹⁾ The compressive strength of the single brick must not be less than 80% of the mean compressive strength.

²⁾ For temperature range 72/120°C: $N_{Rk(72/120^\circ C)} = 0,83 \cdot N_{Rk(50/80^\circ C)}$.

Table C46.2: Characteristic resistance to pull-out failure or brick breakout failure of a single anchor under tension loading (Push through anchorage)

Anchor rod	M10		M12		M16	
Perforated sleeve FIS H K	18x130/200				22x130/200	
Tension resistance $N_{Rk} = N_{Rk,p} = N_{Rk,b} = N_{Rk,p,c} = N_{Rk,b,c}$ [kN] depending on the mean compressive strength f_b ; Installation and use condition w/w, w/d, d/d; (temperature range 50/80°C) ²⁾						
Mean compressive strength / Min. compressive strength single brick ¹⁾	Use conditions					
5 / 4 N/mm ²	w/w	w/d	3,0		4,0	
	d/d		3,0		4,5	
8 / 6 N/mm ²	w/w	w/d	3,5		5,0	
	d/d		4,0		5,5	
10 / 8 N/mm ²	w/w	w/d	4,0		6,0	
	d/d		4,5		6,5	

¹⁾ The compressive strength of the single brick must not be less than 80% of the mean compressive strength.

²⁾ For temperature range 72/120°C: $N_{Rk(72/120^\circ C)} = 0,83 \cdot N_{Rk(50/80^\circ C)}$.

Factor for job site tests and displacements see annex C 123.

fischer injection system FIS V Plus for masonry

Performance

 Vertical perforated brick HLz, T9 MW, filled with mineral wool;
 Characteristic resistance under tension loading

Annex C 46

Appendix 75 / 153

Vertical perforated brick HLz, T9 MW, filled with mineral wool, EN 771-1:2011+A1:2015
Table C47.1: Characteristic resistance to local brick failure or brick edge failure of a single anchor under shear loading (Pre-positioned anchorage)

Anchor rod	M6	M8	M6	M8	-	M8	M10	M8	M10	-	M12	M16	M12	M16	M12	M16
Internal threaded anchor FIS E	-		-		M6	M8	-		-		M10	M12	-		-	
Perforated sleeve FIS H K	12x50		12x85		16x85			16x130		20x85			20x130		20x200	

Shear resistance $V_{Rk} = V_{Rk,b} = V_{Rk,c,II} = V_{Rk,c,I}$ [kN] depending on the mean compressive strength f_b ; Installation and use condition w/w, w/d, d/d; (temperature range 50/80°C and 72/120°C)

Mean compressive strength / Min. compressive strength single brick ¹⁾	Use conditions											
	w/w	w/d	d/d									
5 / 4 N/mm²			2,0		2,0		2,5		2,0			1,5
8 / 6 N/mm²			2,5		2,5		3,0		2,5			2,0
10 / 8 N/mm²			2,5		3,0		4,0		3,0			2,5

¹⁾ The compressive strength of the single brick must not be less than 80% of the mean compressive strength.

Table C47.2: Characteristic resistance to local brick failure or brick edge failure of a single anchor under shear loading (Push through anchorage)

Anchor rod	M10	M12	M16
Perforated sleeve FIS H K	18x130/200		22x130/200

Shear resistance $V_{Rk} = V_{Rk,b} = V_{Rk,c,II} = V_{Rk,c,I}$ [kN] depending on the mean compressive strength f_b ; Installation and use condition w/w, w/d, d/d; (temperature range 50/80°C and 72/120°C)

Mean compressive strength / Min. compressive strength single brick ¹⁾	Use conditions					
	w/w	w/d	d/d			
5 / 4 N/mm²				2,5		2,0
8 / 6 N/mm²				3,0		2,5
10 / 8 N/mm²				4,0		3,0

¹⁾ The compressive strength of the single brick must not be less than 80% of the mean compressive strength.

Factor for job site tests and displacements see annex C 123.

fischer injection system FIS V Plus for masonry

Performance

 Vertical perforated brick HLz, T9 MW, filled with mineral wool;
 Characteristic resistance under shear loading

Annex C 47

Appendix 76 / 153

Vertical perforated brick HLz, FZ 7, filled with mineral wool, EN 771-1:2011+A1:2015

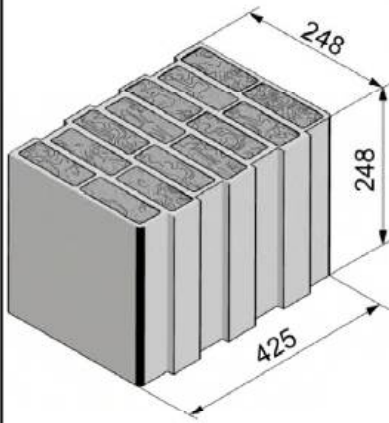

Producer	e.g. Wienerberger		
Nominal dimensions [mm]	length L	width W	height H
	248	425	248
Mean gross dry density ρ [kg/dm ³]	0,8		
Mean compressive strength / Min. compressive strength single brick ¹⁾ [N/mm ²]	5 / 4 or 7,5 / 6 or 10 / 8		
Standard or annex	EN 771-1:2011+A1:2015		

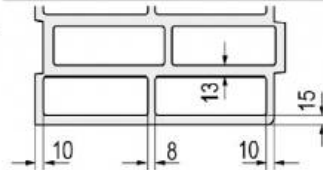

Dimension see also Annex B 16

Table C48.1: Installation parameters
(Pre-positioned anchorage with perforated sleeve FIS H K)

Anchor rod	M6	M8	M6	M8	-	M8	M10	M8	M10	-	M12	M16	M12	M16	M12	M16
Internal threaded anchor FIS E	-	-	-	-	M6	M8	-	-	M10	M12	-	-	-	-	-	-
					11x85				15x85							
Perforated sleeve FIS H K	12x50	12x85	12x85	16x85	16x130	20x85	20x130	20x200								

Anchor rod and internal threaded anchor FIS E with perforated sleeve FIS H K

Max. installation torque $\max T_{inst}$ [Nm]	2	5	2	5
---	---	---	---	---

General installation parameters

Edge distance $c_{min} = c_{cr}$	60	
Spacing	$s_{min II}$	80
	$s_{cr II}$ [mm]	250
	$s_{min \perp}$	80
	$s_{cr \perp}$	250

Drilling method

Rotary drilling with carbide drill

¹⁾ The compressive strength of the single brick must not be less than 80% of the mean compressive strength.

Table C48.2: Group factors

Anchor rod	M6	M8	M6	M8	-	M8	M10	M8	M10	-	M12	M16	M12	M16	M12	M16
Internal threaded anchor FIS E	-	-	-	-	M6	M8	-	-	M10	M12	-	-	-	-	-	-
					11x85				15x85							
Perforated sleeve FIS H K	12x50	12x85	12x85	16x85	16x130	20x85	20x130	20x200								
Group factors	$\alpha_{g,N} (s_{min II})$	1,9					0,9					1,0				
	$\alpha_{g,V} (s_{min II})$	1,9					0,9					1,0				
	$\alpha_{g,N} (s_{min \perp})$	1,9					0,9					1,0				
	$\alpha_{g,V} (s_{min \perp})$	1,9					0,9					1,0				

fischer injection system FIS V Plus for masonry

Performance
Vertical perforated brick HLz, FZ 7, filled with mineral wool;
dimensions, installation parameters

Annex C 48

Appendix 77 / 153

Vertical perforated brick HLz, FZ 7, filled with mineral wool, EN 771-1:2011+A1:2015

Table C49.1: Installation parameters
(Push through anchorage with perforated sleeve FIS H K)

Anchor rod		M10	M12	M16
Perforated sleeve FIS H K		18x130/200		22x130/200
Anchor rod with perforated sleeve FIS H K				
Max. installation torque	T_{inst}	[Nm]	5	
General installation parameters				
Edge distance	$c_{min} = c_{cr}$		60	
	$s_{min \parallel}$		80	
Spacing	$s_{cr \parallel}$	[mm]	250	
	$s_{min \perp}$		80	
	$s_{cr \perp}$		250	
Drilling method				
Rotary drilling with carbide drill				

Table C49.2: Group factors

Anchor rod		M10	M12	M16
Perforated sleeve FIS H K		18x130/200		22x130/200
Group factors	$\alpha_{g,N}(s_{min \parallel})$	[-]	1,9	
	$\alpha_{g,V}(s_{min \parallel})$		0,9	
	$\alpha_{g,N}(s_{min \perp})$		1,0	
	$\alpha_{g,V}(s_{min \perp})$		0,7	

fischer injection system FIS V Plus for masonry

Performance
Vertical perforated brick HLz, FZ 7, filled with mineral wool;
dimensions, installation parameters

Annex C 49

Appendix 78 / 153

Vertical perforated brick HLz, FZ 7, filled with mineral wool, EN 771-1:2011+A1:2015
Table C50.1: Characteristic resistance to pull-out failure or brick breakout failure of a single anchor under tension loading (Pre-positioned anchorage)

Anchor rod	M6	M8	M6	M8	-	M8	M10	M8	M10	-	M12	M16	M12	M16	M12	M16
Internal threaded anchor FIS E	-		-		M6	M8	-		-		M10	M12	-		-	
Perforated sleeve FIS H K	12x50		12x85		16x85		16x130		20x85		20x130		20x200			
Tension resistance $N_{Rk} = N_{Rk,p} = N_{Rk,b} = N_{Rk,p,c} = N_{Rk,b,c}$ [kN] depending on the mean compressive strength f_b ; Installation and use condition w/w, w/d, d/d; (temperature range 50/80°C) ²⁾																
Mean compressive strength / Min. compressive strength single brick ¹⁾		Use conditions														
5 / 4 N/mm ²		w/w	w/d	0,60	0,75	1,50		2,00		1,20		2,00		2,00		
		d/d		0,60	0,90	1,50		2,00		1,50		2,00		2,50		
7,5 / 6 N/mm ²		w/w	w/d	0,75	0,90	1,50		2,00		1,50		2,50		2,50		
		d/d		0,90	0,90	2,00		2,50		2,00		2,50		3,00		
10 / 8 N/mm ²		w/w	w/d	0,90	1,20	2,00		2,50		2,00		2,50		3,00		
		d/d		0,90	1,20	2,00		3,00		2,00		3,00		3,50		

¹⁾ The compressive strength of the single brick must not be less than 80% of the mean compressive strength.

²⁾ For temperature range 72/120°C: $N_{Rk(72/120^\circ C)} = 0,83 \cdot N_{Rk(50/80^\circ C)}$.

Table C50.2: Characteristic resistance to pull-out failure or brick breakout failure of a single anchor under tension loading (Push through anchorage)

Anchor rod	M10		M12		M16	
Perforated sleeve FIS H K	18x130/200				22x130/200	
Tension resistance $N_{Rk} = N_{Rk,p} = N_{Rk,b} = N_{Rk,p,c} = N_{Rk,b,c}$ [kN] depending on the mean compressive strength f_b ; Installation and use condition w/w, w/d, d/d; (temperature range 50/80°C) ²⁾						
Mean compressive strength / Min. compressive strength single brick ¹⁾		Use conditions				
5 / 4 N/mm ²		w/w	w/d	2,0		2,0
		d/d		2,0		2,0
7,5 / 6 N/mm ²		w/w	w/d	2,0		2,5
		d/d		2,5		2,5
10 / 8 N/mm ²		w/w	w/d	2,5		2,5
		d/d		3,0		3,0

¹⁾ The compressive strength of the single brick must not be less than 80% of the mean compressive strength.

²⁾ For temperature range 72/120°C: $N_{Rk(72/120^\circ C)} = 0,83 \cdot N_{Rk(50/80^\circ C)}$.

Factor for job site tests and displacements see annex C 123.

fischer injection system FIS V Plus for masonry

Performance

 Vertical perforated brick HLz, FZ 7, filled with mineral wool;
 Characteristic resistance under tension loading

Annex C 50

Appendix 79 / 153

Vertical perforated brick HLz, FZ 7, filled with mineral wool, EN 771-1:2011+A1:2015
Table C51.1: Characteristic resistance to local brick failure or brick edge failure of a single anchor under shear loading (Pre-positioned anchorage)

Anchor rod	M6	M8	M6	M8	-	M8	M10	M8	M10	-	M12	M16	M12	M16	M12	M16
Internal threaded anchor FIS E	-		-		M6	M8	-		-		M10	M12	-		-	
Perforated sleeve FIS H K	12x50		12x85		16x85			16x130		20x85			20x130		20x200	

Shear resistance $V_{Rk} = V_{Rk,b} = V_{Rk,c,II} = V_{Rk,c,I}$ [kN] depending on the mean compressive strength f_b ; Installation and use condition w/w, w/d, d/d; (temperature range 50/80°C and 72/120°C)

Mean compressive strength / Min. compressive strength single brick ¹⁾	Use conditions															
	w/w	w/d														
5 / 4 N/mm ²	d/d	1,2												1,5	1,5	
7,5 / 6 N/mm ²	d/d	1,5												2,0	1,5	
10 / 8 N/mm ²	d/d	1,5												2,5	2,0	

¹⁾ The compressive strength of the single brick must not be less than 80% of the mean compressive strength.

Table C51.2: Characteristic resistance to local brick failure or brick edge failure of a single anchor under shear loading (Push through anchorage)

Anchor rod	M10		M12		M16			
Perforated sleeve FIS H K	18x130/200				22x130/200			

Shear resistance $V_{Rk} = V_{Rk,b} = V_{Rk,c,II} = V_{Rk,c,I}$ [kN] depending on the mean compressive strength f_b ; Installation and use condition w/w, w/d, d/d; (temperature range 50/80°C and 72/120°C)

Mean compressive strength / Min. compressive strength single brick ¹⁾	Use conditions															
	w/w	w/d														
5 / 4 N/mm ²	d/d	1,5														
7,5 / 6 N/mm ²	d/d	2,0														
10 / 8 N/mm ²	d/d	2,5														

¹⁾ The compressive strength of the single brick must not be less than 80% of the mean compressive strength.

Factor for job site tests and displacements see annex C123.

fischer injection system FIS V Plus for masonry

Performance
 Vertical perforated brick HLz, FZ 7, filled with mineral wool;
 Characteristic resistance under shear loading

Annex C 51

Appendix 80 / 153

Vertical perforated brick HLz, EN 771-1:2011+A1:2015

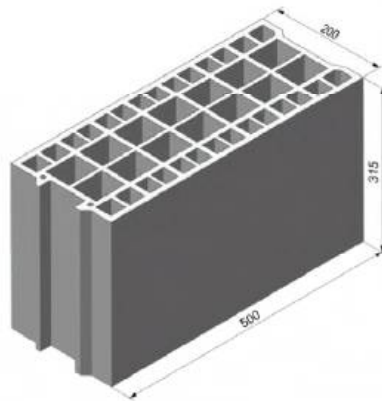

Producer	e.g. Bouyer Leroux			
Nominal dimensions	[mm]	length L	width W	height H
		500	200	315
Mean gross dry density ρ	[kg/dm ³]	≥ 0,6		
Mean compressive strength / Min. compressive strength single brick ¹⁾	[N/mm ²]	5 / 4 or 7,5 / 6 or 10 / 8		
Standard or annex	EN 771-1:2011+A1:2015			

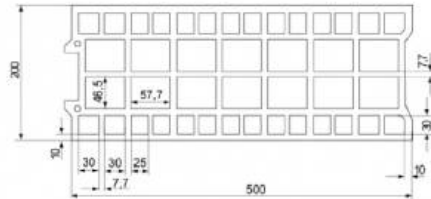

Dimension see also Annex B 16

Table C52.1: Installation parameters
(Pre-positioned anchorage with perforated sleeve FIS H K)

Anchor rod	M6	M8	M6	M8	-	M8	M10	M8	M10	-	M12	M16	M12	M16
Internal threaded anchor FIS E	-		-		M6	M8	-		-		M10	M12	-	
					11x85						15x85			
Perforated sleeve FIS H K	12x50		12x85		16x85			16x130		20x85			20x130	

Anchor rod and internal threaded anchor FIS E with perforated sleeve FIS H K

Max. installation torque $\max T_{inst}$ [Nm]	2													
---	---	--	--	--	--	--	--	--	--	--	--	--	--	--

General installation parameters

Edge distance $c_{min} = c_{cr}$	[mm]	120													
Spacing $s_{min \parallel}$		120													
$s_{cr \parallel}$		500													
$s_{min \perp} = s_{cr \perp}$		315													

Drilling method

Hammer drilling with hard metal hammer drill

¹⁾ The compressive strength of the single brick must not be less than 80% of the mean compressive strength.

Table C52.2: Group factors

Anchor rod	M6	M8	M6	M8	-	M8	M10	M8	M10	-	M12	M16	M12	M16
Internal threaded anchor FIS E	-		-		M6	M8	-		-		M10	M12	-	
					11x85						15x85			
Perforated sleeve FIS H K	12x50		12x85		16x85			16x130		20x85			20x130	
Group factors	[-]	$\alpha_{g,N} (s_{min \parallel})$	1,3											
		$\alpha_{g,V} (s_{min \parallel})$	1,7											
		$\alpha_{g,N} (s_{min \perp})$	2,0											
		$\alpha_{g,V} (s_{min \perp})$												

fischer injection system FIS V Plus for masonry

Performance
Vertical perforated brick HLz, dimensions, installation parameters

Annex C 52

Appendix 81 / 153

Vertical perforated brick HLz, EN 771-1:2011+A1:2015

Table C53.1: Installation parameters
(Push through anchorage with perforated sleeve FIS H K)

Anchor rod	M10	M12	M16
Perforated sleeve FIS H K	18x130/200		22x130/200
Anchor rod with perforated sleeve FIS H K			
Max. installation torque $\max T_{inst}$ [Nm]	2		
General installation parameters			
Edge distance $c_{min} = c_{cr}$	120		
Spacing	$s_{min II}$	120	
	$s_{cr II}$	500	
	$s_{min \perp} = s_{cr \perp}$	315	
Drilling method			
Hammer drilling with hard metal hammer drill			

Table C53.2: Group factors

Anchor rod	M10	M12	M16
Perforated sleeve FIS H K	18x130/200		22x130/200
Group factors	$\alpha_{g,N}(s_{min II})$	1,3	
	$\alpha_{g,V}(s_{min II})$	1,7	
	$\alpha_{g,N}(s_{min \perp})$	2,0	
	$\alpha_{g,V}(s_{min \perp})$	2,0	

fischer injection system FIS V Plus for masonry

Performance
Vertical perforated brick HLz, dimensions, installation parameters

Annex C 53

Appendix 82 / 153

Vertical perforated brick HLz, EN 771-1:2011+A1:2015

Table C54.1: Characteristic resistance to pull-out failure or brick breakout failure of a single anchor under tension loading (Pre-positioned anchorage)

Anchor rod	M6	M8	M6	M8	-	M8	M10	M8	M10	-	M12	M16	M12	M16
Internal threaded anchor FIS E	-		-		M6	M8	-		-		M10	M12	-	
					11x85						15x85			
Perforated sleeve FIS H K	12x50		12x85		16x85			16x130		20x85			20x130	

Tension resistance $N_{Rk} = N_{Rk,p} = N_{Rk,b} = N_{Rk,p,c} = N_{Rk,b,c}$ [kN] depending on the mean compressive strength f_b ; Installation and use condition w/w, w/d, d/d; (temperature range 50/80°C)²⁾

Mean compressive strength / Min. compressive strength single brick ¹⁾	Use conditions										
5 / 4 N/mm ²	w/w	w/d	0,50		1,50		0,75		1,50		1,50
	d/d		0,60		1,50		0,90		1,50		2,00
7,5 / 6 N/mm ²	w/w	w/d	0,75		2,00		1,20		2,00		2,50
	d/d		0,90		2,50		1,20		2,50		2,50
10 / 8 N/mm ²	w/w	w/d	0,90		3,00		1,50		3,00		3,50
	d/d		1,20		3,00		2,00		3,00		3,50

¹⁾ The compressive strength of the single brick must not be less than 80% of the mean compressive strength.

²⁾ For temperature range 72/120°C: $N_{Rk(72/120^\circ C)} = 0,83 \cdot N_{Rk(50/80^\circ C)}$.

Table C54.2: Characteristic resistance to pull-out failure or brick breakout failure of a single anchor under tension loading (Push through anchorage)

Anchor rod	M10		M12		M16	
Perforated sleeve FIS H K	18x130/200				22x130/200	

Tension resistance $N_{Rk} = N_{Rk,p} = N_{Rk,b} = N_{Rk,p,c} = N_{Rk,b,c}$ [kN] depending on the mean compressive strength f_b ; Installation and use condition w/w, w/d, d/d; (temperature range 50/80°C)²⁾

Mean compressive strength / Min. compressive strength single brick ¹⁾	Use conditions					
5 / 4 N/mm ²	w/w	w/d	0,75		1,50	
	d/d		0,90		2,00	
7,5 / 6 N/mm ²	w/w	w/d	1,20		2,50	
	d/d		1,20		2,50	
10 / 8 N/mm ²	w/w	w/d	1,50		3,50	
	d/d		2,00		3,50	

¹⁾ The compressive strength of the single brick must not be less than 80% of the mean compressive strength.

²⁾ For temperature range 72/120°C: $N_{Rk(72/120^\circ C)} = 0,83 \cdot N_{Rk(50/80^\circ C)}$.

Factor for job site tests and displacements see annex C 123.

fischer injection system FIS V Plus for masonry

Performance

Vertical perforated brick HLz, Characteristic resistance under tension loading

Annex C 54

Appendix 83 / 153

Vertical perforated brick HLz, EN 771-1:2011+A1:2015

Table C55.1: Characteristic resistance to local brick failure or brick edge failure of a single anchor under shear loading (Pre-positioned anchorage)

Anchor rod	M6	M8	M6	M8	-	M8	M10	M8	M10	-	M12	M16	M12	M16
Internal threaded anchor FIS E	-		-		M6	M8	-		-		M10	M12	-	
					11x85						15x85			
Perforated sleeve FIS H K	12x50		12x85		16x85			16x130		20x85			20x130	

Shear resistance $V_{Rk} = V_{Rk,b} = V_{Rk,c,II} = V_{Rk,c,\perp}$ [kN] depending on the mean compressive strength f_b ; Installation and use condition w/w, w/d, d/d; (temperature range 50/80°C and 72/120°C)

Mean compressive strength / Min. compressive strength single brick ¹⁾	Use conditions					
5 / 4 N/mm ²	w/w w/d	1,5	0,9	1,5	2,5	0,9
	d/d					
7,5 / 6 N/mm ²	w/w w/d	2,5	1,5	2,5	3,5	1,5
	d/d					
10 / 8 N/mm ²	w/w w/d	3,5	2,0	3,5	4,5	2,0
	d/d					

¹⁾ The compressive strength of the single brick must not be less than 80% of the mean compressive strength.

Table C55.2: Characteristic resistance to local brick failure or brick edge failure of a single anchor under shear loading (Push through anchorage)

Anchor rod	M10	M12	M16
Perforated sleeve FIS H K	18x130/200		22x130/200

Shear resistance $V_{Rk} = V_{Rk,b} = V_{Rk,c,II} = V_{Rk,c,\perp}$ [kN] depending on the mean compressive strength f_b ; Installation and use condition w/w, w/d, d/d; (temperature range 50/80°C and 72/120°C)

Mean compressive strength / Min. compressive strength single brick ¹⁾	Use conditions		
5 / 4 N/mm ²	w/w w/d	0,9	
	d/d		
7,5 / 6 N/mm ²	w/w w/d	1,5	
	d/d		
10 / 8 N/mm ²	w/w w/d	2,0	
	d/d		

¹⁾ The compressive strength of the single brick must not be less than 80% of the mean compressive strength.

Factor for job site tests and displacements see annex C 123.

fischer injection system FIS V Plus for masonry

Performance
Vertical perforated brick HLz, Characteristic resistance under shear loading

Annex C 55

Appendix 84 / 153

Vertical perforated brick HLz, EN 771-1:2011+A1:2015

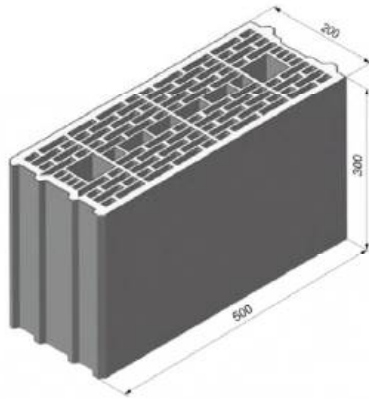

Producer	e.g. Wienerberger			
Nominal dimensions	[mm]	length L	width W	height H
		500	200	300
Mean gross dry density ρ	[kg/dm ³]	≥ 0,7		
Mean compressive strength / Min. compressive strength single brick ¹⁾	[N/mm ²]	5 / 4 or 7,5 / 6 or 10 / 8 12,5 / 10		
Standard or annex	EN 771-1:2011+A1:2015			

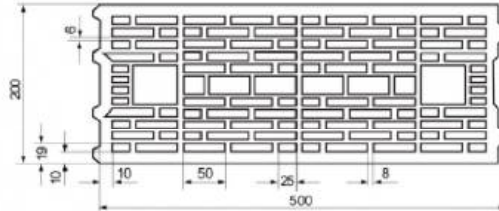

Dimension see also Annex B 17

Table C56.1: Installation parameters
(Pre-positioned anchorage with perforated sleeve FIS H K)

Anchor rod	M6	M8	M6	M8	-	M8	M10	M8	M10	-	M12	M16	M12	M16
Internal threaded anchor FIS E	-		-		M6	M8	-		-		M10	M12	-	
					11x85						15x85			
Perforated sleeve FIS H K	12x50		12x85		16x85			16x130		20x85			20x130	

Anchor rod and internal threaded anchor FIS E with perforated sleeve FIS H K

Max. installation torque $\max T_{inst}$ [Nm]	2													
---	---	--	--	--	--	--	--	--	--	--	--	--	--	--

General installation parameters

Edge distance $c_{min} = c_{cr}$	50				80				50		80		
Spacing	$s_{min \parallel}$	100											
	$s_{cr \parallel}$	500											
	$s_{min \perp} = s_{cr \perp}$	300											

Drilling method

Hammer drilling with hard metal hammer drill

¹⁾ The compressive strength of the single brick must not be less than 80% of the mean compressive strength.

Table C56.2: Group factors

Anchor rod	M6	M8	M6	M8	-	M8	M10	M8	M10	-	M12	M16	M12	M16
Internal threaded anchor FIS E	-		-		M6	M8	-		-		M10	M12	-	
					11x85						15x85			
Perforated sleeve FIS H K	12x50		12x85		16x85			16x130		20x85			20x130	
Group factors	$\alpha_{g,N} (s_{min \parallel})$	1,4												
	$\alpha_{g,V} (s_{min \parallel})$	2												
	$\alpha_{g,N} (s_{min \perp})$	2												
	$\alpha_{g,V} (s_{min \perp})$	2												

fischer injection system FIS V Plus for masonry

Performance
Vertical perforated brick HLz, dimensions, installation parameters

Annex C 56

Appendix 85 / 153

Vertical perforated brick HLz, EN 771-1:2011+A1:2015

Table C57.1: Installation parameters
(Push through anchorage with perforated sleeve FIS H K)

Anchor rod	M10	M12	M16
Perforated sleeve FIS H K	18x130/200		22x130/200
Anchor rod with perforated sleeve FIS H K			
Max. installation torque $\max T_{inst}$ [Nm]	2		
General installation parameters			
Edge distance $c_{min} = c_{cr}$	80		
Spacing	$s_{min \parallel}$	100	
	$s_{cr \parallel}$	500	
	$s_{min \perp} = s_{cr \perp}$	300	
Drilling method			
Hammer drilling with hard metal hammer drill			

Table C57.2: Group factors

Anchor rod	M10	M12	M16
Perforated sleeve FIS H K	18x130/200		22x130/200
Group factors	$\alpha_{g,N}(s_{min \parallel})$	1,4	
	$\alpha_{g,V}(s_{min \parallel})$	2	
	$\alpha_{g,N}(s_{min \perp})$		
	$\alpha_{g,V}(s_{min \perp})$		

fischer injection system FIS V Plus for masonry

Performance
Vertical perforated brick HLz, dimensions, installation parameters

Annex C 57

Appendix 86 / 153

Vertical perforated brick HLz, EN 771-1:2011+A1:2015

Table C58.1: Characteristic resistance to pull-out failure or brick breakout failure of a single anchor under tension loading (Pre-positioned anchorage)

Anchor rod	M6	M8	M6	M8	-	M8	M10	M8	M10	-	M12	M16	M12	M16
Internal threaded anchor FIS E	-		-		M6 M8	-		-		M10 M12	-		-	
Perforated sleeve FIS H K	12x50		12x85		16x85			16x130		20x85			20x130	
Tension resistance $N_{Rk} = N_{Rk,p} = N_{Rk,b} = N_{Rk,p,c} = N_{Rk,b,c}$ [kN] depending on the mean compressive strength f_b ; Installation and use condition w/w, w/d, d/d; (temperature range 50/80°C) ²⁾														
Mean compressive strength / Min. compressive strength single brick ¹⁾	Use conditions													
5 / 4 N/mm ²	w/w	w/d	0,50		0,60			1,20		0,75			1,50	
	d/d		0,60		0,75			1,20		0,90			1,50	
7,5 / 6 N/mm ²	w/w	w/d	0,75		0,90			1,50		1,20			2,00	
	d/d		0,90		1,20			2,00		1,20			2,50	
10 / 8 N/mm ²	w/w	w/d	0,90		1,20			2,00		1,50			2,50	
	d/d		1,20		1,50			2,50		1,50			3,00	
12,5 / 10 N/mm ²	w/w	w/d	1,20		1,50			2,50		2,00			3,50	
	d/d		1,50		2,00			3,00		2,00			4,00	

¹⁾ The compressive strength of the single brick must not be less than 80% of the mean compressive strength.

²⁾ For temperature range 72/120°C: $N_{Rk(72/120^\circ C)} = 0,83 \cdot N_{Rk(50/80^\circ C)}$.

Table C58.2: Characteristic resistance to pull-out failure or brick breakout failure of a single anchor under tension loading (Push through anchorage)

Anchor rod	M10		M12		M16	
Perforated sleeve FIS H K	18x130/200				22x130/200	
Tension resistance $N_{Rk} = N_{Rk,p} = N_{Rk,b} = N_{Rk,p,c} = N_{Rk,b,c}$ [kN] depending on the mean compressive strength f_b ; Installation and use condition w/w, w/d, d/d; (temperature range 50/80°C) ²⁾						
Mean compressive strength / Min. compressive strength single brick ¹⁾	Use conditions					
5 / 4 N/mm ²	w/w	w/d	1,2		1,5	
	d/d		1,2		1,5	
7,5 / 6 N/mm ²	w/w	w/d	1,5		2,0	
	d/d		2,0		2,5	
10 / 8 N/mm ²	w/w	w/d	2,0		2,5	
	d/d		2,5		3,0	
12,5 / 10 N/mm ²	w/w	w/d	2,5		3,5	
	d/d		3,0		4,0	

¹⁾ The compressive strength of the single brick must not be less than 80% of the mean compressive strength.

²⁾ For temperature range 72/120°C: $N_{Rk(72/120^\circ C)} = 0,83 \cdot N_{Rk(50/80^\circ C)}$.

Factor for job site tests and displacements see annex C 123.

fischer injection system FIS V Plus for masonry

Performance
Vertical perforated brick HLz, Characteristic resistance under tension loading

Annex C 58

Appendix 87 / 153

Vertical perforated brick HLz, EN 771-1:2011+A1:2015

Table C59.1: Characteristic resistance to local brick failure or brick edge failure of a single anchor under shear loading (Pre-positioned anchorage)

Anchor rod	M6	M8	M6	M8	-	M8	M10	M8	M10	-	M12	M16	M12	M16
Internal threaded anchor FIS E	-		-		M6	M8	-		-		M10	M12	-	
					11x85						15x85			
Perforated sleeve FIS H K	12x50		12x85		16x85			16x130		20x85			20x130	
Shear resistance $V_{Rk} = V_{Rk,b} = V_{Rk,c,II} = V_{Rk,c,\perp}$ [kN] depending on the mean compressive strength f_b ; Installation and use condition w/w, w/d, d/d; (temperature range 50/80°C and 72/120°C)														
Mean compressive strength / Min. compressive strength single brick ¹⁾	Use conditions													
5 / 4 N/mm ²	w/w	w/d	0,9	1,2	0,9	1,2	0,6	2,0	0,6					
	d/d													
7,5 / 6 N/mm ²	w/w	w/d	1,2	1,5	1,2	1,5	0,9	3,0	0,9					
	d/d													
10 / 8 N/mm ²	w/w	w/d	1,5	2,0	1,5	2,0	1,2	4,0	1,2					
	d/d													
12,5 / 10 N/mm ²	w/w	w/d	2,0	3,0	2,0	3,0	1,5	5,0	1,5					
	d/d													

¹⁾ The compressive strength of the single brick must not be less than 80% of the mean compressive strength.

Table C59.2: Characteristic resistance to local brick failure or brick edge failure of a single anchor under shear loading (Push through anchorage)

Anchor rod	M10		M12		M16	
Perforated sleeve FIS H K	18x130/200				22x130/200	
Shear resistance $V_{Rk} = V_{Rk,b} = V_{Rk,c,II} = V_{Rk,c,\perp}$ [kN] depending on the mean compressive strength f_b ; Installation and use condition w/w, w/d, d/d; (temperature range 50/80°C and 72/120°C)						
Mean compressive strength / Min. compressive strength single brick ¹⁾	Use conditions					
5 / 4 N/mm ²	w/w	w/d	0,6			
	d/d					
7,5 / 6 N/mm ²	w/w	w/d	0,9			
	d/d					
10 / 8 N/mm ²	w/w	w/d	1,2			
	d/d					
12,5 / 10 N/mm ²	w/w	w/d	1,5			
	d/d					

¹⁾ The compressive strength of the single brick must not be less than 80% of the mean compressive strength. Factor for job site tests and displacements see annex C 123.

fischer injection system FIS V Plus for masonry

Performance
Vertical perforated brick HLz, Characteristic resistance under shear loading

Annex C 59

Appendix 88 / 153

Vertical perforated brick HLz, EN 771-1:2011+A1:2015

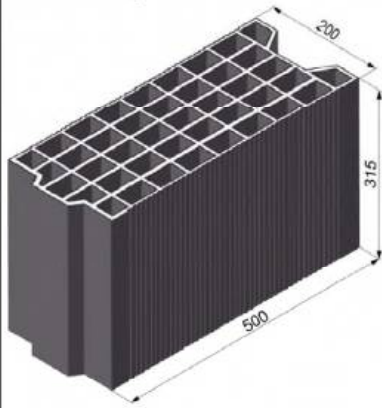

Producer	e.g. Terreal			
Nominal dimensions	[mm]	length L	width W	height H
		500	200	315
Mean gross dry density ρ	[kg/dm ³]	≥ 0,7		
Mean compressive strength / Min. compressive strength single brick ¹⁾	[N/mm ²]	2,5 / 2 or 5 / 4 or 7,5 / 6 or 10 / 8		
Standard or annex	EN 771-1:2011+A1:2015			

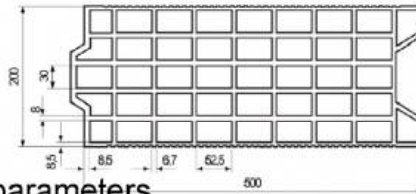

Dimension see also Annex B 17

Table C60.1: Installation parameters
(Pre-positioned anchorage with perforated sleeve FIS H K)

Anchor rod	M6	M8	M6	M8	-	M8	M10	M8	M10	-	M12	M16	M12	M16
Internal threaded anchor FIS E	-		-		M6	M8	-		-		M10	M12	-	
					11x85						15x85			
Perforated sleeve FIS H K	12x50		12x85		16x85			16x130		20x85			20x130	

Anchor rod and internal threaded anchor FIS E with perforated sleeve FIS H K

Max. installation torque $\max T_{inst}$ [Nm]	2													
---	---	--	--	--	--	--	--	--	--	--	--	--	--	--

General installation parameters

Edge distance $c_{min} = c_{cr}$	50				80				50				80			
Spacing	s_{min} II	s_{scr} II [mm]	[mm]	100												
				500												
				100												
				315												

Drilling method

Hammer drilling with hard metal hammer drill

¹⁾ The compressive strength of the single brick must not be less than 80% of the mean compressive strength.

Table C60.2: Group factors

Anchor rod	M6	M8	M6	M8	-	M8	M10	M8	M10	-	M12	M16	M12	M16
Internal threaded anchor FIS E	-		-		M6	M8	-		-		M10	M12	-	
					11x85						15x85			
Perforated sleeve FIS H K	12x50		12x85		16x85			16x130		20x85			20x130	
Group factors	$\alpha_{g,N}$ (s_{min} II)	$\alpha_{g,V}$ (s_{min} II)	$\alpha_{g,N}$ (s_{min} \perp)	$\alpha_{g,V}$ (s_{min} \perp)	[-]	1,1								
						1,2								
						1,1								
						1,2								

fischer injection system FIS V Plus for masonry

Performance
Vertical perforated brick HLz, dimensions, installation parameters

Annex C 60

Appendix 89 / 153

Vertical perforated brick HLz, EN 771-1:2011+A1:2015

Table C61.1: Installation parameters
(Push through anchorage with perforated sleeve FIS H K)

Anchor rod		M10	M12	M16
Perforated sleeve FIS H K		18x130/200		22x130/200
Anchor rod with perforated sleeve FIS H K				
Max. installation torque	$\max T_{inst}$ [Nm]	2		
General installation parameters				
Edge distance	$c_{min} = c_{cr}$	80		
Spacing	$s_{min \parallel}$	100		
	$s_{cr \parallel}$ [mm]	500		
	$s_{min \perp}$	100		
	$s_{cr \perp}$	315		
Drilling method				
Hammer drilling with hard metal hammer drill				

Table C61.2: Group factors

Anchor rod		M10	M12	M16
Perforated sleeve FIS H K		18x130/200		22x130/200
Group factors	$\alpha_{g,N} (s_{min \parallel})$	1,1		
	$\alpha_{g,V} (s_{min \parallel})$	1,2		
	$\alpha_{g,N} (s_{min \perp})$	1,1		
	$\alpha_{g,V} (s_{min \perp})$	1,2		

fischer injection system FIS V Plus for masonry

Performance
Vertical perforated brick HLz, dimensions, installation parameters

Annex C 61

Appendix 90 / 153

Vertical perforated brick HLz, EN 771-1:2011+A1:2015

Table C62.1: Characteristic resistance to pull-out failure or brick breakout failure of a single anchor under tension loading (Pre-positioned anchorage)

Anchor rod	M6	M8	M6	M8	-	M8	M10	M8	M10	-	M12	M16	M12	M16
Internal threaded anchor FIS E	-		-		M6	M8	-		-		M10	M12	-	
Perforated sleeve FIS H K	12x50		12x85		16x85			16x130		20x85			20x130	

Tension resistance $N_{Rk} = N_{Rk,p} = N_{Rk,b} = N_{Rk,p,c} = N_{Rk,b,c}$ [kN] depending on the mean compressive strength f_b ; Installation and use condition w/w, w/d, d/d; (temperature range 50/80°C)²⁾

Mean compressive strength / Min. compressive strength single brick ¹⁾	Use conditions				
2,5 / 2 N/mm ²	w/w w/d	0,5			
	d/d	0,5		0,6	0,5
5 / 4 N/mm ²	w/w w/d	0,9			
	d/d	0,9	1,2		
7,5 / 6 N/mm ²	w/w w/d	1,5			
	d/d	1,5			
10 / 8 N/mm ²	w/w w/d	2,0			
	d/d	2,0			

¹⁾ The compressive strength of the single brick must not be less than 80% of the mean compressive strength.

²⁾ For temperature range 72/120°C: $N_{Rk(72/120^\circ C)} = 0,83 \cdot N_{Rk(50/80^\circ C)}$.

Table C62.2: Characteristic resistance to pull-out failure or brick breakout failure of a single anchor under tension loading (Push through anchorage)

Anchor rod	M10	M12	M16
Perforated sleeve FIS H K	18x130/200		22x130/200

Tension resistance $N_{Rk} = N_{Rk,p} = N_{Rk,b} = N_{Rk,p,c} = N_{Rk,b,c}$ [kN] depending on the mean compressive strength f_b ; Installation and use condition w/w, w/d, d/d; (temperature range 50/80°C)²⁾

Mean compressive strength / Min. compressive strength single brick ¹⁾	Use conditions		
2,5 / 2 N/mm ²	w/w w/d	0,5	
	d/d	0,6	
5 / 4 N/mm ²	w/w w/d	0,9	
	d/d	1,2	
7,5 / 6 N/mm ²	w/w w/d	1,5	
	d/d	1,5	
10 / 8 N/mm ²	w/w w/d	2,0	
	d/d	2,0	

¹⁾ The compressive strength of the single brick must not be less than 80% of the mean compressive strength.

²⁾ For temperature range 72/120°C: $N_{Rk(72/120^\circ C)} = 0,83 \cdot N_{Rk(50/80^\circ C)}$.

Factor for job site tests and displacements see annex C 123.

fischer injection system FIS V Plus for masonry

Performance

Vertical perforated brick HLz, Characteristic resistance under tension loading

Annex C 62

Appendix 91 / 153

Vertical perforated brick HLz, EN 771-1:2011+A1:2015

Table C63.1: Characteristic resistance to local brick failure or brick edge failure of a single anchor under shear loading (Pre-positioned anchorage)

Anchor rod	M6	M8	M6	M8	-	M8	M10	M8	M10	-	M12	M16	M12	M16
Internal threaded anchor FIS E	-		-		M6	M8	-		-		M10	M12	-	
					11x85						15x85			
Perforated sleeve FIS H K	12x50		12x85		16x85			16x130		20x85			20x130	

Shear resistance $V_{Rk} = V_{Rk,b} = V_{Rk,c,II} = V_{Rk,c,I}$ [kN] depending on the mean compressive strength f_b ; Installation and use condition w/w, w/d, d/d; (temperature range 50/80°C and 72/120°C)

Mean compressive strength / Min. compressive strength single brick ¹⁾	Use conditions														
2,5 / 2 N/mm ²	w/w w/d	0,30	0,60	0,3	0,60	0,60	0,90	0,75							
	d/d														
5 / 4 N/mm ²	w/w w/d	0,75	1,20	0,7	1,20	1,20	2,00	1,50							
	d/d														
7,5 / 6 N/mm ²	w/w w/d	0,90	2,00	0,9	2,00	1,50	3,00	2,00							
	d/d														
10 / 8 N/mm ²	w/w w/d	1,50	2,50	1,5	2,50	2,00	4,00	3,00							
	d/d														

¹⁾ The compressive strength of the single brick must not be less than 80% of the mean compressive strength.

Table C63.2: Characteristic resistance to local brick failure or brick edge failure of a single anchor under shear loading (Push through anchorage)

Anchor rod	M10		M12		M16	
Perforated sleeve FIS H K	18x130/200				22x130/200	

Shear resistance $V_{Rk} = V_{Rk,b} = V_{Rk,c,II} = V_{Rk,c,I}$ [kN] depending on the mean compressive strength f_b ; Installation and use condition w/w, w/d, d/d; (temperature range 50/80°C and 72/120°C)

Mean compressive strength / Min. compressive strength single brick ¹⁾	Use conditions						
2,5 / 2 N/mm ²	w/w w/d	0,60	0,75				
	d/d						
5 / 4 N/mm ²	w/w w/d	1,20	1,50				
	d/d						
7,5 / 6 N/mm ²	w/w w/d	1,50	2,00				
	d/d						
10 / 8 N/mm ²	w/w w/d	2,00	3,00				
	d/d						

¹⁾ The compressive strength of the single brick must not be less than 80% of the mean compressive strength. Factor for job site tests and displacements see annex C 123.

fischer injection system FIS V Plus for masonry

Performance

Vertical perforated brick HLz, Characteristic resistance under shear loading

Annex C 63

Appendix 92 / 153

Vertical perforated brick HLz, EN 771-1:2011+A1:2015

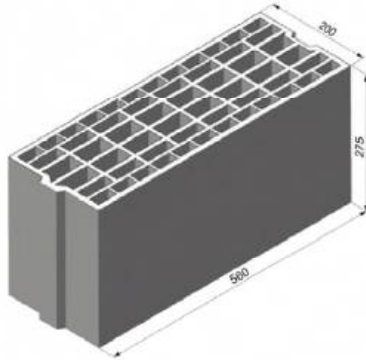

Producer		e.g. Imery		
Nominal dimensions	[mm]	length L	width W	height H
		560	200	275
Mean gross dry density ρ	[kg/dm ³]	≥ 0,7		
Mean compressive strength / Min. compressive strength single brick ¹⁾	[N/mm ²]	5 / 4 or 8 / 6 or 10 / 8		
Standard or annex		EN 771-1:2011+A1:2015		

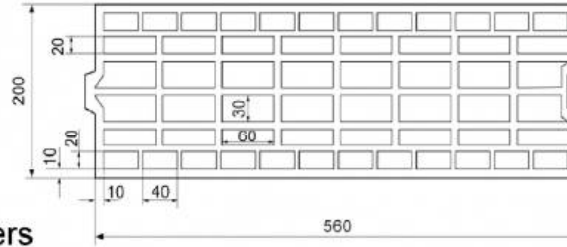

Dimension see also Annex B 17

Table C64.1: Installation parameters

Anchor rod	M8	M10	M10	M12	M12	M16	M16
Perforated sleeve FIS H K	16x130		18x130/200		20x130		22x130/200
Anchor rod with perforated sleeve FIS H K							
Max. installation torque $\max T_{inst}$ [Nm]	2						
General installation parameters							
Edge distance $c_{min} = c_{cr}$	80						
Spacing [mm]	$s_{min \parallel} = s_{cr \parallel}$						
	$s_{min \perp} = s_{cr \perp}$						
Drilling method							
Hammer drilling with hard metal hammer drill							

¹⁾ The compressive strength of the single brick must not be less than 80% of the mean compressive strength.

Table C64.2: Group factors

Anchor rod	M8	M10	M10	M12	M12	M16	M16
Perforated sleeve FIS H K	16x130		18x130/200		20x130		22x130/200
Group factors	$\alpha_{g,N} (s_{min \parallel})$	[-]	2				
	$\alpha_{g,V} (s_{min \parallel})$						
	$\alpha_{g,N} (s_{min \perp})$						
	$\alpha_{g,V} (s_{min \perp})$						

fischer injection system FIS V Plus for masonry

Performance
Vertical perforated brick HLz, dimensions, installation parameters

Annex C 64

Appendix 93 / 153

Vertical perforated brick HLz, EN 771-1:2011+A1:2015

Table C65.1: Characteristic resistance to pull-out failure or brick breakout failure of a single anchor under tension loading

Anchor rod		M8	M10	M10	M12	M12	M16	M16
Perforated sleeve FIS H K		16x130		18x130/200		20x130		22x130/200
Tension resistance $N_{Rk} = N_{Rk,p} = N_{Rk,b} = N_{Rk,p,c} = N_{Rk,b,c}$ [kN] depending on the mean compressive strength f_b ; Installation and use condition w/w, w/d, d/d; (temperature range 50/80°C) ²⁾								
Mean compressive strength / Min. compressive strength single brick ¹⁾	Use conditions							
	w/w	w/d	0,9			1,2		
5 / 4 N/mm ²	d/d		1,2			1,5		
	w/w	w/d	1,5			2,0		
8 / 6 N/mm ²	d/d		1,5			2,0		
	w/w	w/d	2,0			2,5		
10 / 8 N/mm ²	d/d		2,5			3,0		

¹⁾ The compressive strength of the single brick must not be less than 80% of the mean compressive strength.

²⁾ For temperature range 72/120°C: $N_{Rk(72/120^\circ C)} = 0,83 \cdot N_{Rk(50/80^\circ C)}$.

Table C65.2: Characteristic resistance to local brick failure or brick edge failure of a single anchor under shear loading

Anchor rod		M8	M10	M10	M12	M12	M16	M16
Perforated sleeve FIS H K		16x130		18x130/200		20x130		22x130/200
Shear resistance $V_{Rk} = V_{Rk,b} = V_{Rk,c,II} = V_{Rk,c,\perp}$ [kN] depending on the mean compressive strength f_b ; Installation and use condition w/w, w/d, d/d; (temperature range 50/80°C and 72/120°C)								
Mean compressive strength / Min. compressive strength single brick ¹⁾	Use conditions							
	w/w	w/d	0,9					
5 / 4 N/mm ²	d/d							
	w/w	w/d	1,5					
8 / 6 N/mm ²	d/d		1,5					
	w/w	w/d	2,0					
10 / 8 N/mm ²	d/d		2,0					

¹⁾ The compressive strength of the single brick must not be less than 80% of the mean compressive strength. Factor for job site tests and displacements see annex C 123.

fischer injection system FIS V Plus for masonry

Performance

Vertical perforated brick HLz, Characteristic resistance under tension and shear loading

Annex C 65

Appendix 94 / 153

Vertical perforated brick HLz, EN 771-1:2011+A1:2015

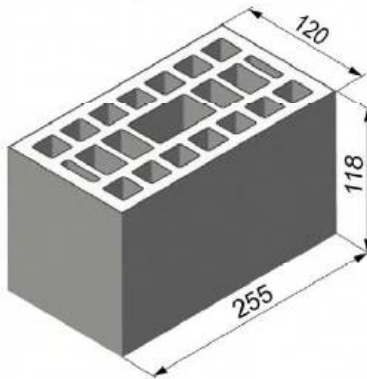

Producer	e.g. Wienerberger			
Nominal dimensions	[mm]	length L	width W	height H
		255	120	118
Mean gross dry density ρ	[kg/dm ³]	$\geq 1,0$		
Mean compressive strength / Min. compressive strength single brick ¹⁾	[N/mm ²]	2,5 / 2 or 5 / 4 or 8 / 6 or 10 / 8 or 12,5 / 10 / or 15 / 12		
Standard or annex	EN 771-1:2011+A1:2015			

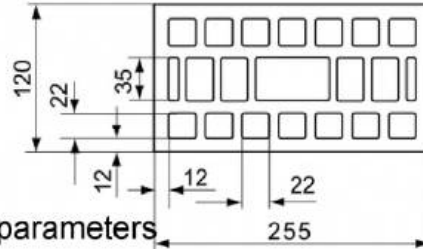

Dimension see also Annex B 18

Table C66.1: Installation parameters

Anchor rod	M6	M8	M6	M8	-	M8	M10	-	M12	M16
Internal threaded anchor FIS E	-	-	-	-	M6	M8	-	M10	M12	-
					11x85			15x85		
Perforated sleeve FIS H K	12x50		12x85		16x85			20x85		

Anchor rod and internal threaded anchor FIS E with perforated sleeve FIS H K

Max. installation torque $\max T_{inst}$ [Nm]	2									
---	---	--	--	--	--	--	--	--	--	--

General installation parameters

Edge distance $c_{min} = c_{cr}$	60									
Spacing $s_{cr \parallel} = s_{min \parallel}$	255									
	$s_{cr \perp} = s_{min \perp}$	120								

Drilling method

Hammer drilling with hard metal hammer drill

¹⁾ The compressive strength of the single brick must not be less than 80% of the mean compressive strength.

Table C66.2: Group factors

Anchor rod	M6	M8	M6	M8	-	M8	M10	-	M12	M16
Internal threaded anchor FIS E	-	-	-	-	M6	M8	-	M10	M12	-
					11x85			15x85		
Perforated sleeve FIS H K	12x50		12x85		16x85			20x85		

Group factors	$\alpha_{g,N} (s_{min \parallel})$	[-]	2							
	$\alpha_{g,V} (s_{min \parallel})$									
	$\alpha_{g,N} (s_{min \perp})$									
	$\alpha_{g,V} (s_{min \perp})$									

fischer injection system FIS V Plus for masonry

Performance
Vertical perforated brick HLz, dimensions, installation parameters

Annex C 66

Appendix 95 / 153

Vertical perforated brick HLz, EN 771-1:2011+A1:2015

Table C67.1: Characteristic resistance to pull-out failure or brick breakout failure of a single anchor under tension loading

Anchor rod	M6	M8	M6	M8	-	M8	M10	-	M12	M16	
Internal threaded anchor FIS E	-		-		M6	M8	-		M10	M12	-
	-		-		11x85		-		15x85		-
Perforated sleeve FIS H K	12x50		12x85		16x85			20x85			
Tension resistance $N_{Rk} = N_{Rk,p} = N_{Rk,b} = N_{Rk,p,c} = N_{Rk,b,c}$ [kN] depending on the mean compressive strength f_b ; Installation and use condition w/w, w/d, d/d; (temperature range 50/80°C) ¹⁾											
Mean compressive strength / Min. compressive strength single brick ²⁾	Use conditions										
2,5 / 2 N/mm ²	w/w	w/d	0,40		0,50			- ³⁾			
	d/d		0,50		0,50			- ³⁾			
5 / 4 N/mm ²	w/w	w/d	0,90		0,90			0,50			
	d/d		0,90		1,20			0,50			
8 / 6 N/mm ²	w/w	w/d	1,20		1,50			0,75			
	d/d		1,50		1,50			0,75			
10 / 8 N/mm ²	w/w	w/d	1,50		2,00			0,90			
	d/d		2,00		2,00			0,90			
12,5 / 10 N/mm ²	w/w	w/d	2,00		2,50			1,20			
	d/d		2,50		2,50			1,20			
15 / 12 N/mm ²	w/w	w/d	2,50		3,00			1,50			
	d/d		3,00		3,50			1,50			

1) For temperature range 72/120°C: $N_{Rk(72/120^\circ C)} = 0,83 \cdot N_{Rk(50/80^\circ C)}$.

2) The compressive strength of the single brick must not be less than 80% of the mean compressive strength.

3) No performance assessed

Factor for job site tests and displacements see annex C 123.

fischer injection system FIS V Plus for masonry

Performance

Vertical perforated brick HLz, Characteristic resistance under tension loading

Annex C 67

Appendix 96 / 153

Vertical perforated brick HLz, EN 771-1:2011+A1:2015

Table C68.1: Characteristic resistance to local brick failure or brick edge failure of a single anchor under shear loading

Anchor rod	M6	M8	M6	M8	-	M8	M10	-	M12	M16	
Internal threaded anchor FIS E	-		-		M6	M8	-		M10	M12	-
					11x85				15x85		
Perforated sleeve FIS H K	12x50		12x85		16x85			20x85			
Shear resistance $V_{Rk} = V_{Rk,b} = V_{Rk,c,II} = V_{Rk,c,\perp}$ [kN] depending on the mean compressive strength f_b ; Installation and use condition w/w, w/d, d/d; (temperature range 50/80°C and 72/120°C)											
Mean compressive strength / Min. compressive strength single brick ¹⁾	Use con- dition										
2,5 / 2 N/mm ²	w/w	w/d	0,60	0,75	0,60	0,75	0,90				
	d/d										
5 / 4 N/mm ²	w/w	w/d	1,20	1,50	1,20	1,50	2,00				
	d/d										
8 / 6 N/mm ²	w/w	w/d	2,00	2,00	2,00	2,00	2,50				
	d/d										
10 / 8 N/mm ²	w/w	w/d	2,50	3,00	2,50	3,00	3,50				
	d/d										
12,5 / 10 N/mm ²	w/w	w/d	3,00	3,50	3,00	3,50	4,50				
	d/d										
15 / 12 N/mm ²	w/w	w/d	4,00	4,50	4,00	4,50	5,50				
	d/d										

¹⁾ The compressive strength of the single brick must not be less than 80% of the mean compressive strength.

Factor for job site tests and displacements see annex C 123.

fischer injection system FIS V Plus for masonry

Performance

Vertical perforated brick HLz, Characteristic resistance under shear loading

Annex C 68

Appendix 97 / 153

Vertical perforated brick HLz, EN 771-1:2011+A1:2015

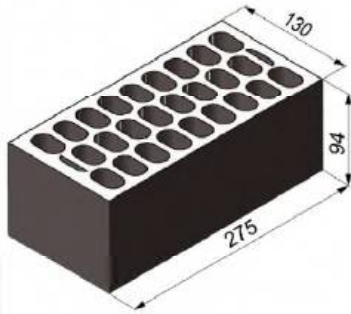

Producer	e.g. Ceramica Farreny S.A.			
Nominal dimensions	[mm]	length L	width W	height H
		275	130	94
Mean gross dry density ρ	[kg/dm ³]	≥ 0,8		
Mean compressive strength / Min. compressive strength single brick ¹⁾	[N/mm ²]	7,5 / 6 or 10 / 8 or 15 / 12 or 20 / 16 or 25 / 20		
Standard or annex	EN 771-1:2011+A1:2015			

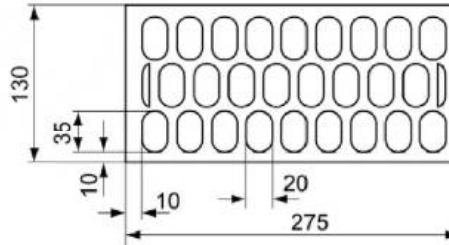

Dimension see also Annex B 18

Table C69.1: Installation parameters

Anchor rod	M6	M8	M6	M8	-	M8	M10	-	M12	M16
Internal threaded anchor FIS E	-		-		M6	M8	-	M10	M12	-
					11x85			15x85		
Perforated sleeve FIS H K	12x50		12x85		16x85			20x85		

Anchor rod and internal threaded anchor FIS E with perforated sleeve FIS H K

Max. installation torque $\max T_{inst}$ [Nm]	2									
---	---	--	--	--	--	--	--	--	--	--

General installation parameters

Edge distance $c_{min} = c_{cr}$	100					120				
Spacing $s_{cr \parallel} = s_{min \parallel}$ [mm]	275									
	$s_{cr \perp} = s_{min \perp}$	95								

Drilling method

Hammer drilling with hard metal hammer drill

¹⁾ The compressive strength of the single brick must not be less than 80% of the mean compressive strength.

Table C69.2: Group factors

Anchor rod	M6	M8	M6	M8	-	M8	M10	-	M12	M16
Internal threaded anchor FIS E	-		-		M6	M8	-	M10	M12	-
					11x85			15x85		
Perforated sleeve FIS H K	12x50		12x85		16x85			20x85		

Group factors	$\alpha_{g,N} (s_{min \parallel})$	[-]	2							
	$\alpha_{g,V} (s_{min \parallel})$									
	$\alpha_{g,N} (s_{min \perp})$									
	$\alpha_{g,V} (s_{min \perp})$									

fischer injection system FIS V Plus for masonry

Performance
Vertical perforated brick HLz, dimensions, installation parameters

Annex C 69

Appendix 98 / 153

Vertical perforated brick HLz, EN 771-1:2011+A1:2015

Table C70.1: Characteristic resistance to pull-out failure or brick breakout failure of a single anchor under tension loading

Anchor rod		M6	M8	M6	M8	-		M8	M10	-		M12	M16	
Internal threaded anchor FIS E		-		-		M6	M8	-		M10	M12	-		
						11x85				15x85				
Perforated sleeve FIS H K		12x50		12x85		16x85				20x85				
Tension resistance $N_{Rk} = N_{Rk,p} = N_{Rk,b} = N_{Rk,p,c} = N_{Rk,b,c}$ [kN] depending on the mean compressive strength f_b ; Installation and use condition w/w, w/d, d/d; (temperature range 50/80°C) ²⁾														
Mean compressive strength / Min. compressive strength single brick ¹⁾		Use conditions												
7,5 / 6 N/mm ²	w/w	w/d	0,40										0,90	
		d/d	0,40										0,90	
10 / 8 N/mm ²	w/w	w/d	0,50										1,20	
		d/d	0,60										1,20	
15 / 12 N/mm ²	w/w	w/d	0,75										1,50	
		d/d	0,90										2,00	
20 / 16 N/mm ²	w/w	w/d	0,90										2,00	
		d/d	1,20										2,50	
25 / 20 N/mm ²	w/w	w/d	1,20										3,00	
		d/d	1,50										3,00	

¹⁾ The compressive strength of the single brick must not be less than 80% of the mean compressive strength.

²⁾ For temperature range 72/120°C: $N_{Rk(72/120^\circ C)} = 0,83 \cdot N_{Rk(50/80^\circ C)}$.

fischer injection system FIS V Plus for masonry

Performance

Vertical perforated brick HLz, Characteristic resistance under tension loading

Annex C 70

Appendix 99 / 153

Vertical perforated brick HLz, EN 771-1:2011+A1:2015

Table C71.2: Characteristic resistance to local brick failure or brick edge failure of a single anchor under shear loading

Anchor rod	M6	M8	M6	M8	-	M8	M10	-	M12	M16	
Internal threaded anchor FIS E	-		-		M6	M8	-		M10	M12	-
					11x85				15x85		
Perforated sleeve FIS H K	12x50		12x85		16x85			20x85			
Shear resistance $V_{Rk} = V_{Rk,b} = V_{Rk,c,II} = V_{Rk,c,\perp}$ [kN] depending on the mean compressive strength f_b; Installation and use condition w/w, w/d, d/d; (temperature range 50/80°C and 72/120°C)											
Mean compressive strength / Min. compressive strength single brick ¹⁾	Use conditions										
7,5 / 6 N/mm ²	w/w	w/d	1,2		1,2						
	d/d										
10 / 8 N/mm ²	w/w	w/d	1,5		1,5						
	d/d										
15 / 12 N/mm ²	w/w	w/d	2,0		2,5						
	d/d										
20 / 16 N/mm ²	w/w	w/d	3,0		3,0						
	d/d										
25 / 20 N/mm ²	w/w	w/d	4,0		4,0						
	d/d										

¹⁾ The compressive strength of the single brick must not be less than 80% of the mean compressive strength.

Factor for job site tests and displacements see annex C 123.

fischer injection system FIS V Plus for masonry

Performance

Vertical perforated brick HLz, Characteristic resistance under tension loading

Annex C 71

Appendix 100 / 153

Vertical perforated brick HLz, EN 771-1:2011+A1:2015

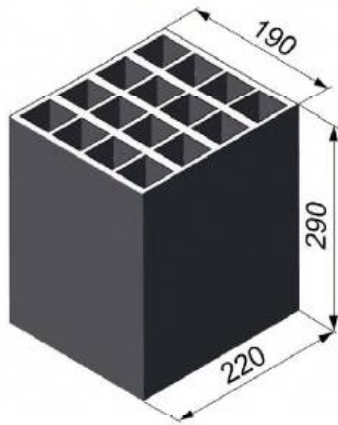

Producer	e.g. Perceram			
Nominal dimensions	[mm]	length L	width W	height H
		220	190	290
Mean gross dry density ρ	[kg/dm ³]	$\geq 0,7$		
Mean compressive strength / Min. compressive strength single brick ¹⁾	[N/mm ²]	7,5 / 6 or 10 / 8 or 12,5 / 10		
Standard or annex	EN 771-1:2011+A1:2015			

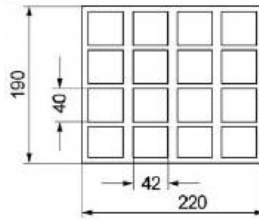

Dimension see also Annex B 18

Table C72.1: Installation parameters
(Pre-positioned anchorage with perforated sleeve FIS H K)

Anchor rod	M6	M8	M6	M8	-	M8	M10	M8	M10	-	M12	M16	M12	M16
Internal threaded anchor FIS E	-		-		M6	M8	-		-		M10	M12	-	
					11x85						15x85			
Perforated sleeve FIS H K	12x50		12x85		16x85			16x130		20x85			20x130	

Anchor rod and internal threaded anchor FIS E with perforated sleeve FIS H K

Max. installation torque $\max T_{inst}$ [Nm]	2													
---	---	--	--	--	--	--	--	--	--	--	--	--	--	--

General installation parameters

Edge distance $C_{min} = C_{cr}$	110													
Spacing $S_{min \parallel} = S_{cr \parallel}$	220													
	$S_{min \perp} = S_{cr \perp}$	290												

Drilling method

Hammer drilling with hard metal hammer drill

¹⁾ The compressive strength of the single brick must not be less than 80% of the mean compressive strength.

Table C72.2: Group factors

Anchor rod	M6	M8	M6	M8	-	M8	M10	M8	M10	-	M12	M16	M12	M16
Internal threaded anchor FIS E	-		-		M6	M8	-		-		M10	M12	-	
					11x85						15x85			
Perforated sleeve FIS H K	12x50		12x85		16x85			16x130		20x85			20x130	

Group factors	$\alpha_{g,N} (S_{min \parallel})$	[-]	2											
	$\alpha_{g,V} (S_{min \parallel})$													
	$\alpha_{g,N} (S_{min \perp})$													
	$\alpha_{g,V} (S_{min \perp})$													

fischer injection system FIS V Plus for masonry

Performance
Vertical perforated brick HLz, dimensions, installation parameters

Annex C 72

Appendix 101 / 153

Vertical perforated brick HLz, EN 771-1:2011+A1:2015

Table C73.1: Installation parameters
(Push through anchorage with perforated sleeve FIS H K)

Anchor rod	M10	M12	M16
Perforated sleeve FIS H K	18x130/200		22x130/200
Anchor rod with perforated sleeve FIS H K			
Max. installation torque $\max T_{inst}$ [Nm]	2		
General installation parameters			
Edge distance $c_{min} = c_{cr}$	110		
Spacing $s_{min \parallel} = s_{cr \parallel}$ [mm]	220		
	$s_{min \perp} = s_{cr \perp}$		
Drilling method			
Hammer drilling with hard metal hammer drill			

Table C73.2: Group factors

Anchor rod	M10	M12	M16
Perforated sleeve FIS H K	18x130/200		22x130/200
Group factors $\alpha_{g,N} (s_{min \parallel})$ $\alpha_{g,V} (s_{min \parallel})$ $\alpha_{g,N} (s_{min \perp})$ $\alpha_{g,V} (s_{min \perp})$	[-]		2

fischer injection system FIS V Plus for masonry

Performance
Vertical perforated brick HLz, dimensions, installation parameters

Annex C 73

Appendix 102 / 153

Vertical perforated brick HLz, EN 771-1:2011+A1:2015

Table C74.1: Characteristic resistance to pull-out failure or brick breakout failure of a single anchor under tension loading (Pre-positioned anchorage)

Anchor rod	M6	M8	M6	M8	-	M8	M10	M8	M10	-	M12	M16	M12	M16
Internal threaded anchor FIS E	-		-		M6	M8	-		-		M10	M12	-	
					11x85						15x85			
Perforated sleeve FIS H K	12x50		12x85		16x85			16x130		20x85			20x130	

Tension resistance $N_{Rk} = N_{Rk,p} = N_{Rk,b} = N_{Rk,p,c} = N_{Rk,b,c}$ [kN] depending on the mean compressive strength f_b ; Installation and use condition w/w, w/d, d/d; (temperature range 50/80°C)²⁾

Mean compressive strength / Min. compressive strength single brick ¹⁾	Use conditions									
7,5 / 6 N/mm ²	w/w w/d	0,3	1,2	1,2		1,5		1,2		1,5
	d/d	0,4	1,5	1,5		1,5		1,5		1,5
10 / 8 N/mm ²	w/w w/d	0,5	1,5	1,5		2,0		1,5		2,0
	d/d	0,5	2,0	2,0		2,5		2,0		2,5
12,5 / 10 N/mm ²	w/w w/d	0,6	2,0	2,0		2,5		2,0		2,5
	d/d	0,6	2,5	2,5		3,0		2,5		3,0

¹⁾ The compressive strength of the single brick must not be less than 80% of the mean compressive strength.

²⁾ For temperature range 72/120°C: $N_{Rk(72/120^\circ C)} = 0,83 \cdot N_{Rk(50/80^\circ C)}$.

Table C74.2: Characteristic resistance to pull-out failure or brick breakout failure of a single anchor under tension loading (Push through anchorage)

Anchor rod	M10		M12		M16	
Perforated sleeve FIS H K	18x130/200				22x130/200	

Tension resistance $N_{Rk} = N_{Rk,p} = N_{Rk,b} = N_{Rk,p,c} = N_{Rk,b,c}$ [kN] depending on the mean compressive strength f_b ; Installation and use condition w/w, w/d, d/d; (temperature range 50/80°C)²⁾

Mean compressive strength / Min. compressive strength single brick ¹⁾	Use conditions		
7,5 / 6 N/mm ²	w/w w/d	1,5	
	d/d	1,5	
10 / 8 N/mm ²	w/w w/d	2,0	
	d/d	2,5	
12,5 / 10 N/mm ²	w/w w/d	2,5	
	d/d	3,0	

¹⁾ The compressive strength of the single brick must not be less than 80% of the mean compressive strength.

²⁾ For temperature range 72/120°C: $N_{Rk(72/120^\circ C)} = 0,83 \cdot N_{Rk(50/80^\circ C)}$.

Factor for job site tests and displacements see annex C 123.

fischer injection system FIS V Plus for masonry

Performance

Vertical perforated brick HLz, Characteristic resistance under tension loading

Annex C 74

Appendix 103 / 153

Vertical perforated brick HLz, EN 771-1:2011+A1:2015

Table C75.1: Characteristic resistance to local brick failure or brick edge failure of a single anchor under shear loading (Pre-positioned anchorage)

Anchor rod	M6	M8	M6	M8	-	M8	M10	M8	M10	-	M12	M16	M12	M16
Internal threaded anchor FIS E	-		-		M6	M8	-		-		M10	M12	-	
					11x85						15x85			
Perforated sleeve FIS H K	12x50		12x85		16x85			16x130		20x85			20x130	

Shear resistance $V_{Rk} = V_{Rk,b} = V_{Rk,c,II} = V_{Rk,c,\perp}$ [kN] depending on the mean compressive strength f_b ; Installation and use condition w/w, w/d, d/d; (temperature range 50/80°C and 72/120°C)

Mean compressive strength / Min. compressive strength single brick ¹⁾	Use conditions								
7,5 / 6 N/mm ²	w/w	1,5	1,5	1,5	2,5	1,5	2,0		
	w/d								
10 / 8 N/mm ²	w/w	2,0	2,0	2,0	3,5	2,0	3,0		
	w/d								
12,5 / 10 N/mm ²	w/w	2,5	3,0	3,0	4,5	3,0	3,5		
	w/d								

¹⁾ The compressive strength of the single brick must not be less than 80% of the mean compressive strength.

Table C75.2: Characteristic resistance to local brick failure or brick edge failure of a single anchor under shear loading (Push through anchorage)

Anchor rod	M10	M12	M16
Perforated sleeve FIS H K	18x130/200		22x130/200

Shear resistance $V_{Rk} = V_{Rk,b} = V_{Rk,c,II} = V_{Rk,c,\perp}$ [kN] depending on the mean compressive strength f_b ; Installation and use condition w/w, w/d, d/d; (temperature range 50/80°C and 72/120°C)

Mean compressive strength / Min. compressive strength single brick ¹⁾	Use conditions		
7,5 / 6 N/mm ²	w/w	2,0	
	w/d		
10 / 8 N/mm ²	w/w	3,0	
	w/d		
12,5 / 10 N/mm ²	w/w	3,5	
	w/d		

¹⁾ The compressive strength of the single brick must not be less than 80% of the mean compressive strength.

Factor for job site tests and displacements see annex C123.

fischer injection system FIS V Plus for masonry

Performance
Vertical perforated brick HLz, Characteristic resistance under shear loading

Annex C 75

Appendix 104 / 153

Vertical perforated brick HLz, EN 771-1:2011+A1:2015

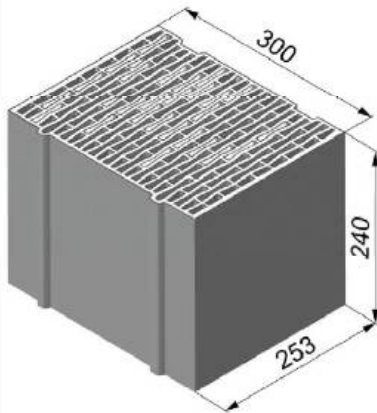

Producer		e.g. Ziegelwerk Brenna		
Nominal dimensions	[mm]	length L	width W	height H
		253	300	240
Mean gross dry density ρ	[kg/dm ³]	≥ 0,8		
Mean compressive strength / Min. compressive strength single brick ¹⁾	[N/mm ²]	2,5 / 2 or 5 / 4 or 8 / 6		
Standard or annex		EN 771-1:2011+A1:2015		

Dimension see also Annex B 18

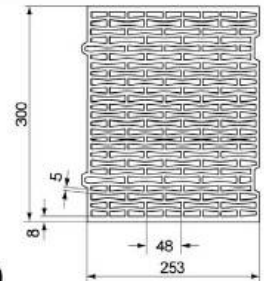

Table C76.1: Installation parameters
(Pre-positioned anchorage with perforated sleeve FIS H K)

Anchor rod	M6	M8	M6	M8	-	M8	M10	M8	M10	-	M12	M16	M12	M16
Internal threaded anchor FIS E	-		-		M6	M8	-		-		M10	M12	-	
					11x85						15x85			
Perforated sleeve FIS H K	12x50		12x85		16x85			16x130		20x85			20x130	

Anchor rod and internal threaded anchor FIS E with perforated sleeve FIS H K

Max. installation torque $\max T_{inst}$ [Nm]	2													
---	---	--	--	--	--	--	--	--	--	--	--	--	--	--

General installation parameters

Edge distance $c_{min} = c_{cr}$	60													
Spacing	$s_{min \parallel} = s_{cr \parallel}$ [mm]													
	255													
	$s_{min \perp} = s_{cr \perp}$													
	240													

Drilling method

Hammer drilling with hard metal hammer drill

¹⁾ The compressive strength of the single brick must not be less than 80% of the mean compressive strength.

Table C76.2: Group factors

Anchor rod	M6	M8	M6	M8	-	M8	M10	M8	M10	-	M12	M16	M12	M16
Internal threaded anchor FIS E	-		-		M6	M8	-		-		M10	M12	-	
					11x85						15x85			
Perforated sleeve FIS H K	12x50		12x85		16x85			16x130		20x85			20x130	

Group factors	$\alpha_{g,N} (s_{min \parallel})$	[-]	2											
	$\alpha_{g,V} (s_{min \parallel})$													
	$\alpha_{g,N} (s_{min \perp})$													
	$\alpha_{g,V} (s_{min \perp})$													

fischer injection system FIS V Plus for masonry

Performance
Vertical perforated brick HLz, dimensions, installation parameters

Annex C 76

Appendix 105 / 153

Vertical perforated brick HLz, EN 771-1:2011+A1:2015

Table C77.1: Installation parameters
(Push through anchorage with perforated sleeve FIS H K)

Anchor rod		M10	M12	M16
Perforated sleeve FIS H K		18x130/200		22x130/200
Anchor rod with perforated sleeve FIS H K				
Max. installation torque	T_{inst}	[Nm]	2	
General installation parameters				
Edge distance	$c_{min} = c_{cr}$		60	
Spacing	$s_{min \parallel} = s_{cr \parallel}$	[mm]	255	
	$s_{min \perp} = s_{cr \perp}$		240	
Drilling method				
Hammer drilling with hard metal hammer drill				

Table C77.2: Group factors

Anchor rod		M10	M12	M16
Perforated sleeve FIS H K		18x130/200		22x130/200
Group factors	$\alpha_{g,N}(s_{min \parallel})$	[-]	2	
	$\alpha_{g,V}(s_{min \parallel})$			
	$\alpha_{g,N}(s_{min \perp})$			
	$\alpha_{g,V}(s_{min \perp})$			

fischer injection system FIS V Plus for masonry

Performance
Vertical perforated brick HLz, dimensions, installation parameters

Annex C 77

Appendix 106 / 153

Vertical perforated brick HLz, EN 771-1:2011+A1:2015

Table C78.1: Characteristic resistance to pull-out failure or brick breakout failure of a single anchor under tension loading (Pre-positioned anchorage)

Anchor rod	M6	M8	M6	M8	-	M8	M10	M8	M10	-	M12	M16	M12	M16
Internal threaded anchor FIS E	-		-		M6 M8	-		-		M10 M12	-		-	
Perforated sleeve FIS H K	12x50		12x85		16x85			16x130		20x85			20x130	
Tension resistance $N_{Rk} = N_{Rk,p} = N_{Rk,b} = N_{Rk,p,c} = N_{Rk,b,c}$ [kN] depending on the mean compressive strength f_b ; Installation and use condition w/w, w/d, d/d; (temperature range 50/80°C) ²⁾														
Mean compressive strength / Min. compressive strength single brick ¹⁾	Use conditions													
2,5 / 2 N/mm ²	w/w	w/d	- ³⁾	0,50	0,50	0,40	0,50	0,40	0,50	0,50	0,50	0,50	0,50	0,40
	d/d		0,30	0,50	0,50	0,50	0,50	0,50	0,50	0,50	0,50	0,50	0,50	0,50
5 / 4 N/mm ²	w/w	w/d	0,50	0,90	0,90	0,90	0,90	0,90	0,90	0,90	0,90	0,90	0,90	0,90
	d/d		0,60	0,90	0,90	0,90	0,90	0,90	0,90	0,90	0,90	0,90	0,90	0,90
8 / 6 N/mm ²	w/w	w/d	0,75	1,50	1,50	1,20	1,50	1,20	1,50	1,50	1,50	1,50	1,50	1,20
	d/d		0,90	1,50	1,50	1,50	1,50	1,50	1,50	1,50	1,50	1,50	1,50	1,50

¹⁾ The compressive strength of the single brick must not be less than 80% of the mean compressive strength.

²⁾ For temperature range 72/120°C: $N_{Rk(72/120^\circ C)} = 0,83 \cdot N_{Rk(50/80^\circ C)}$.

³⁾ No performance assessed.

Table C78.2: Characteristic resistance to pull-out failure or brick breakout failure of a single anchor under tension loading (Push through anchorage)

Anchor rod	M10	M12	M16
Perforated sleeve FIS H K	18x130/200		22x130/200
Tension resistance $N_{Rk} = N_{Rk,p} = N_{Rk,b} = N_{Rk,p,c} = N_{Rk,b,c}$ [kN] depending on the mean compressive strength f_b ; Installation and use condition w/w, w/d, d/d; (temperature range 50/80°C) ²⁾			
Mean compressive strength / Min. compressive strength single brick ¹⁾	Use conditions		
2,5 / 2 N/mm ²	w/w	w/d	0,4
	d/d		0,5
5 / 4 N/mm ²	w/w	w/d	0,9
	d/d		0,9
8 / 6 N/mm ²	w/w	w/d	1,2
	d/d		1,5

¹⁾ The compressive strength of the single brick must not be less than 80% of the mean compressive strength.

²⁾ For temperature range 72/120°C: $N_{Rk(72/120^\circ C)} = 0,83 \cdot N_{Rk(50/80^\circ C)}$.

Factor for job site tests and displacements see annex C 123.

fischer injection system FIS V Plus for masonry

Performance
Vertical perforated brick HLz, Characteristic resistance under tension loading

Annex C 78

Appendix 107 / 153

Vertical perforated brick HLz, EN 771-1:2011+A1:2015

Table C79.1: Characteristic resistance to local brick failure or brick edge failure of a single anchor under shear loading (Pre-positioned anchorage)

Anchor rod	M6	M8	M6	M8	-	M8	M10	M8	M10	-	M12	M16	M12	M16
Internal threaded anchor FIS E	-		-		M6	M8	-		-		M10	M12	-	
Perforated sleeve FIS H K	12x50		12x85		16x85			16x130		20x85			20x130	

Shear resistance $V_{Rk} = V_{Rk,b} = V_{Rk,c,II} = V_{Rk,c,I}$ [kN] depending on the mean compressive strength f_b ; Installation and use condition w/w, w/d, d/d; (temperature range 50/80°C and 72/120°C)

Mean compressive strength / Min. compressive strength single brick ¹⁾	Use conditions		
2,5 / 2 N/mm ²	w/w w/d	0,5	0,6
	d/d		
5 / 4 N/mm ²	w/w w/d	0,9	1,2
	d/d		
8 / 6 N/mm ²	w/w w/d	1,5	1,5
	d/d		

¹⁾ The compressive strength of the single brick must not be less than 80% of the mean compressive strength.

Table C79.2: Characteristic resistance to local brick failure or brick edge failure of a single anchor under shear loading (Push through anchorage)

Anchor rod	M10	M12	M16
Perforated sleeve FIS H K	18x130/200		22x130/200

Shear resistance $V_{Rk} = V_{Rk,b} = V_{Rk,c,II} = V_{Rk,c,I}$ [kN] depending on the mean compressive strength f_b ; Installation and use condition w/w, w/d, d/d; (temperature range 50/80°C and 72/120°C)

Mean compressive strength / Min. compressive strength single brick ¹⁾	Use conditions		
2,5 / 2 N/mm ²	w/w w/d	0,5	0,6
	d/d		
5 / 4 N/mm ²	w/w w/d	0,9	1,2
	d/d		
8 / 6 N/mm ²	w/w w/d	1,5	1,5
	d/d		

¹⁾ The compressive strength of the single brick must not be less than 80% of the mean compressive strength.

Factor for job site tests and displacements see annex C 123.

fischer injection system FIS V Plus for masonry

Performance
Vertical perforated brick HLz, Characteristic resistance under shear loading

Annex C 79

Appendix 108 / 153

**Vertical perforated brick HLz, Porotherm W 44, filled with mineral wool,
EN 771-1:2011+A1:2015**

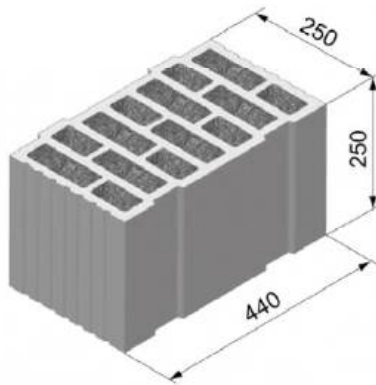

Producer	e.g. Wienerberger		
Nominal dimensions [mm]	length L	width W	height H
	250	440	250
Mean gross dry density ρ [kg/dm ³]	0,7		
Mean compressive strength / Min. compressive strength single brick ¹⁾ [N/mm ²]	8 / 6 or 10 / 8 or 12,5 / 10		
Standard or annex	EN 771-1:2011+A1:2015		

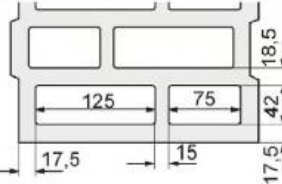

Dimension see also Annex B 18

Table C80.1: Installation parameters
(Pre-positioned anchorage with perforated sleeve FIS H K)

Anchor rod	M6	M8	M6	M8	-	M8	M10	M8	M10	-	M12	M16	M12	M16	M12	M16
Internal threaded anchor FIS E	-	-	M6	M8					M10	M12						
			11x85						15x85							
Perforated sleeve FIS H K	12x50		12x85		16x85			16x130		20x85			20x130		20x200	
Anchor rod and internal threaded anchor FIS E with perforated sleeve FIS H K																
Max. installation torque max T_{inst} [Nm]	2				5			2		5			6			
General installation parameters																
Edge distance $c_{min} = c_{cr}$	60															
Spacing $s_{min II}$	80															
$s_{scr II}$ [mm]	250															
$s_{min \perp}$	80															
$s_{scr \perp}$	250															
Drilling method																
Rotary drilling with carbide drill																

Table C80.2: Group factors

Anchor rod	M6	M8	M6	M8	-	M8	M10	M8	M10	-	M12	M16	M12	M16	M12	M16
Internal threaded anchor FIS E	-	-	M6	M8					M10	M12						
			11x85						15x85							
Perforated sleeve FIS H K	12x50		12x85		16x85			16x130		20x85			20x130		20x200	
Group factors $\alpha_{g,N} (s_{min II})$	1,3															
$\alpha_{g,V} (s_{min II})$	1,3															
$\alpha_{g,N} (s_{min \perp})$	0,8															
$\alpha_{g,V} (s_{min \perp})$	1,3															

fischer injection system FIS V Plus for masonry

Performance
Vertical perforated brick HLz, Porotherm W 44, filled with mineral wool;
dimensions, installation parameters

Annex C 80

Appendix 109 / 153

**Vertical perforated brick HLz, PoroTherm W 44, filled with mineral wool,
EN 771-1:2011+A1:2015**

Table C81.1: Installation parameters
(Push through anchorage with perforated sleeve FIS H K)

Anchor rod		M10	M12	M16
Perforated sleeve FIS H K		18x130/200		22x130/200
Anchor rod with perforated sleeve FIS H K				
Max. installation torque	max T_{inst} [Nm]	5	6	
General installation parameters				
Edge distance	$c_{min} = c_{cr}$	60		
	$s_{min \parallel}$	80		
	$s_{cr \parallel}$ [mm]	250		
	$s_{min \perp}$	80		
	$s_{cr \perp}$	250		
Drilling method				
Rotary drilling with carbide drill				

Table C81.2: Group factors

Anchor rod		M10	M12	M16
Perforated sleeve FIS H K		18x130/200		22x130/200
Group factors	$\alpha_{g,N}(s_{min \parallel})$	[-]	1,3	
	$\alpha_{g,V}(s_{min \parallel})$		1,3	
	$\alpha_{g,N}(s_{min \perp})$		0,8	
	$\alpha_{g,V}(s_{min \perp})$		1,3	

fischer injection system FIS V Plus for masonry

Performance
Vertical perforated brick HLz, PoroTherm W 44, filled with mineral wool;
dimensions, installation parameters

Annex C 81

Appendix 110 / 153

**Vertical perforated brick HLz, Porotherm W 44, filled with mineral wool,
EN 771-1:2011+A1:2015**

Table C82.1: Characteristic resistance to pull-out failure or brick breakout failure of a single anchor under tension loading (Pre-positioned anchorage)

Anchor rod	M6	M8	M6	M8	-	M8	M10	M8	M10	-	M12	M16	M12	M16	M12	M16	
Internal threaded anchor FIS E	-		-		M6	M8	-		-		M10	M12	-		-		
					11x85						15x85						
Perforated sleeve FIS H K	12x50		12x85		16x85			16x130			20x85			20x130		20x200	

Tension resistance $N_{Rk} = N_{Rk,p} = N_{Rk,b} = N_{Rk,p,c} = N_{Rk,b,c}$ [kN] depending on the mean compressive strength f_b ; Installation and use condition w/w, w/d, d/d; (temperature range 50/80°C)²⁾

Mean compressive strength / Min. compressive strength single brick ¹⁾	Use conditions										
	w/w	w/d									
8 / 6 N/mm ²	w/w	w/d	0,75	1,50	1,20			1,50			2,50
	d/d		0,90	1,50	1,20			1,50			2,50
10 / 8 N/mm ²	w/w	w/d	0,90	1,50	1,20			1,50			2,50
	d/d		0,90	2,00	1,50			2,00			3,00
12,5 / 10 N/mm ²	w/w	w/d	0,90	2,00	1,50			2,00			3,00
	d/d		1,20	2,00	1,50			2,00			3,50

- 1) The compressive strength of the single brick must not be less than 80% of the mean compressive strength.
2) For temperature range 72/120°C: $N_{Rk(72/120^\circ C)} = 0,83 \cdot N_{Rk(50/80^\circ C)}$.

Table C82.2: Characteristic resistance to pull-out failure or brick breakout failure of a single anchor under tension loading (Push through anchorage)

Anchor rod	M10		M12		M16	
Perforated sleeve FIS H K	18x130/200				22x130/200	

Tension resistance $N_{Rk} = N_{Rk,p} = N_{Rk,b} = N_{Rk,p,c} = N_{Rk,b,c}$ [kN] depending on the mean compressive strength f_b ; Installation and use condition w/w, w/d, d/d; (temperature range 50/80°C)²⁾

Mean compressive strength / Min. compressive strength single brick ¹⁾	Use conditions					
	w/w	w/d				
8 / 6 N/mm ²	w/w	w/d			1,5	
	d/d				1,5	
10 / 8 N/mm ²	w/w	w/d			1,5	
	d/d				2,0	
12,5 / 10 N/mm ²	w/w	w/d			2,0	
	d/d				2,0	

- 1) The compressive strength of the single brick must not be less than 80% of the mean compressive strength.
2) For temperature range 72/120°C: $N_{Rk(72/120^\circ C)} = 0,83 \cdot N_{Rk(50/80^\circ C)}$.

Factor for job site tests and displacements see annex C 123.

fischer injection system FIS V Plus for masonry

Performance
Vertical perforated brick HLz, Porotherm W 44, filled with mineral wool,
Characteristic resistance under tension loading

Annex C 82
Appendix 111 / 153

**Vertical perforated brick HLz, Porotherm W 44, filled with mineral wool,
EN 771-1:2011+A1:2015**

Table C83.1: Characteristic resistance to local brick failure or brick edge failure of a single anchor under shear loading (Pre-positioned anchorage)

Anchor rod	M6	M8	M6	M8	-	M8	M10	M8	M10	-	M12	M16	M12	M16	M12	M16
Internal threaded anchor FIS E	-		-		M6	M8	-		-		M10	M12	-		-	
					11x85						15x85					
Perforated sleeve FIS H K	12x50		12x85		16x85			16x130			20x85		20x130		20x200	

Shear resistance $V_{Rk} = V_{Rk,b} = V_{Rk,c,II} = V_{Rk,c,I}$ [kN] depending on the mean compressive strength f_b ;
Installation and use condition w/w, w/d, d/d; (temperature range 50/80°C and 72/120°C)

Mean compressive strength / Min. compressive strength single brick ¹⁾	Use conditions												
		w/w	w/d	d/d									
8 / 6 N/mm ²		w/w	w/d	0,9		1,2		0,9		1,2		1,2	
		d/d											
10 / 8 N/mm ²		w/w	w/d	0,9		1,5		0,9		1,5		1,2	
		d/d											
12,5 / 10 N/mm ²		w/w	w/d	1,2		1,5		1,2		1,5		1,5	
		d/d											

¹⁾ The compressive strength of the single brick must not be less than 80% of the mean compressive strength.

Table C83.2: Characteristic resistance to local brick failure or brick edge failure of a single anchor under shear loading (Push through anchorage)

Anchor rod	M10	M12	M16
Perforated sleeve FIS H K	18x130/200		22x130/200

Shear resistance $V_{Rk} = V_{Rk,b} = V_{Rk,c,II} = V_{Rk,c,I}$ [kN] depending on the mean compressive strength f_b ;
Installation and use condition w/w, w/d, d/d; (temperature range 50/80°C and 72/120°C)

Mean compressive strength / Min. compressive strength single brick ¹⁾	Use conditions						
		w/w	w/d	d/d			
8 / 6 N/mm ²		w/w	w/d	1,2		1,2	
		d/d					
10 / 8 N/mm ²		w/w	w/d	1,5		1,5	
		d/d					
12,5 / 10 N/mm ²		w/w	w/d	1,5		1,5	
		d/d					

¹⁾ The compressive strength of the single brick must not be less than 80% of the mean compressive strength.

Factor for job site tests and displacements see annex C 123.

fischer injection system FIS V Plus for masonry

Performance

Vertical perforated brick HLz, Porotherm W 44, filled with mineral wool;
Characteristic resistance under shear loading

Annex C 83

Appendix 112 / 153

Vertical perforated brick HLz, EN 771-1:2011+A1:2015

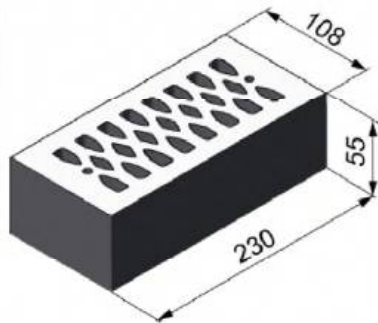

Producer	e.g. Wienerberger.			
Nominal dimensions	[mm]	length L	width W	height H
		230	108	55
Mean gross dry density ρ	[kg/dm ³]	≥ 1,4		
Mean compressive strength / Min. compressive strength single brick ¹⁾	[N/mm ²]	2,5 / 2 or 5 / 4 or 8 / 6 or 10 / 8		
Standard or annex	EN 771-1:2011+A1:2015			

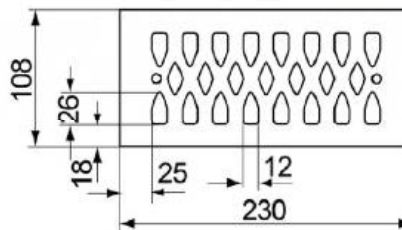

Dimension see also Annex B 18

Table C84.1: Installation parameters

Anchor rod	M6	M8	M6	M8	-	M8	M10	-	M12	M16
Internal threaded anchor FIS E	-		-		M6	M8	-		M10	M12
					11x85				15x85	
Perforated sleeve FIS H K	12x50		12x85		16x85			20x85		

Anchor rod and internal threaded anchor FIS E with perforated sleeve FIS H K

Max. installation torque	max T_{inst} [Nm]	2
--------------------------	---------------------	---

General installation parameters

Edge distance	$c_{min} = c_{cr}$	60
	$s_{min II}$	80
	$s_{cr II}$ [mm]	230
	$s_{min \perp}$	60
	$s_{cr \perp}$	60

Drilling method

Hammer drilling with hard metal hammer drill

¹⁾ The compressive strength of the single brick must not be less than 80% of the mean compressive strength.

Table C84.2: Group factors

Anchor rod	M6	M8	M6	M8	-	M8	M10	-	M12	M16
Internal threaded anchor FIS E	-		-		M6	M8	-		M10	M12
					11x85				15x85	
Perforated sleeve FIS H K	12x50		12x85		16x85			20x85		

Group factors	$\alpha_{g,N} (s_{min II})$	[-]	2
	$\alpha_{g,V} (s_{min II})$		
	$\alpha_{g,N} (s_{min \perp})$		
	$\alpha_{g,V} (s_{min \perp})$		

fischer injection system FIS V Plus for masonry

Performance
Vertical perforated brick HLz, dimensions, installation parameters

Annex C 84

Appendix 113 / 153

Vertical perforated brick HLz, EN 771-1:2011+A1:2015

Table C85.1: Characteristic resistance to pull-out failure or brick breakout failure of a single anchor under tension loading ¹⁾

Anchor rod	M6	M8	M6	M8	-	M8	M10	-	M12	M16	
Internal threaded anchor FIS E	-		-		M6	M8	-		M10	M12	-
					11x85				15x85		
Perforated sleeve FIS H K	12x50		12x85		16x85			20x85			
Tension resistance $N_{Rk} = N_{Rk,p} = N_{Rk,b} = N_{Rk,p,c} = N_{Rk,b,c}$ [kN] depending on the mean compressive strength f_b ; Installation and use condition w/w, w/d, d/d; (temperature range 50/80°C) ³⁾											
Mean compressive strength / Min. compressive strength single brick ²⁾	Use conditions										
2,5 / 2 N/mm ²	w/w	w/d	0,30		0,90		0,75		0,50		
	d/d		0,30		0,90		0,90		0,60		
5 / 4 N/mm ²	w/w	w/d	0,60		1,50		1,50		0,90		
	d/d		0,75		2,00		1,50		1,20		
8 / 6 N/mm ²	w/w	w/d	0,90		2,50		2,50		1,50		
	d/d		0,90		3,00		2,50		1,50		
10 / 8 N/mm ²	w/w	w/d	1,20		3,50		3,00		2,00		
	d/d		1,50		4,00		3,50		2,50		

¹⁾ If the fixing is in a solid area, for w/w, the characteristic value shall be reduced with the factor 0,64.

²⁾ The compressive strength of the single brick must not be less than 80% of the mean compressive strength.

³⁾ For temperature range 72/120°C: $N_{Rk(72/120^\circ C)} = 0,83 \cdot N_{Rk(50/80^\circ C)}$.

Table C85.2: Characteristic resistance to local brick failure or brick edge failure of a single anchor under shear loading

Anchor rod	M6	M8	M6	M8	-	M8	M10	-	M12	M16	
Internal threaded anchor FIS E	-		-		M6	M8	-		M10	M12	-
					11x85				15x85		
Perforated sleeve FIS H K	12x50		12x85		16x85			20x85			
Shear resistance $V_{Rk} = V_{Rk,b} = V_{Rk,c,II} = V_{Rk,c,\perp}$ [kN] depending on the mean compressive strength f_b ; Installation and use condition w/w, w/d, d/d; (temperature range 50/80°C and 72/120°C)											
Mean compressive strength / Min. compressive strength single brick ¹⁾	Use conditions										
2,5 / 2 N/mm ²	w/w	w/d							0,4		
	d/d						0,6				
5 / 4 N/mm ²	w/w	w/d							0,9		
	d/d						1,2				
8 / 6 N/mm ²	w/w	w/d							1,2		
	d/d						1,5				
10 / 8 N/mm ²	w/w	w/d							1,5		
	d/d						2,5				

¹⁾ The compressive strength of the single brick must not be less than 80% of the mean compressive strength. Factor for job site tests and displacements see annex C123.

fischer injection system FIS V Plus for masonry

Performance

Vertical perforated brick HLz, Characteristic resistance under tension and shear loading

Annex C 85

Appendix 114 / 153

Vertical perforated brick filled with mineral wool, EN 771-1:2011+A1:2015

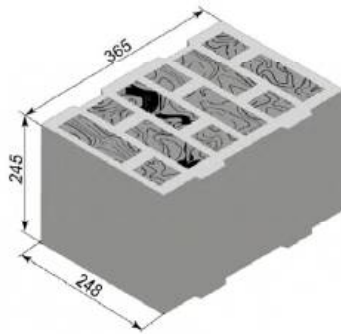

Producer	e.g. Wienerberger			
Nominal dimensions	[mm]	length L	width W	height H
		≥ 365	≥ 248	≥ 245
Mean gross dry density ρ	[kg/dm ³]	0,6		
Mean compressive strength / Min. compressive strength single brick ¹⁾	[N/mm ²]	10 / 8		
Standard or annex	EN 771-1:2011+A1:2015			

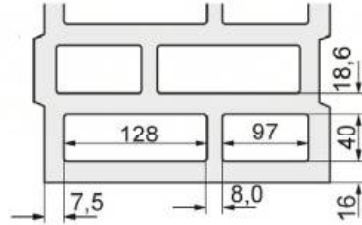

Dimension see also Annex B 19

Table C86.1: Installation parameters
(Pre-positioned anchorage with perforated sleeve FIS H K)

Anchor rod	M6	M8	-	M8	M10	M8	M10	-	M12	M16	M12	M16
Internal threaded anchor FIS E	-		M6	M8	-		-		M10	M12	-	
			11x85						15x85			
Perforated sleeve FIS H K	12x85		16x85			16x130		20x85			20x130	

Anchor rod and internal threaded anchor FIS E with perforated sleeve FIS H K

Max. installation torque	max T_{inst} [Nm]	2	4
--------------------------	---------------------	---	---

General installation parameters

Edge distance	$c_{min} = C_{cr}$	100
Spacing	$s_{min \parallel}$	250
	$s_{cr \parallel}$ [mm]	
	$s_{min \perp}$	245
	$s_{cr \perp}$	

Drilling method

Hammer drilling with hard metal hammer drill

¹⁾ The compressive strength of the single brick must not be less than 80% of the mean compressive strength.

Table C86.2: Group factors

Anchor rod	M6	M8	M8	M10	M8	M10	M12	M16	M12	M16
Perforated sleeve FIS H K	12x85		16x85		16x130		20x85		20x130	
Group factors	$\alpha_{g,N}(s_{min \parallel}) =$ $\frac{\alpha_{g,V}(s_{min \parallel})}{\alpha_{g,N}(s_{min \perp})} =$ $\alpha_{g,V}(s_{min \perp})$		[-]		2					

fischer injection system FIS V Plus for masonry

Performance
Vertical perforated brick filled with mineral wool, dimensions, installation parameters

Annex C 86

Appendix 115 / 153

Vertical perforated brick filled with mineral wool, EN 771-1:2011+A1:2015

Table C87.1: Installation parameters
(Push through anchorage with perforated sleeve FIS H K)

Anchor rod	M10	M12	M16
Perforated sleeve FIS H K	18x130/200		22x130/200
Anchor rod with perforated sleeve FIS H K			
Max. installation torque	$\max T_{inst}$ [Nm]	4	
General installation parameters			
Edge distance	$c_{min} = c_{ef}$	100	
Spacing	$s_{min \parallel}$	250	
	$s_{cr \parallel}$ [mm]		
	$s_{min \perp}$	245	
	$s_{cr \perp}$		
Drilling method			
Hammer drilling with hard metal hammer drill			

Table C87.2: Group factors

Anchor rod	M10	M12	M16
Perforated sleeve FIS H K	18x130/200		22x130/200
Group factors	$\alpha_{g,N} (s_{min \parallel})$	$\alpha_{g,V} (s_{min \parallel})$	2
	$\alpha_{g,N} (s_{min \perp})$	$\alpha_{g,V} (s_{min \perp})$	

fischer injection system FIS V Plus for masonry

Performance
Vertical perforated brick filled with mineral wool, dimensions, installation parameters

Annex C 87
Appendix 116 / 153

Vertical perforated brick filled with mineral wool, EN 771-1:2011+A1:2015

Table C88.1: Characteristic resistance to pull-out failure or brick breakout failure of a single anchor under tension loading (Pre-positioned anchorage)

Anchor rod	M6	M8	-	M8	M10	M8	M10	-	M12	M16	M12	M16	M12	M16
Internal threaded anchor FIS E	-		M6	M8	-		-		M10	M12	-		-	
			11x85						15x85					
Perforated sleeve FIS H K	12x85		16x85		16x130		20x85		20x130		20x200			

Tension resistance $N_{Rk} = N_{Rk,p} = N_{Rk,b} = N_{Rk,p,c} = N_{Rk,b,c}$ [kN] depending on the mean compressive strength f_b ; Installation and use condition w/w, d/d; (temperature range 50/80°C)²⁾

Mean compressive strength / Min. compressive strength single brick ¹⁾	Use conditions								
10 / 8 N/mm ²	w/w	2	1,5	2,5		2,0		2,0	3,0
	d/d	2	2,0	3,0		2,0		2,0	3,0

¹⁾ The compressive strength of the single brick must not be less than 80% of the mean compressive strength.

²⁾ For temperature range 72/120°C no performance assessed.

Table C88.2: Characteristic resistance to pull-out failure or brick breakout failure of a single anchor under tension loading (Push through anchorage)

Anchor rod	M10	M12	M16
Perforated sleeve FIS H K	18x130/200		22x130/200

Tension resistance $N_{Rk} = N_{Rk,p} = N_{Rk,b} = N_{Rk,p,c} = N_{Rk,b,c}$ [kN] depending on the mean compressive strength f_b ; Installation and use condition w/w, d/d; (temperature range 50/80°C)²⁾

Mean compressive strength / Min. compressive strength single brick ¹⁾	Use conditions		
10 / 8 N/mm ²	w/w	1.5	
	d/d	2,0	

¹⁾ The compressive strength of the single brick must not be less than 80% of the mean compressive strength.

²⁾ For temperature range 72/120°C no performance assessed.

Factor for job site tests and displacements see annex C 123.

fischer injection system FIS V Plus for masonry

Performance

Vertical perforated brick filled with mineral wool, Characteristic resistance under tension loading

Annex C 88

Appendix 117 / 153

Vertical perforated brick filled with mineral wool, EN 771-1:2011+A1:2015

Table C89.1: Characteristic resistance to local brick failure or brick edge failure of a single anchor under shear loading (Pre-positioned anchorage)

Anchor rod	M6	M8	-	M8	M10	M8	M10	-	M12	M16	M12	M16	M12	M16
Internal threaded anchor FIS E	-		M6	M8	-		-		M10	M12	-		-	
			11x85						15x85					
Perforated sleeve FIS H K	12x85		16x85			16x130		20x85			20x130		20x200	

Shear resistance $V_{Rk} = V_{Rk,b} = V_{Rk,c,II} = V_{Rk,c,\perp}$ [kN] depending on the mean compressive strength f_b ; Installation and use condition w/w, d/d; (temperature range 50/80°C)²⁾

Mean compressive strength / Min. compressive strength single brick ¹⁾	Use conditions										
		10 / 8 N/mm²	w/w	2,5	3,0	3,0		3,0		1,5	
	d/d	2,5	3,0	3,0		3,0		1,5		1,5	

¹⁾ The compressive strength of the single brick must not be less than 80% of the mean compressive strength.

²⁾ For temperature range 72/120°C no performance assessed.

Table C89.2: Characteristic resistance to local brick failure or brick edge failure of a single anchor under shear loading (Push through anchorage)

Anchor rod	M10	M12	M16
Perforated sleeve FIS H K	18x130/200		22x130/200

Shear resistance $V_{Rk} = V_{Rk,b} = V_{Rk,c,II} = V_{Rk,c,\perp}$ [kN] depending on the mean compressive strength f_b ; Installation and use condition w/w, d/d; (temperature range 50/80°C)²⁾

Mean compressive strength / Min. compressive strength single brick ¹⁾	Use conditions				
		10 / 8 N/mm²	w/w	3,0	
	d/d	3,0		1,5	

¹⁾ The compressive strength of the single brick must not be less than 80% of the mean compressive strength.

²⁾ For temperature range 72/120°C no performance assessed.

Factor for job site tests and displacements see annex C 123.

fischer injection system FIS V Plus for masonry

Performance

Vertical perforated brick filled with mineral wool, Characteristic resistance under shear loading

Annex C 89

Appendix 118 / 153

Vertical perforated brick HLz, EN 771-1:2011+A1:2015

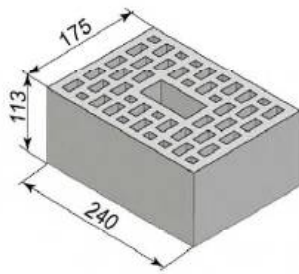

Producer	e.g. Wienerberger			
Nominal dimensions	[mm]	length L	width W	height H
		≥ 240	≥ 175	≥ 113
Mean gross dry density ρ	[kg/dm ³]	0,9		
Mean compressive strength / Min. compressive strength single brick ¹⁾	[N/mm ²]	12,5 / 10		
Standard or annex	EN 771-1:2011+A1:2015			

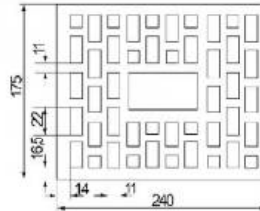

Dimension see also Annex B 19

Table C90.1: Installation parameters
(Pre-positioned anchorage with perforated sleeve FIS H K)

Anchor rod	M6	M8	-	M8	M10	M8	M10	-	M12	M16	M12	M16
Internal threaded anchor FIS E	-		M6	M8	-		-		M10	M12	-	
			11x85						15x85			
Perforated sleeve FIS H K	12x85		16x85			16x130		20x85			20x130	

Anchor rod and internal threaded anchor FIS E with perforated sleeve FIS H K

Max. installation torque	max T _{inst} [Nm]	2	4
--------------------------	----------------------------	---	---

General installation parameters

Edge distance	C _{min} = C _{cr}	100
Spacing	S _{min II}	240
	S _{cr II}	
	S _{min ⊥}	115
	S _{cr ⊥}	

Drilling method

Hammer drilling with hard metal hammer drill

¹⁾ The compressive strength of the single brick must not be less than 80% of the mean compressive strength.

Table C90.2: Group factors

Anchor rod	M6	M8	M8	M10	M8	M10	M12	M16	M12	M16	
Perforated sleeve FIS H K	12x85		16x85		16x130		20x85		20x130		
Group factors	$\alpha_{g,N} (S_{min II}) =$ $\frac{\alpha_{g,V} (S_{min II})}{\alpha_{g,N} (S_{min \perp}) =}$ $\alpha_{g,V} (S_{min \perp})$	[-]	2								

fischer injection system FIS V Plus for masonry

Performance
Vertical perforated brick HLz, dimensions, installation parameters

Annex C 90

Appendix 119 / 153

Vertical perforated brick HLz, EN 771-1:2011+A1:2015

Table C91.1: Installation parameters
(Push through anchorage with perforated sleeve FIS H K)

Anchor rod	M10	M12	M16
Perforated sleeve FIS H K	18x130/200		22x130/200
Anchor rod with perforated sleeve FIS H K			
Max. installation torque $\max T_{inst}$ [Nm]	4		
General installation parameters			
Edge distance $c_{min} = c_{ef}$	100		
Spacing	$s_{min \parallel}$	240	
	$s_{cr \parallel}$ [mm]		
	$s_{min \perp}$	115	
	$s_{cr \perp}$		
Drilling method			
Hammer drilling with hard metal hammer drill			

Table C91.2: Group factors

Anchor rod	M10	M12	M16
Perforated sleeve FIS H K	18x130/200		22x130/200
Group factors	$\alpha_{g,N} (s_{min \parallel})$	$\alpha_{g,V} (s_{min \parallel})$	2
	$\alpha_{g,N} (s_{min \perp})$	$\alpha_{g,V} (s_{min \perp})$	

fischer injection system FIS V Plus for masonry

Performance
Vertical perforated brick HLz, dimensions, installation parameters

Annex C 91
Appendix 120 / 153

Vertical perforated brick HLz, EN 771-1:2011+A1:2015

Table C92.1: Characteristic resistance to pull-out failure or brick breakout failure of a single anchor under tension loading (Pre-positioned anchorage)

Anchor rod	M6	M8	-	M8	M10	M8	M10	-	M12	M16	M12	M16
Internal threaded anchor FIS E	-		M6 M8	-		-		M10 M12	-		-	
			11x85					15x85				
Perforated sleeve FIS H K	12x85		16x85			16x130		20x85			20x130	

Tension resistance $N_{Rk} = N_{Rk,p} = N_{Rk,b} = N_{Rk,p,c} = N_{Rk,b,c}$ [kN] depending on the mean compressive strength f_b ; Installation and use condition w/w, d/d; (temperature range 50/80°C)²⁾

Mean compressive strength / Min. compressive strength single brick ¹⁾	Use conditions					
12,5 / 10 N/mm ²	w/w	3,5	4,0	4,5	4,5	4,0
	d/d	4	4,5	5,0	5,0	4,0

¹⁾ The compressive strength of the single brick must not be less than 80% of the mean compressive strength.

²⁾ For temperature range 72/120°C no performance assessed.

Table C92.2: Characteristic resistance to pull-out failure or brick breakout failure of a single anchor under tension loading (Push through anchorage)

Anchor rod	M10	M12	M16
Perforated sleeve FIS H K	18x130/200		22x130/200

Tension resistance $N_{Rk} = N_{Rk,p} = N_{Rk,b} = N_{Rk,p,c} = N_{Rk,b,c}$ [kN] depending on the mean compressive strength f_b ; Installation and use condition w/w, d/d; (temperature range 50/80°C)²⁾

Mean compressive strength / Min. compressive strength single brick ¹⁾	Use conditions		
12,5 / 10 N/mm ²	w/w	4,5	4,0
	d/d	5,0	4,0

¹⁾ The compressive strength of the single brick must not be less than 80% of the mean compressive strength.

²⁾ For temperature range 72/120°C no performance assessed.

Factor for job site tests and displacements see annex C 123.

fischer injection system FIS V Plus for masonry

Performance
Vertical perforated brick HLz, Characteristic resistance under tension loading

Annex C 92

Appendix 121 / 153

Vertical perforated brick HLz, EN 771-1:2011+A1:2015

Table C93.1: Characteristic resistance to local brick failure or brick edge failure of a single anchor under shear loading (Pre-positioned anchorage)

Anchor rod	M6	M8	-		M8	M10	M8	M10	-		M12	M16	M12	M16
Internal threaded anchor FIS E	-		M6	M8	-		-		M10	M12	-		-	
			11x85						15x85					
Perforated sleeve FIS H K	12x85		16x85				16x130		20x85			20x130		

Shear resistance $V_{Rk} = V_{Rk,b} = V_{Rk,c,II} = V_{Rk,c,\perp}$ [kN] depending on the mean compressive strength f_b ; Installation and use condition w/w, d/d; (temperature range 50/80°C)²⁾

Mean compressive strength / Min. compressive strength single brick ¹⁾	Use conditions														
12,5 / 10 N/mm ²	w/w	4,0	5,5	4,0	5,5	5,5	7,0	5,5	7,0	7,0	6,0	6,0	8,0	6,0	8,0
	d/d	4,0	5,5	4,0	5,5	5,5	7,0	5,5	7,0	7,0	6,0	6,0	8,0	6,0	8,0

¹⁾ The compressive strength of the single brick must not be less than 80% of the mean compressive strength.

²⁾ For temperature range 72/120°C no performance assessed.

Table C93.2: Characteristic resistance to local brick failure or brick edge failure of a single anchor under shear loading (Push through anchorage)

Anchor rod	M10				M12				M16			
Perforated sleeve FIS H K	18x130/200								22x130/200			

Shear resistance $V_{Rk} = V_{Rk,b} = V_{Rk,c,II} = V_{Rk,c,\perp}$ [kN] depending on the mean compressive strength f_b ; Installation and use condition w/w, d/d; (temperature range 50/80°C)²⁾

Mean compressive strength / Min. compressive strength single brick ¹⁾	Use conditions												
12,5 / 10 N/mm ²	w/w	7,0				6,0				8,0			
	d/d	7,0				6,0				8,0			

¹⁾ The compressive strength of the single brick must not be less than 80% of the mean compressive strength.

²⁾ For temperature range 72/120°C no performance assessed.

Factor for job site tests and displacements see annex C 123

fischer injection system FIS V Plus for masonry

Performance
Vertical perforated brick HLz, Characteristic resistance under shear loading

Annex C 93

Appendix 122 / 153

Horizontal perforated brick LLz, EN 771-1:2011+A1:2015

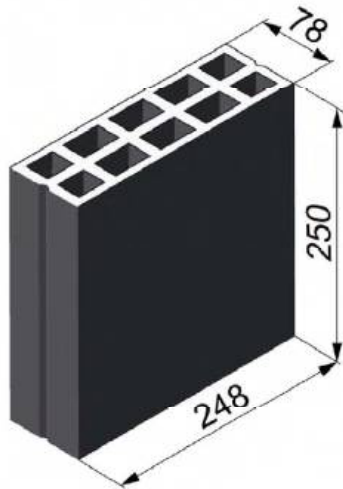

Producer		-		
Nominal dimensions	[mm]	length L	width W	height H
		250	78	248
Mean gross dry density ρ	[kg/dm ³]	≥ 0,7		
Mean compressive strength / Min. compressive strength single brick ¹⁾	[N/mm ²]	2,5 / 2 or 5 / 4 or 8 / 6		
Standard or annex		EN 771-1:2011+A1:2015		

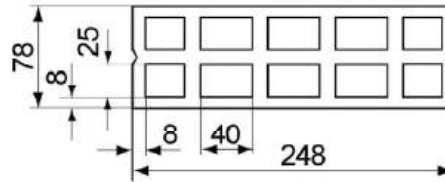

Dimension see also Annex B 19

Table C94.1: Installation parameters

Anchor rod	M6		M8
Perforated sleeve FIS H K	12x50		
Anchor rod with perforated sleeve FIS H K			
Max. installation torque	max T _{inst} [Nm]	2	
General installation parameters			
Edge distance	c _{min} = c _{cr}	100	
Spacing	s _{min II}	75	
	s _{cr II}	250	
	s _{min ⊥} = s _{cr ⊥}	250	
Drilling method			
Hammer drilling with hard metal hammer drill			

¹⁾ The compressive strength of the single brick must not be less than 80% of the mean compressive strength.

Table C94.2: Group factors

Anchor rod	M6		M8
Perforated sleeve FIS H K	12x50		
Group factors	α _{g,N} (s _{min II})	[-]	1,6
	α _{g,V} (s _{min II})		1,1
	α _{g,N} (s _{min ⊥})		2,0
	α _{g,V} (s _{min ⊥})		

fischer injection system FIS V Plus for masonry

Performance
Horizontal perforated brick LLz, dimensions, installation parameters

Annex C 94

Appendix 123 / 153

Horizontal perforated brick LLz, EN 771-1:2011+A1:2015

Table C95.1: Characteristic resistance to pull-out failure or brick breakout failure of a single anchor under tension loading

Anchor rod		M6	M8
Perforated sleeve FIS H K		12x50	
Tension resistance $N_{Rk} = N_{Rk,p} = N_{Rk,b} = N_{Rk,p,c} = N_{Rk,b,c}$ [kN] depending on the mean compressive strength f_b; Installation and use condition w/w, w/d, d/d; (temperature range 50/80°C)²⁾			
Mean compressive strength / Min. compressive strength single brick ¹⁾	Use conditions		
2,5 / 2 N/mm ²	w/w w/d	0,5	
	d/d	0,6	
5 / 4 N/mm ²	w/w w/d	0,9	
	d/d	1,2	
8 / 6 N/mm ²	w/w w/d	1,5	
	d/d	1,5	

¹⁾ The compressive strength of the single brick must not be less than 80% of the mean compressive strength.

²⁾ For temperature range 72/120°C: $N_{Rk(72/120^\circ C)} = 0,83 \cdot N_{Rk(50/80^\circ C)}$.

Table C95.2: Characteristic resistance to local brick failure or brick edge failure of a single anchor under shear loading

Anchor rod		M6	M8
Perforated sleeve FIS H K		12x50	
Shear resistance $V_{Rk} = V_{Rk,b} = V_{Rk,c,II} = V_{Rk,c,I}$ [kN] depending on the mean compressive strength f_b; Installation and use condition w/w, w/d, d/d; (temperature range 50/80°C and 72/120°C)			
Mean compressive strength / Min. compressive strength single brick ¹⁾	Use conditions		
2,5 / 2 N/mm ²	w/w w/d	0,5	
	d/d		
5 / 4 N/mm ²	w/w w/d	0,9	
	d/d		
8 / 6 N/mm ²	w/w w/d	1,5	
	d/d		

¹⁾ The compressive strength of the single brick must not be less than 80% of the mean compressive strength.

Factor for job site tests and displacements see annex C 123.

fischer injection system FIS V Plus for masonry

Performance

Horizontal perforated brick LLz, Characteristic resistance under tension and shear loading

Annex C 95

Appendix 124 / 153

Horizontal perforated brick LLz, EN 771-1:2011+A1:2015

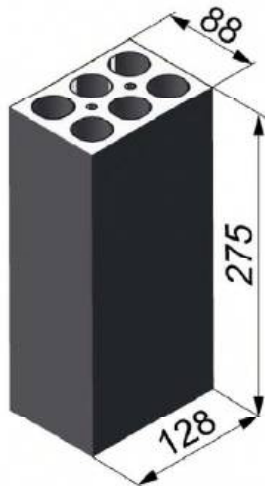

Producer	e.g. Cermanica Farreny S.A.			
Nominal dimensions	[mm]	length L	width W	height H
		275	88	128
Mean gross dry density ρ	[kg/dm ³]	$\geq 0,8$		
Mean compressive strength / Min. compressive strength single brick ¹⁾	[N/mm ²]	2,5 / 2		
Standard or annex	EN 771-1:2011+A1:2015			

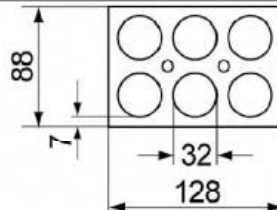

Dimension see also Annex B 19

Table C96.1: Installation parameters

Anchor rod	M6		M8
Perforated sleeve FIS H K	12x50		
Anchor rod with perforated sleeve FIS H K			
Max. installation torque	T_{inst}	[Nm]	2
General installation parameters			
Edge distance	$c_{min} = c_{cr}$		60
Spacing	$s_{min \parallel}$	[mm]	75
	$s_{cr \parallel}$		275
	$s_{min \perp}$		75
	$s_{cr \perp}$		130
	Drilling method		
Hammer drilling with hard metal hammer drill			

¹⁾ The compressive strength of the single brick must not be less than 80% of the mean compressive strength.

Table C96.2: Group factors

Anchor rod	M6		M8
Perforated sleeve FIS H K	12x50		
Group factors	$\alpha_{g,N} (s_{min \parallel})$	[-]	1,3
	$\alpha_{g,V} (s_{min \parallel})$		1,5
	$\alpha_{g,N} (s_{min \perp})$		1,3
	$\alpha_{g,V} (s_{min \perp})$		1,5

fischer injection system FIS V Plus for masonry

Performance
Horizontal perforated brick LLz, dimensions, installation parameters

Annex C 96

Appendix 125 / 153

Horizontal perforated brick LLz, EN 771-1:2011+A1:2015

Table C97.1: Characteristic resistance to pull-out failure or brick breakout failure of a single anchor under tension loading

Anchor rod		M6	M8
Perforated sleeve FIS H K		12x50	
Tension resistance $N_{Rk} = N_{Rk,p} = N_{Rk,b} = N_{Rk,p,c} = N_{Rk,b,c}$ [kN] depending on the mean compressive strength f_b ; Installation and use condition w/w, w/d, d/d; (temperature range 50/80°C) ²⁾			
Mean compressive strength / Min. compressive strength single brick ¹⁾	Use conditions		
2,5 / 2 N/mm ²	w/w w/d	1,5	
	d/d		

¹⁾ The compressive strength of the single brick must not be less than 80% of the mean compressive strength.

²⁾ For temperature range 72/120°C: $N_{Rk(72/120^\circ C)} = 0,83 \cdot N_{Rk(50/80^\circ C)}$.

Table C97.2: Characteristic resistance to local brick failure or brick edge failure of a single anchor under shear loading

Anchor rod		M6	M8
Perforated sleeve FIS H K		12x50	
Shear resistance $V_{Rk} = V_{Rk,b} = V_{Rk,c,II} = V_{Rk,c,\perp}$ [kN] depending on the mean compressive strength f_b ; Installation and use condition w/w, w/d, d/d; (temperature range 50/80°C and 72/120°C)			
Mean compressive strength / Min. compressive strength single brick ¹⁾	Use conditions		
2,5 / 2 N/mm ²	w/w w/d	1,2	
	d/d		

¹⁾ The compressive strength of the single brick must not be less than 80% of the mean compressive strength.

Factor for job site tests and displacements see annex C123.

fischer injection system FIS V Plus for masonry

Performance

Horizontal perforated brick LLz, Characteristic resistance under tension and shear loading

Annex C 97

Appendix 126 / 153

Light-weight concrete hollow block Hbl, EN 771-3:2011+A1:2015

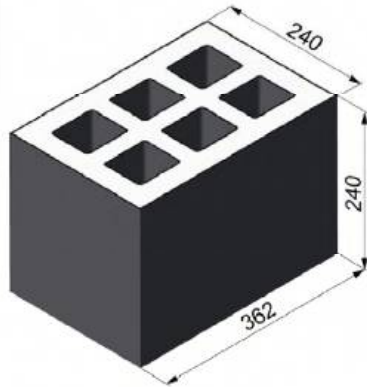

Producer	-			
Nominal dimensions	[mm]	length L	width W	height H
		362	240	240
Mean gross dry density ρ	[kg/dm ³]	$\geq 1,0$		
Mean compressive strength / Min. compressive strength single brick ¹⁾	[N/mm ²]	2,5 / 2 or 5 / 4		
Standard or annex	EN 771-3:2011+A1:2015			

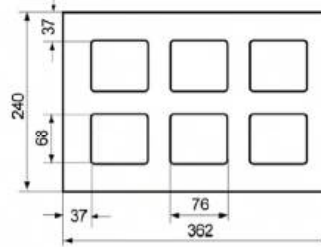

Dimension see also Annex B 19

Table C98.1: Installation parameters
(Pre-positioned anchorage with perforated sleeve FIS H K)

Anchor rod	M6	M8	M6	M8	-	M8	M10	M8	M10	-	M12	M16	M12	M16	M12	M16
Internal threaded anchor FIS E	-	-	M6	M8					M10	M12						
			11x85						15x85							
Perforated sleeve FIS H K	12x50		12x85		16x85			16x130			20x85		20x130		20x200	

Anchor rod and internal threaded anchor FIS E with perforated sleeve FIS H K

Max. installation torque $\max T_{inst}$ [Nm]	2															
General installation parameters																
Edge distance $C_{min} = C_{cr}$	60															
Spacing [mm]	$S_{min \parallel}$	100														
	$S_{cr \parallel}$	362														
	$S_{min \perp} = S_{cr \perp}$	240														

Drilling method

Hammer drilling with hard metal hammer drill

¹⁾ The compressive strength of the single brick must not be less than 80% of the mean compressive strength.

Table C98.2: Group factors

Anchor rod	M6	M8	M6	M8	-	M8	M10	M8	M10	-	M12	M16	M12	M16	M12	M16
Internal threaded anchor FIS E	-	-	M6	M8					M10	M12						
			11x85						15x85							
Perforated sleeve FIS H K	12x50		12x85		16x85			16x130			20x85		20x130		20x200	
Group factors [-]	$\alpha_{g,N} (S_{min \parallel})$	1,2														
	$\alpha_{g,V} (S_{min \parallel})$	1,1														
	$\alpha_{g,N} (S_{min \perp})$	2,0														
	$\alpha_{g,V} (S_{min \perp})$															

fischer injection system FIS V Plus for masonry

Performance
Light-weight concrete hollow block Hbl, dimensions, installation parameters

Annex C 98

Appendix 127 / 153

Light-weight concrete hollow block Hbl, EN 771-3:2011+A1:2015

Table C99.1: Installation parameters
(Push through anchorage with perforated sleeve FIS H K)

Anchor rod		M10	M12	M16
Perforated sleeve FIS H K		18x130/200		22x130/200
Anchor rod with perforated sleeve FIS H K				
Max. installation torque	max T _{inst} [Nm]	2		
General installation parameters				
Edge distance	c _{min} = c _{cr}	60		
Spacing	s _{min II}	100		
	s _{cr II}	362		
	s _{min ⊥} = s _{cr ⊥}	240		
Drilling method				
Hammer drilling with hard metal hammer drill				

Table C99.2: Group factors

Anchor rod		M10	M12	M16
Perforated sleeve FIS H K		18x130/200		22x130/200
Group factors	α _{g,N} (s _{min II})	1,2		
	α _{g,V} (s _{min II})	1,1		
	α _{g,N} (s _{min ⊥})	2,0		
	α _{g,V} (s _{min ⊥})	2,0		

fischer injection system FIS V Plus for masonry

Performance
Light-weight concrete hollow block Hbl, dimensions, installation parameters

Annex C 99

Appendix 128 / 153

Light-weight concrete hollow block Hbl, EN 771-3:2011+A1:2015

Table C100.1: Characteristic resistance to pull-out failure or brick breakout failure of a single anchor under tension loading (Pre-positioned anchorage)

Anchor rod	M6	M8	M6	M8	-	M8	M10	M8	M10	-	M12	M16	M12	M16	M12	M16
Internal threaded anchor FIS E	-		-		M6	M8	-		-		M10	M12	-		-	
Perforated sleeve FIS H K	12x50		12x85		16x85		16x130		20x85		20x130		20x200			
Tension resistance $N_{Rk} = N_{Rk,p} = N_{Rk,b} = N_{Rk,p,c} = N_{Rk,b,c}$ [kN] depending on the mean compressive strength f_b ; Installation and use condition w/w, w/d, d/d; (temperature range 50/80°C) ²⁾																
Mean compressive strength / Min. compressive strength single brick ¹⁾	Use conditions															
2,5 / 2 N/mm ²	w/w	w/d	1,2		1,5						2,5					
	d/d		1,2		1,5						2,5					
5 / 4 N/mm ²	w/w	w/d	2,0		3,0						5,0					
	d/d		2,5		3,0						5,5					

¹⁾ The compressive strength of the single brick must not be less than 80% of the mean compressive strength.

²⁾ For temperature range 72/120°C: $N_{Rk(72/120^\circ C)} = 0,83 \cdot N_{Rk(50/80^\circ C)}$.

Table C100.2: Characteristic resistance to pull-out failure or brick breakout failure of a single anchor under tension loading (Push through anchorage)

Anchor rod	M10		M12		M16	
Perforated sleeve FIS H K	18x130/200				22x130/200	
Tension resistance $N_{Rk} = N_{Rk,p} = N_{Rk,b} = N_{Rk,p,c} = N_{Rk,b,c}$ [kN] depending on the mean compressive strength f_b ; Installation and use condition w/w, w/d, d/d; (temperature range 50/80°C) ²⁾						
Mean compressive strength / Min. compressive strength single brick ¹⁾	Use conditions					
2,5 / 2 N/mm ²	w/w	w/d	1,5			
	d/d		1,5			
5 / 4 N/mm ²	w/w	w/d	3,0			
	d/d		3,0			

¹⁾ The compressive strength of the single brick must not be less than 80% of the mean compressive strength.

²⁾ For temperature range 72/120°C: $N_{Rk(72/120^\circ C)} = 0,83 \cdot N_{Rk(50/80^\circ C)}$.

Factor for job site tests and displacements see annex C123.

fischer injection system FIS V Plus for masonry

Performance

Light-weight concrete hollow block Hbl, Characteristic resistance under tension loading

Annex C 100

Appendix 129 / 153

Light-weight concrete hollow block Hbl, EN 771-3:2011+A1:2015

Table C101.1: Characteristic resistance to local brick failure or brick edge failure of a single anchor under shear loading (Pre-positioned anchorage)

Anchor rod	M6	M8	M6	M8	-	M8	M10	M8	M10	-	M12	M16	M12	M16	M12	M16
Internal threaded anchor FIS E	-		-		M6	M8	-		-		M10	M12	-		-	
Perforated sleeve FIS H K	12x50		12x85		16x85		16x130		20x85		20x130		20x200			

Shear resistance $V_{Rk} = V_{Rk,b} = V_{Rk,c,II} = V_{Rk,c,\perp}$ [kN] depending on the mean compressive strength f_b ; Installation and use condition w/w, w/d, d/d; (temperature range 50/80°C and 72/120°C)

Mean compressive strength / Min. compressive strength single brick ¹⁾	Use conditions	
2,5 / 2 N/mm ²	w/w w/d	0,9
	d/d	
5 / 4 N/mm ²	w/w w/d	2,0
	d/d	

¹⁾ The compressive strength of the single brick must not be less than 80% of the mean compressive strength.

Table C101.2: Characteristic resistance to local brick failure or brick edge failure of a single anchor under shear loading (Push through anchorage)

Anchor rod	M10	M12	M16
Perforated sleeve FIS H K	18x130/200		22x130/200

Shear resistance $V_{Rk} = V_{Rk,b} = V_{Rk,c,II} = V_{Rk,c,\perp}$ [kN] depending on the mean compressive strength f_b ; Installation and use condition w/w, w/d, d/d; (temperature range 50/80°C and 72/120°C)

Mean compressive strength / Min. compressive strength single brick ¹⁾	Use conditions	
2,5 / 2 N/mm ²	w/w w/d	0,9
	d/d	
5 / 4 N/mm ²	w/w w/d	2,0
	d/d	

¹⁾ The compressive strength of the single brick must not be less than 80% of the mean compressive strength.

Factor for job site tests and displacements see annex C 123.

fischer injection system FIS V Plus for masonry

Performance
Light-weight concrete hollow block Hbl, Characteristic resistance under shear loading

Annex C 101

Appendix 130 / 153

Light-weight concrete hollow block Hbl, EN 771-3:2011+A1:2015

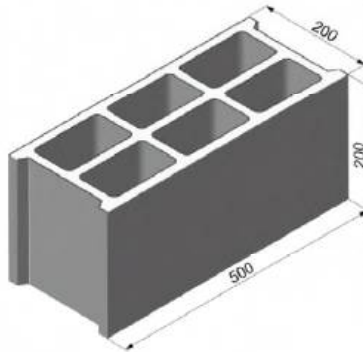

Producer	e.g. Sepa			
Nominal dimensions	[mm]	length L	width W	height H
		500	200	200
Mean gross dry density ρ	[kg/dm ³]	$\geq 1,0$		
Mean compressive strength / Min. compressive strength single brick ¹⁾	[N/mm ²]	2,5 / 2 or 5 / 4 or 8 / 6		
Standard or annex	EN 771-1:2011+A1:2015			

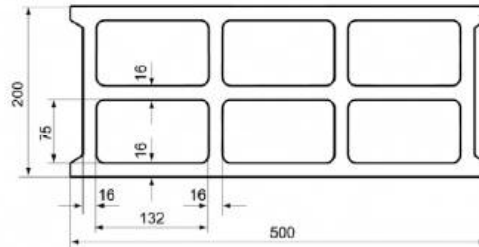

Dimension see also Annex B 19

Table C102.1: Installation parameters

Anchor rod	M6	M8	M6	M8	-	M8	M10	M8	M10	M10	M12	-	M12	M16
Internal threaded anchor FIS E	-		-		M6	M8	-		-		-		M10	M12
					11x85								15x85	
Perforated sleeve FIS H K	12x50		12x85		16x85			16x130		18x130/200		20x85		

Anchor rod and internal threaded anchor FIS E with perforated sleeve FIS H K

Max. installation torque $\max T_{inst}$ [Nm]	1				2									
---	---	--	--	--	---	--	--	--	--	--	--	--	--	--

General installation parameters

Edge distance $c_{min} = c_{cr}$	100													
Spacing $s_{min \parallel} = s_{cr \parallel}$	500													
	$s_{min \perp} = s_{cr \perp}$	200												

Drilling method

Hammer drilling with hard metal hammer drill

¹⁾ The compressive strength of the single brick must not be less than 80% of the mean compressive strength.

Table C102.2: Group factors

Anchor rod	M6	M8	M6	M8	-	M8	M10	M8	M10	M10	M12	-	M12	M16
Internal threaded anchor FIS E	-		-		M6	M8	-		-		-		M10	M12
					11x85								15x85	
Perforated sleeve FIS H K	12x50		12x85		16x85			16x130		18x130/200		20x85		
Group factors	$\alpha_{g,N} (s_{min \parallel})$	[-]	2											
	$\alpha_{g,V} (s_{min \parallel})$													
	$\alpha_{g,N} (s_{min \perp})$													
	$\alpha_{g,V} (s_{min \perp})$													

fischer injection system FIS V Plus for masonry

Performance
Light-weight concrete hollow block Hbl, dimensions, installation parameters

Annex C 102

Appendix 131 / 153

Light-weight concrete hollow block Hbl, EN 771-3:2011+A1:2015

Table C103.1: Characteristic resistance to pull-out failure or brick breakout failure of a single anchor under tension loading

Anchor rod	M6	M8	M6	M8	-	M8	M10	M8	M10	M10	M12	-	M12	M16	
Internal threaded anchor FIS E	-		-		M6	M8	-		-		-		M10	M12	-
					11x85								15x85		
Perforated sleeve FIS H K	12x50		12x85		16x85			16x130		18x130/200		20x85			

Tension resistance $N_{Rk} = N_{Rk,p} = N_{Rk,b} = N_{Rk,p,c} = N_{Rk,b,c}$ [kN] depending on the mean compressive strength f_b ; Installation and use condition w/w, w/d, d/d; (temperature range 50/80°C) ²⁾

Mean compressive strength / Min. compressive strength single brick ¹⁾	use conditions		
2,5 / 2 N/mm ²	w/w	w/d	0,4
	d/d		0,5
5 / 4 N/mm ²	w/w	w/d	0,9
	d/d		0,9
8 / 6 N/mm ²	w/w	w/d	1,2
	d/d		1,5

¹⁾ The compressive strength of the single brick must not be less than 80% of the mean compressive strength.

²⁾ For temperature range 72/120°C: $N_{Rk(72/120°C)} = 0,83 \cdot N_{Rk(50/80°C)}$.

Table C103.2: Characteristic resistance to local brick failure or brick edge failure of a single anchor under shear loading

Anchor rod	M6	M8	M6	M8	-	M8	M10	M8	M10	M10	M12	-	M12	M16	
Internal threaded anchor FIS E	-		-		M6	M8	-		-		-		M10	M12	-
					11x85								15x85		
Perforated sleeve FIS H K	12x50		12x85		16x85			16x130		18x130/200		20x85			

Shear resistance $V_{Rk} = V_{Rk,b} = V_{Rk,c,II} = V_{Rk,c,I}$ [kN] depending on the mean compressive strength f_b ; Installation and use condition w/w, w/d, d/d; (temperature range 50/80°C and 72/120°C)

Mean compressive strength / Min. compressive strength single brick ¹⁾	Use conditions		
2,5 / 2 N/mm ²	w/w	w/d	0,9
	d/d		
5 / 4 N/mm ²	w/w	w/d	1,5
	d/d		
8 / 6 N/mm ²	w/w	w/d	2,5
	d/d		

¹⁾ The compressive strength of the single brick must not be less than 80% of the mean compressive strength.

Factor for job site tests and displacements see annex C 123.

fischer injection system FIS V Plus for masonry

Performance
Light-weight concrete hollow block Hbl,
Characteristic resistance under tension and shear loading

Annex C 103

Appendix 132 / 153

Light-weight concrete hollow block Hbl, EN 771-3:2011+A1:2015

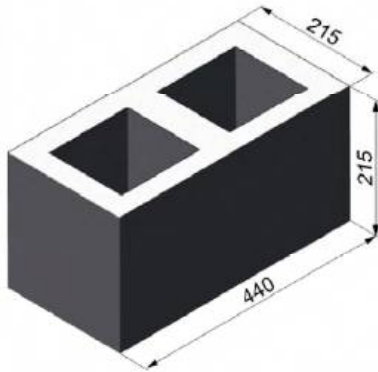

Producer	e.g. Roadstone wood			
Nominal dimensions	[mm]	length L	width W	height H
		440	215	215
Mean gross dry density ρ	[kg/dm ³]	$\geq 1,2$		
Mean compressive strength / Min. compressive strength single brick ¹⁾	[N/mm ²]	5 / 4 or 8 / 6 or 10 / 8 or 12,5 / 10		
Standard or annex	EN 771-3:2011+A1:2015			

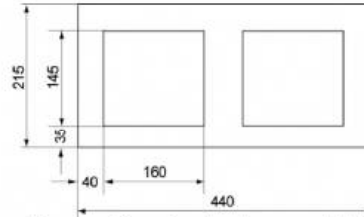

Dimension see also Annex B 20

Table C104.1: Installation parameters
(Pre-positioned anchorage with perforated sleeve FIS H K)

Anchor rod	M6	M8	M6	M8	-	M8	M10	M8	M10	-	M12	M16	M12	M16
Internal threaded anchor FIS E	-		-		M6	M8	-		-		M10	M12	-	
					11x85						15x85			
Perforated sleeve FIS H K	12x50		12x85		16x85				16x130		20x85		20x130	

Anchor rod and internal threaded anchor FIS E with perforated sleeve FIS H K

Max. installation torque $\max T_{inst}$ [Nm]	2													
---	---	--	--	--	--	--	--	--	--	--	--	--	--	--

General installation parameters

Edge distance $c_{min} = c_{cr}$	110														
Spacing	$s_{min \parallel}$	100													
	$s_{cr \parallel}$ [mm]	440													
	$s_{min \perp}$	100													
	$s_{cr \perp}$	215													

Drilling method

Hammer drilling with hard metal hammer drill

¹⁾ The compressive strength of the single brick must not be less than 80% of the mean compressive strength.

Table C104.2: Group factors

Anchor rod	M6	M8	M6	M8	-	M8	M10	M8	M10	-	M12	M16	M12	M16	
Internal threaded anchor FIS E	-		-		M6	M8	-		-		M10	M12	-		
					11x85						15x85				
Perforated sleeve FIS H K	12x50		12x85		16x85				16x130		20x85		20x130		
Group factors	$\alpha_{g,N} (s_{min \parallel})$	1,4													
	$\alpha_{g,V} (s_{min \parallel})$	2,0													
	$\alpha_{g,N} (s_{min \perp})$	1,4													
	$\alpha_{g,V} (s_{min \perp})$	1,2													

fischer injection system FIS V Plus for masonry

Performance
Light-weight concrete hollow block Hbl, dimensions, installation parameters

Annex C 104

Appendix 133 / 153

Light-weight concrete hollow block Hbl, EN 771-3:2011+A1:2015

Table C105.1: Installation parameters
(Push through anchorage with perforated sleeve FIS H K)

Anchor rod		M10	M12	M16
Perforated sleeve FIS H K		18x130/200		22x130/200
Anchor rod with perforated sleeve FIS H K				
Max. installation torque	max T _{inst} [Nm]	2		
General installation parameters				
Edge distance	c _{min} = c _{cr}	110		
Spacing	s _{min}	100		
	s _{cr} [mm]	440		
	s _{min} ⊥	100		
	s _{cr} ⊥	215		

Drilling method

Hammer drilling with hard metal hammer drill

Table C105.2: Group factors

Anchor rod		M10	M12	M16
Perforated sleeve FIS H K		18x130/200		22x130/200
Group factors	α _{g,N} (s _{min})	[-]	1,4	
	α _{g,V} (s _{min})		2,0	
	α _{g,N} (s _{min} ⊥)		1,4	
	α _{g,V} (s _{min} ⊥)		1,2	

fischer injection system FIS V Plus for masonry

Performance
Light-weight concrete hollow block Hbl, dimensions, installation parameters

Annex C 105

Appendix 134 / 153

Light-weight concrete hollow block Hbl, EN 771-3:2011+A1:2015

Table C106.1: Characteristic resistance to pull-out failure or brick breakout failure of a single anchor under tension loading (Pre-positioned anchorage)

Anchor rod	M6	M8	M6	M8	-	M8	M10	M8	M10	M10	M12	-	M12	M16	
Internal threaded anchor FIS E	-		-		M6	M8	-		-		-		M10	M12	-
					11x85								15x85		
Perforated sleeve FIS H K	12x50		12x85		16x85			16x130		18x130/200		20x85			
Tension resistance $N_{RK} = N_{RK,p} = N_{RK,b} = N_{RK,p,c} = N_{RK,b,c}$ [kN] depending on the mean compressive strength f_b ; Installation and use condition w/w, w/d, d/d; (temperature range 50/80°C) ²⁾															
Mean compressive strength / Min. compressive strength single brick ¹⁾		Use conditions													
5 / 4 N/mm ²	w/w	w/d	0,9				1,2						2,0		
	d/d		1,2				1,5						2,0		
8 / 6 N/mm ²	w/w	w/d	1,5				2,0						3,0		
	d/d		1,5				2,0						3,0		
10 / 8 N/mm ²	w/w	w/d	2,0				2,5						3,5		
	d/d		2,0				3,0						4,0		
12,5 / 10 N/mm ²	w/w	w/d	2,5				3,0						4,5		
	d/d		3,0				3,5						5,0		

¹⁾ The compressive strength of the single brick must not be less than 80% of the mean compressive strength.

²⁾ For temperature range 72/120°C: $N_{RK(72/120^\circ C)} = 0,83 \cdot N_{RK(50/80^\circ C)}$.

Table C106.2: Characteristic resistance to pull-out failure or brick breakout failure of a single anchor under tension loading (Push through anchorage)

Anchor rod	M10		M12		M16	
Perforated sleeve FIS H K	18x130/200				22x130/200	
Tension resistance $N_{RK} = N_{RK,p} = N_{RK,b} = N_{RK,p,c} = N_{RK,b,c}$ [kN] depending on the mean compressive strength f_b ; Installation and use condition w/w, w/d, d/d; (temperature range 50/80°C) ²⁾						
Mean compressive strength / Min. compressive strength single brick ¹⁾		Use conditions				
5 / 4 N/mm ²	w/w	w/d	1,2		2,0	
	d/d		1,5		2,0	
8 / 6 N/mm ²	w/w	w/d	2,0		3,0	
	d/d		2,0		3,0	
10 / 8 N/mm ²	w/w	w/d	2,5		3,5	
	d/d		3,0		4,0	
12,5 / 10 N/mm ²	w/w	w/d	3,0		4,5	
	d/d		3,5		5,0	

¹⁾ The compressive strength of the single brick must not be less than 80% of the mean compressive strength.

²⁾ For temperature range 72/120°C: $N_{RK(72/120^\circ C)} = 0,83 \cdot N_{RK(50/80^\circ C)}$.

Factor for job site tests and displacements see annex C 123.

fischer injection system FIS V Plus for masonry

Performance

Light-weight concrete hollow block Hbl, Characteristic resistance under tension loading

Annex C 106

Appendix 135 / 153

Light-weight concrete hollow block Hbl, EN 771-3:2011+A1:2015

Table C107.1: Characteristic resistance to local brick failure or brick edge failure of a single anchor under shear loading (Pre-positioned anchorage)

Anchor rod	M6	M8	M6	M8	-	M8	M10	M8	M10	-	M12	M16	M12	M16
Internal threaded anchor FIS E	-		-		M6	M8	-		-		M10	M12	-	
					11x85						15x85			
Perforated sleeve FIS H K	12x50		12x85		16x85			16x130		20x85			20x130	

Shear resistance $V_{Rk} = V_{Rk,b} = V_{Rk,c,II} = V_{Rk,c,\perp}$ [kN] depending on the mean compressive strength f_b ; Installation and use condition w/w, w/d, d/d; (temperature range 50/80°C and 72/120°C)

Mean compressive strength / Min. compressive strength single brick ¹⁾	Use conditions											
5 / 4 N/mm ²	w/w w/d	0,75	1,20	0,75	1,20	0,75						1,20
	d/d											
8 / 6 N/mm ²	w/w w/d	1,20	2,00	1,20	2,00	1,20						2,00
	d/d											
10 / 8 N/mm ²	w/w w/d	1,50	2,50	1,50	2,50	1,50						2,50
	d/d											
12,5 / 10 N/mm ²	w/w w/d	2,00	3,00	2,00	3,00	2,00						3,00
	d/d											

¹⁾ The compressive strength of the single brick must not be less than 80% of the mean compressive strength.

Table C107.2: Characteristic resistance to local brick failure or brick edge failure of a single anchor under shear loading (Push through anchorage)

Anchor rod	M10	M12	M16
Perforated sleeve FIS H K	18x130/200		22x130/200

Shear resistance $V_{Rk} = V_{Rk,b} = V_{Rk,c,II} = V_{Rk,c,\perp}$ [kN] depending on the mean compressive strength f_b ; Installation and use condition w/w, w/d, d/d; (temperature range 50/80°C and 72/120°C)

Mean compressive strength / Min. compressive strength single brick ¹⁾	Use conditions											
5 / 4 N/mm ²	w/w w/d											1,2
	d/d											
8 / 6 N/mm ²	w/w w/d											2,0
	d/d											
10 / 8 N/mm ²	w/w w/d											2,5
	d/d											
12,5 / 10 N/mm ²	w/w w/d											3,0
	d/d											

¹⁾ The compressive strength of the single brick must not be less than 80% of the mean compressive strength.

Factor for job site tests and displacements see annex C 123.

fischer injection system FIS V Plus for masonry

Performance
Light-weight concrete hollow block Hbl, Characteristic resistance under shear loading

Annex C 107

Appendix 136 / 153

Light-weight concrete solid block Vbl, EN 771-3:2011+A1:2015

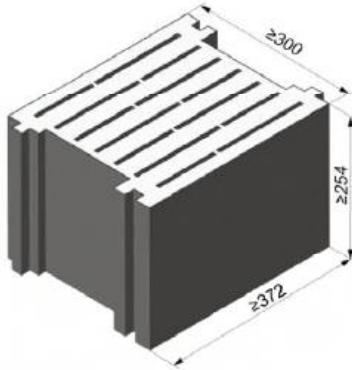

Producer	e.g. Sepa			
Nominal dimensions	[mm]	length L	width W	height H
		≥ 372	≥ 300	≥ 254
Mean gross dry density ρ	[kg/dm ³]	≥ 0,6		
Mean compressive strength / Min. compressive strength single brick ¹⁾	[N/mm ²]	2,5 / 2		
Standard or annex	EN 771-3:2011+A1:2015			

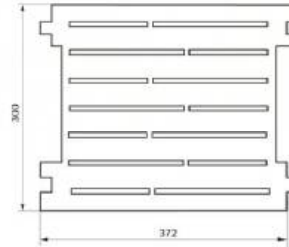

Dimension see also Annex B 20

Table C108.1: Installation parameters

Anchor rod	M8	M10	M10	M12	M12	M16	M16	M12	M16
Perforated sleeve FIS H K	16x130		18x130/200		20x130		22x130/200		20x200
Anchor rod with perforated sleeve FIS H K									
Max. installation torque	max T _{inst} [Nm]		4						
General installation parameters									
Edge distance	c _{min} = c _{cr}		130						
Spacing	s _{min} = s _{cr} [mm]		370						
	s _{min} ⊥ = s _{cr} ⊥		250						

Drilling method

Hammer drilling with hard metal hammer drill

¹⁾ The compressive strength of the single brick must not be less than 80% of the mean compressive strength.

Table C108.2: Group factors

Anchor rod	M8	M10	M10	M12	M12	M16	M16	M12	M16
Perforated sleeve FIS H K	16x130		18x130/200		20x130		22x130/200		20x200
Group factors	$\alpha_{g,N} (s_{min})$		[-]						
	$\alpha_{g,V} (s_{min})$								
	$\alpha_{g,N} (s_{min} \perp)$								
	$\alpha_{g,V} (s_{min} \perp)$								
2									

fischer injection system FIS V Plus for masonry

Performance
Light-weight concrete solid block Vbl, dimensions, installation parameters

Annex C 108

Appendix 137 / 153

Light-weight concrete solid block Vbl, EN 771-3:2011+A1:2015

Table C109.1: Characteristic resistance to pull-out failure or brick breakout failure of a single anchor under tension loading

Anchor rod	M8	M10	M10	M12	M12	M16	M16	M12	M16
Perforated sleeve FIS H K	16x130		18x130/200		20x130		22x130/200		20x200
Tension resistance $N_{Rk} = N_{Rk,p} = N_{Rk,b} = N_{Rk,p,c} = N_{Rk,b,c}$ [kN] depending on the mean compressive strength f_b ; Installation and use condition w/w, w/d, d/d; (temperature range 50/80°C) ²⁾									
Mean compressive strength / Min. compressive strength single brick ¹⁾	Use conditions								
2,5 / 2 N/mm ²	w/w	w/d	2,0			2,5			3,0
	d/d		2,0			3,0			4,0

¹⁾ The compressive strength of the single brick must not be less than 80% of the mean compressive strength.

²⁾ For temperature range 72/120°C: $N_{Rk(72/120°C)} = 0,83 \cdot N_{Rk(50/80°C)}$.

Table C109.2: Characteristic resistance to local brick failure or brick edge failure of a single anchor under shear loading

Anchor rod	M8	M10	M10	M12	M12	M16	M16	M12	M16
Perforated sleeve FIS H K	16x130		18x130/200		20x130		22x130/200		20x200
Shear resistance $V_{Rk} = V_{Rk,b} = V_{Rk,c,II} = V_{Rk,c,\perp}$ [kN] depending on the mean compressive strength f_b ; Installation and use condition w/w, w/d, d/d; (temperature range 50/80°C and 72/120°C)									
Mean compressive strength / Min. compressive strength single brick ¹⁾	Use conditions								
2,5 / 2 N/mm ²	w/w	w/d	4,5			6,5			
	d/d								

¹⁾ The compressive strength of the single brick must not be less than 80% of the mean compressive strength.

Factor for job site tests and displacements see annex C 123.

fischer injection system FIS V Plus for masonry

Performance
Light-weight concrete solid block Vbl,
Characteristic resistance under tension and shear loading

Annex C 109

Appendix 138 / 153

Light-weight concrete solid block Vbl, EN 771-3:2011+A1:2015

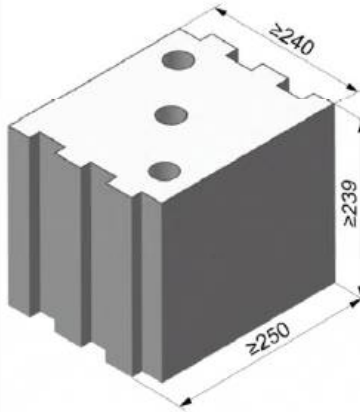

Producer		KLB		
Nominal dimensions	[mm]	length L	width W	height H
		≥ 250	≥ 240	≥ 239
Mean gross dry density ρ	[kg/dm ³]	≥ 1,6		
Mean compressive strength / Min. compressive strength single brick ¹⁾	[N/mm ²]	5 / 4 or 8 / 6 or 10 / 8		
Standard or annex		EN 771-3:2011+A1:2015		

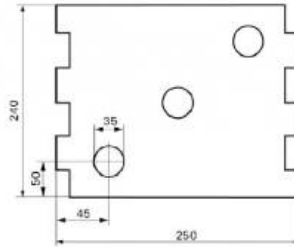

Dimension see also Annex B 20

Table C110.1: Installation parameters
(Pre-positioned anchorage with perforated sleeve FIS H K)

Anchor rod	M6	M8	M6	M8	-	M8	M10	M8	M10	-	M12	M16	M12	M16	M12	M16
Internal threaded anchor FIS E	-		-		M6	M8	-		-		M10	M12	-		-	
					11x85						15x85					
Perforated sleeve FIS H K	12x50		12x85		16x85			16x130			20x85		20x130		20x200	

Anchor rod and internal threaded anchor FIS E with perforated sleeve FIS H K

Max. installation torque $\max T_{inst}$ [Nm]	4
---	---

General installation parameters

Edge distance $c_{min} = c_{cr}$	130
Spacing $s_{min \parallel} = s_{cr \parallel}$ [mm]	250
	$s_{min \perp} = s_{cr \perp}$

Drilling method

Hammer drilling with hard metal hammer drill

¹⁾ The compressive strength of the single brick must not be less than 80% of the mean compressive strength.

Table C110.2: Group factors

Anchor rod	M6	M8	M6	M8	-	M8	M10	M8	M10	-	M12	M16	M12	M16	M12	M16
Internal threaded anchor FIS E	-		-		M6	M8	-		-		M10	M12	-		-	
					11x85						15x85					
Perforated sleeve FIS H K	12x50		12x85		16x85			16x130			20x85		20x130		20x200	

Group factors	$\alpha_{g,N} (s_{min \parallel})$	[-]	2,0
	$\alpha_{g,V} (s_{min \parallel})$		
	$\alpha_{g,N} (s_{min \perp})$		
	$\alpha_{g,V} (s_{min \perp})$		

fischer injection system FIS V Plus for masonry

Performance
Light-weight concrete solid block Vbl, dimensions, installation parameters

Annex C 110

Appendix 139 / 153

Light-weight concrete solid block Vbl, EN 771-3:2011+A1:2015

Table C111.1: Installation parameters
(Push through anchorage with perforated sleeve FIS H K)

Anchor rod	M10	M12	M16
Perforated sleeve FIS H K	18x130/200		22x130/200
Anchor rod with perforated sleeve FIS H K			
Max. installation torque $\max T_{inst}$ [Nm]	2,0		
General installation parameters			
Edge distance $c_{min} = c_{cr}$	130		
Spacing s_{min} [mm]	$s_{min \parallel} = s_{cr \parallel}$	250	
	$s_{min \perp} = s_{cr \perp}$	250	
Drilling method			
Hammer drilling with hard metal hammer drill			

Table C111.2: Group factors

Anchor rod	M10	M12	M16
Perforated sleeve FIS H K	18x130/200		22x130/200
Group factors	[-]	2,0	
$\alpha_{g,N} (s_{min \parallel})$			
$\alpha_{g,V} (s_{min \parallel})$			
$\alpha_{g,N} (s_{min \perp})$			
$\alpha_{g,V} (s_{min \perp})$			

fischer injection system FIS V Plus for masonry

Performance
Light-weight concrete solid block Vbl, dimensions, installation parameters

Annex C 111

Appendix 140 / 153

Light-weight concrete solid block Vbl, EN 771-3:2011+A1:2015

Table C112.1: Characteristic resistance to pull-out failure or brick breakout failure of a single anchor under tension loading (Pre-positioned anchorage)

Anchor rod	M6	M8	M6	M8	-	M8	M10	M8	M10	-	M12	M16	M12	M16	M12	M16
Internal threaded anchor FIS E	-		-		M6	M8	-		-		M10	M12	-		-	
					11x85						15x85					
Perforated sleeve FIS H K	12x50		12x85		16x85			16x130		20x85			20x130		20x200	

Tension resistance $N_{Rk} = N_{Rk,p} = N_{Rk,b} = N_{Rk,p,c} = N_{Rk,b,c}$ [kN] depending on the mean compressive strength f_b ; Installation and use condition w/w, w/d, d/d; (temperature range 50/80°C)²⁾

Mean compressive strength / Min. compressive strength single brick ¹⁾	Use conditions						
	w/w	w/d					
5 / 4 N/mm ²	w/w	w/d	1,2	2,0	2,5		3,0
		d/d	2,0	3,5	4,0		5,0
8 / 6 N/mm ²	w/w	w/d	1,5	3,0	4,0		5,0
		d/d	3,0	5,0	6,5		7,5
10 / 8 N/mm ²	w/w	w/d	2,0	4,0	5,0		6,5
		d/d	4,0	7,0	8,5		9,0

¹⁾ The compressive strength of the single brick must not be less than 80% of the mean compressive strength.

²⁾ For temperature range 72/120°C: $N_{Rk(72/120^\circ C)} = 0,83 \cdot N_{Rk(50/80^\circ C)}$.

Table C112.2: Characteristic resistance to pull-out failure or brick breakout failure of a single anchor under tension loading (Push through anchorage)

Anchor rod	M10	M12	M16
Perforated sleeve FIS H K	18x130/200		22x130/200

Tension resistance $N_{Rk} = N_{Rk,p} = N_{Rk,b} = N_{Rk,p,c} = N_{Rk,b,c}$ [kN] depending on the mean compressive strength f_b ; Installation and use condition w/w, w/d, d/d; (temperature range 50/80°C)²⁾

Mean compressive strength / Min. compressive strength single brick ¹⁾	Use conditions			
	w/w	w/d		
5 / 4 N/mm ²	w/w	w/d	2,5	
		d/d	4,0	
8 / 6 N/mm ²	w/w	w/d	4,0	
		d/d	6,5	
10 / 8 N/mm ²	w/w	w/d	5,0	
		d/d	8,5	

¹⁾ The compressive strength of the single brick must not be less than 80% of the mean compressive strength.

²⁾ For temperature range 72/120°C: $N_{Rk(72/120^\circ C)} = 0,83 \cdot N_{Rk(50/80^\circ C)}$.

Factor for job site tests and displacements see annex C 123.

fischer injection system FIS V Plus for masonry

Performance

Light-weight concrete solid block Vbl, Characteristic resistance under tension loading

Annex C 112

Appendix 141 / 153

Light-weight concrete solid block Vbl, EN 771-3:2011+A1:2015

Table C113.1: Characteristic resistance to local brick failure or brick edge failure of a single anchor under shear loading (Pre-positioned anchorage)

Anchor rod	M6	M8	M6	M8	-	M8	M10	M8	M10	-	M12	M16	M12	M16	M12	M16
Internal threaded anchor FIS E	-		-		M6	M8	-		-		M10	M12	-		-	
					11x85						15x85					
Perforated sleeve FIS H K	12x50		12x85		16x85			16x130		20x85			20x130		20x200	

Shear resistance $V_{Rk} = V_{Rk,b} = V_{Rk,c,II} = V_{Rk,c,\perp}$ [kN] depending on the mean compressive strength f_b ; Installation and use condition w/w, w/d, d/d; (temperature range 50/80°C and 72/120°C)

Mean compressive strength / Min. compressive strength single brick ¹⁾	Use conditions															
5 / 4 N/mm ²	w/w w/d	2,0	3,0	2,0	3,0	2,0	3,5					4,5				
	d/d															
8 / 6 N/mm ²	w/w w/d	3,0	4,5	3,0	4,5	3,0	5,5					6,5				
	d/d															
10 / 8 N/mm ²	w/w w/d	4,0	6,0	4,0	6,0	4,0	7,0					8,5				
	d/d															

¹⁾ The compressive strength of the single brick must not be less than 80% of the mean compressive strength.

Table C113.2: Characteristic resistance to local brick failure or brick edge failure of a single anchor under shear loading (Push through anchorage)

Anchor rod	M10				M12				M16			
Perforated sleeve FIS H K	18x130/200								22x130/200			

Shear resistance $V_{Rk} = V_{Rk,b} = V_{Rk,c,II} = V_{Rk,c,\perp}$ [kN] depending on the mean compressive strength f_b ; Installation and use condition w/w, w/d, d/d; (temperature range 50/80°C and 72/120°C)

Mean compressive strength / Min. compressive strength single brick ¹⁾	Use conditions												
5 / 4 N/mm ²	w/w w/d	3,5								4,5			
	d/d												
8 / 6 N/mm ²	w/w w/d	5,5								6,5			
	d/d												
10 / 8 N/mm ²	w/w w/d	7,0								8,5			
	d/d												

¹⁾ The compressive strength of the single brick must not be less than 80% of the mean compressive strength.

Factor for job site tests and displacements see annex C 123.

fischer injection system FIS V Plus for masonry

Performance
Light-weight concrete solid block Vbl, Characteristic resistance under shear loading

Annex C 113

Appendix 142 / 153

Light-weight concrete solid block Vbl, EN 771-3:2011+A1:2015

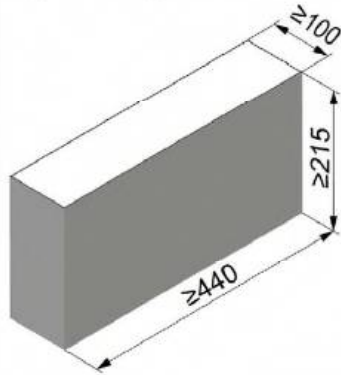

Producer		Roadstone wood		
Nominal dimensions	[mm]	length L	width W	height H
		≥ 440	≥ 100	≥ 215
Mean gross dry density ρ	[kg/dm ³]	≥ 2,0		
Mean compressive strength / Min. compressive strength single brick ¹⁾	[N/mm ²]	5 / 4 or 8 / 6 or 10 / 8 or 12,5 / 10		
Standard or annex		EN 771-3:2011+A1:2015		

Table C114.1: Installation parameters

Anchor rod		M6	M8	M10	M12	M16	
Anchor rod without perforated sleeve							
Effective anchorage depth h_{ef}	[mm]	50	70	50	70	50	70
Max. installation torque $\max T_{inst}$	[Nm]	4		10			
General installation parameters							
Edge distance $c_{min} = c_{cr}$		100					
Spacing	$s_{min II}$	75					
	$s_{cr II}$	3x h_{ef}					
	$s_{min \perp}$	75					
	$s_{cr \perp}$	3x h_{ef}					

Drilling method

Hammer drilling with hard metal hammer drill

¹⁾ The compressive strength of the single brick must not be less than 80% of the mean compressive strength.

Table C114.2: Group factors

Anchor rod		M6	M8	M10	M12	M16
Group factors	$\alpha_{g,N} (s_{min II})$	1,6				
	$\alpha_{g,V} (s_{min II})$	1,3				
	$\alpha_{g,N} (s_{min \perp})$	1,4				
	$\alpha_{g,V} (s_{min \perp})$	1,3				

fischer injection system FIS V Plus for masonry

Performance
Light-weight concrete solid block Vbl, dimensions, installation parameters

Annex C 114

Appendix 143 / 153

Light-weight concrete solid block Vbl, EN 771-3:2011+A1:2015

Table C115.1: Characteristic resistance to pull-out failure or brick breakout failure of a single anchor under tension loading

Anchor rod		M6	M8	M10	M12	M16
Tension resistance $N_{Rk} = N_{Rk,p} = N_{Rk,b} = N_{Rk,p,c} = N_{Rk,b,c}$ [kN] depending on the mean compressive strength f_b; Installation and use condition w/w, w/d, d/d; (temperature range 50/80°C) ²⁾						
Mean compressive strength / Min. compressive strength single brick ¹⁾	Use conditions	Effective anchorage depth h_{ef} [mm]				
		≥ 50				
5 / 4 N/mm ²	w/w w/d	1,2			1,2	
	d/d	2,0			2,0	
8 / 6 N/mm ²	w/w w/d	1,5			2,0	
	d/d	3,0			3,5	
10 / 8 N/mm ²	w/w w/d	2,0			2,5	
	d/d	4,0			4,5	
12,5 / 10 N/mm ²	w/w w/d	3,0			3,5	
	d/d	5,0			5,5	

¹⁾ The compressive strength of the single brick must not be less than 80% of the mean compressive strength.

²⁾ For temperature range 72/120°C: $N_{Rk(72/120°C)} = 0,83 \cdot N_{Rk(50/80°C)}$.

Table C115.2: Characteristic resistance to local brick failure or brick edge failure of a single anchor under shear loading

Anchor rod		M6	M8	M10	M12	M16
Shear resistance $V_{Rk} = V_{Rk,b} = V_{Rk,c,II} = V_{Rk,c,I}$ [kN] depending on the mean compressive strength f_b; Installation and use condition w/w, w/d, d/d; (temperature range 50/80°C and 72/120°C)						
Mean compressive strength / Min. compressive strength single brick ¹⁾	Use conditions	Effective anchorage depth h_{ef} [mm]				
		≥ 50				
5 / 4 N/mm ²	w/w w/d	1,2	1,5	1,5	1,5	1,5
	d/d					
8 / 6 N/mm ²	w/w w/d	2,0	2,0	2,5	2,5	2,5
	d/d					
10 / 8 N/mm ²	w/w w/d	2,5	2,5	3,0	3,0	3,5
	d/d					
12,5 / 10 N/mm ²	w/w w/d	3,0	3,5	4,0	4,0	4,5
	d/d					

¹⁾ The compressive strength of the single brick must not be less than 80% of the mean compressive strength.

Factor for job site tests and displacements see annex C 123.

fischer injection system FIS V Plus for masonry

Performance
Light-weight concrete solid block Vbl,
Characteristic resistance under tension and shear loading

Annex C 115

Appendix 144 / 153

Light-weight concrete solid block Vbl, EN 771-3:2011+A1:2015

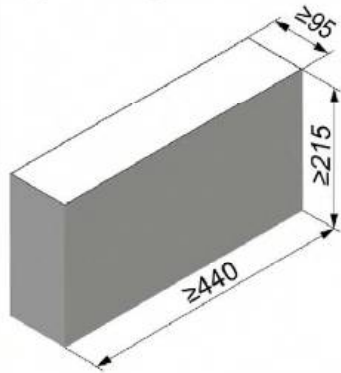

Producer	Tramac			
Nominal dimensions	[mm]	length L	width W	height H
		≥ 440	≥ 95	≥ 215
Mean gross dry density ρ	[kg/dm ³]	≥ 2,0		
Mean compressive strength / Min. compressive strength single brick ¹⁾	[N/mm ²]	7,5 / 6 or 10 / 8 or 12,5 / 10 or 15 / 12		
Standard or annex	EN 771-3:2011+A1:2015			

Table C116.1: Installation parameters

Anchor rod	M6		M8		M10		M12		M16		
Anchor rod without perforated sleeve											
Effective anchorage depth h_{ef}	[mm]	50	70	50	70	50	70	50	70	50	70
Max. installation torque $\max T_{inst}$	[Nm]	4		10							
General installation parameters											
Edge distance $c_{min} = c_{cr}$		60									
Spacing	$s_{min \parallel}$	75									
	$s_{cr \parallel}$	3x h_{ef}									
	$s_{min \perp}$	75									
	$s_{cr \perp}$	3x h_{ef}									

Drilling method

Hammer drilling with hard metal hammer drill

¹⁾ The compressive strength of the single brick must not be less than 80% of the mean compressive strength.

Table C116.2: Group factors

Anchor rod	M6		M8		M10		M12		M16		
Group factors	$\alpha_{g,N} (s_{min \parallel})$	[-]	1,9								
	$\alpha_{g,V} (s_{min \parallel})$		1,4								
	$\alpha_{g,N} (s_{min \perp})$		1,9								
	$\alpha_{g,V} (s_{min \perp})$		1,4								

fischer injection system FIS V Plus for masonry

Performance

Light-weight concrete solid block Vbl, dimensions, installation parameters

Annex C 116

Appendix 145 / 153

Light-weight concrete solid block Vbl, EN 771-3:2011+A1:2015

Table C117.1: Characteristic resistance to pull-out failure or brick breakout failure of a single anchor under tension loading

Anchor rod		M6	M8	M10	M12	M16					
Tension resistance $N_{Rk} = N_{Rk,p} = N_{Rk,b} = N_{Rk,p,c} = N_{Rk,b,c}$ [kN] depending on the mean compressive strength f_b ; Installation and use condition w/w, w/d, d/d; (temperature range 50/80°C) ²⁾											
Mean compressive strength / Min. compressive strength single brick ¹⁾	Use conditions	Effective anchorage depth h_{ef} [mm]									
		50	70	50	70	50	70	50	70	50	70
7,5 / 6 N/mm ²	w/w w/d	1,5	2,0	1,5	2,0	1,5	2,0	1,5	2,0	1,5	2,0
	d/d	2,5	3,5	2,5	3,5	2,5	3,5	2,5	3,5	2,5	3,5
10 / 8 N/mm ²	w/w w/d	2,0	2,5	2,0	2,5	2,0	3,0	2,0	3,0	2,0	3,0
	d/d	3,5	4,5	3,5	4,5	3,5	5,0	3,5	5,0	3,5	5,0
12,5 / 10 N/mm ²	w/w w/d	2,5	3,5	2,5	3,5	2,5	3,5	2,5	3,5	2,5	3,5
	d/d	4,5	6,0	4,5	6,0	4,5	6,0	4,5	6,0	4,5	6,0
15 / 12 N/mm ²	w/w w/d	3,0	4,0	3,0	4,0	3,0	4,5	3,0	4,5	3,0	4,5
	d/d	5,0	7,0	5,0	7,0	5,0	7,5	5,0	7,5	5,0	7,5

1) The compressive strength of the single brick must not be less than 80% of the mean compressive strength.

2) For temperature range 72/120°C: $N_{Rk(72/120°C)} = 0,83 \cdot N_{Rk(50/80°C)}$.

Table C117.2: Characteristic resistance to local brick failure or brick edge failure of a single anchor under shear loading

Anchor rod		M6	M8	M10	M12	M16
Shear resistance $V_{Rk} = V_{Rk,b} = V_{Rk,c,II} = V_{Rk,c,I}$ [kN] depending on the mean compressive strength f_b ; Installation and use condition w/w, w/d, d/d; (temperature range 50/80°C and 72/120°C)						
Mean compressive strength / Min. compressive strength single brick ¹⁾	Use conditions	Effective anchorage depth h_{ef} [mm]				
		≥ 50				
7,5 / 6 N/mm ²	w/w w/d	2,0	2,0	2,0	1,5	1,5
	d/d					
10 / 8 N/mm ²	w/w w/d	2,5	2,5	3,0	2,5	2,5
	d/d					
12,5 / 10 N/mm ²	w/w w/d	3,5	3,5	4,0	3,0	3,0
	d/d					
15 / 12 N/mm ²	w/w w/d	4,0	4,0	4,5	3,5	3,5
	d/d					

1) The compressive strength of the single brick must not be less than 80% of the mean compressive strength.

Factor for job site tests and displacements see annex C 123.

fischer injection system FIS V Plus for masonry

Performance
Light-weight concrete solid block Vbl,
Characteristic resistance under tension and shear loading

Annex C 117

Appendix 146 / 153

Autoclaved aerated concrete (cylindrical drill hole), EN 771-4:2011+A1:2015



Producer	e.g. Ytong			
Mean gross dry density ρ	[kg/dm ³]	0,35	0,5	0,65
Mean compressive strength / Min. compressive strength single brick ¹⁾	[N/mm ²]	2,5 / 2	5 / 4	8 / 6
Standard or annex	EN 771-4:2011+A1:2015			

Table C118.1: Installation parameters

Anchor rod	M6	M8	M10	M12	M16	-	-		
Internal threaded anchor FIS E	-	-	-	-	-	M6	M8	M10	M12
	11x85		15x85						

Anchor rod and internal threaded anchor FIS E without perforated sleeve

Effective anchorage depth h_{ef}	[mm]	100	200	100	200	100	200	100	200	100	200	100	200	85	
Max. installation torque $\max T_{inst}$	[Nm]	1	4	1	8	2	12	2	16	2	20	1	2		

General installation parameters

Edge distance $c_{min} = c_{cr}$		100
$s_{cr \parallel} = s_{min \parallel}$		250
$h_{ef}=200mm$ $s_{min \parallel}$ [mm]		80
$h_{ef}=200mm$ $s_{cr \parallel}$		3x h_{ef}
Spacing $s_{cr \perp} = s_{min \perp}$		250
$h_{ef}=200mm$ $s_{min \perp}$		80
$h_{ef}=200mm$ $s_{cr \perp}$		3x h_{ef}

Drilling method

Hammer drilling with hard metal hammer drill

¹⁾ The compressive strength of the single brick must not be less than 80% of the mean compressive strength.

fischer injection system FIS V Plus for masonry

Performance
Autoclaved aerated concrete (cylindrical drill hole), dimensions, installation parameters

Annex C 118

Appendix 147 / 153

Table C119.1: Group factors for autoclaved aerated concrete
(Compressive strength $f_b = 2 \text{ N/mm}^2$)

Anchor rod	M6	M8	M10	M12	M16	-	-		
Internal threaded anchor FIS E	-	-	-	-	-	M6	M8	M10	M12
						11x85		15x85	
Group factors	[-]	$h_{ef}=200 \alpha_{g,N} (S_{min II})$	1,6			-1)	-1)		
		$h_{ef}=200 \alpha_{g,V} (S_{min II})$	1,1			-1)	-1)		
		$\alpha_{g,N II}, \alpha_{g,V} (S_{min II})$	2						
		$h_{ef}=200 \alpha_{g,N} (S_{min \perp})$	1,6			-1)	-1)		
		$h_{ef}=200 \alpha_{g,V} (S_{min \perp})$	0,8			-1)	-1)		
		$\alpha_{g,N \perp}, \alpha_{g,V} (S_{min \perp})$	2						

1) No performance assessed.

Table C119.2: Group factors for autoclaved aerated concrete
(Compressive strength $f_b = 4 \text{ N/mm}^2$)

Anchor rod	M6	M8	M10	M12	M16	-	-		
Internal threaded anchor FIS E	-	-	-	-	-	M6	M8	M10	M12
						11x85		15x85	
Group factors	[-]	$h_{ef}=200 \alpha_{g,N} (S_{min II})$	0,7			-1)	-1)		
		$h_{ef}=200 \alpha_{g,V} (S_{min II})$	2,0			-1)	-1)		
		$\alpha_{g,N II}, \alpha_{g,V} (S_{min II})$	2						
		$h_{ef}=200 \alpha_{g,N} (S_{min \perp})$	0,7			-1)	-1)		
		$h_{ef}=200 \alpha_{g,V} (S_{min \perp})$	1,2			-1)	-1)		
		$\alpha_{g,N \perp}, \alpha_{g,V} (S_{min \perp})$	2						

1) No performance assessed.

Table C119.3: Group factors for autoclaved aerated concrete
(Compressive strength $f_b = 6 \text{ N/mm}^2$)

Anchor rod	M6	M8	M10	M12	M16	-	-		
Internal threaded anchor FIS E	-	-	-	-	-	M6	M8	M10	M12
						11x85		15x85	
Group factors	[-]	$h_{ef}=200 \alpha_{g,N} (S_{min II})$	0,7			-1)	-1)		
		$h_{ef}=200 \alpha_{g,V} (S_{min II})$	2,0			-1)	-1)		
		$\alpha_{g,N II}, \alpha_{g,V} (S_{min II})$	2						
		$h_{ef}=200 \alpha_{g,N} (S_{min \perp})$	0,7			-1)	-1)		
		$h_{ef}=200 \alpha_{g,V} (S_{min \perp})$	1,2			-1)	-1)		
		$\alpha_{g,N \perp}, \alpha_{g,V} (S_{min \perp})$	2						

1) No performance assessed.

fischer injection system FIS V Plus for masonry

Performance
Autoclaved aerated concrete (cylindrical drill hole), Group factors

Annex C 119

Appendix 148 / 153

Autoclaved aerated concrete (cylindrical drill hole), EN 771-4:2011+A1:2015

Table C120.1: Characteristic resistance to pull-out failure or brick breakout failure of a single anchor under tension loading

Anchor rod	M6		M8		M10		M12		M16		-		-	
Internal threaded anchor FIS E	-		-		-		-		-		M6	M8	M10	M12
											11x85		15x85	
Tension resistance $N_{Rk} = N_{Rk,p} = N_{Rk,b} = N_{Rk,p,c} = N_{Rk,b,c}$ [kN] depending on the mean compressive strength $f_{c,m}$; Installation and use condition w/w, w/d, d/d; (temperature range 50/80°C) ³⁾														
Mean compressive strength / Min. compressive strength single brick ²⁾	Use conditions	Effective anchorage depth h_{ef} [mm]												
		100	200	100	200	100	200	100	200	100	200	100	200	85
2,5 / 2 N/mm ²	w/w	w/d	1,2	1,2	1,5	2,0	1,5	3,0	1,5	3,0	2,0	3,0	1,5	1,5
	d/d		1,5	3,0	1,5	3,0	1,5	3,5	2,0	4,0	2,0	4,0	1,5	1,5
5 / 4 N/mm ²	w/w	w/d	1,2	- ¹⁾	2,0	1,5	2,5	3,5	2,5	3,5	2,0	3,5	2,0	1,5
	d/d		1,5	- ¹⁾	2,0	3,0	3,0	5,0	2,5	5,0	2,0	5,0	2,0	1,5
8 / 6 N/mm ²	w/w	w/d	1,5	- ¹⁾	3,0	2,5	4,5	5,0	4,5	7,0	3,0	8,5	3,5	2,5
	d/d		1,5	- ¹⁾	3,5	4,0	5,0	7,0	5,0	9,0	3,0	11,5	3,5	2,5

1) No performance assessed.

2) The compressive strength of the single brick must not be less than 80% of the mean compressive strength.

3) For temperature range 72/120°C: $N_{Rk(72/120^\circ C)} = 0,83 \cdot N_{Rk(50/80^\circ C)}$.

Table C120.2: Characteristic resistance to local brick failure or brick edge failure of a single anchor under shear loading

Anchor rod	M6		M8		M10		M12		M16		-		-	
Internal threaded anchor FIS E	-		-		-		-		-		M6	M8	M10	M12
											11x85		15x85	
Shear resistance $V_{Rk} = V_{Rk,b} = V_{Rk,c,II} = V_{Rk,c,\perp}$ [kN] depending on the mean compressive strength $f_{c,m}$; Installation and use condition w/w, w/d, d/d; (temperature range 50/80°C and 72/120°C)														
Mean compressive strength / Min. compressive strength single brick ²⁾	Use conditions	Effective anchorage depth h_{ef} [mm]												
		100	200	100	200	100	200	100	200	100	200	100	200	85
2,5 / 2 N/mm ²	w/w	w/d	1,2	1,2	1,2	1,2	1,2	1,2	1,5	1,2	1,2	1,2	1,2	1,5
	d/d													
5 / 4 N/mm ²	w/w	w/d	2,0	- ¹⁾	2,5	2,0	2,0	2,0	2,5	2,0	2,0	2,0	2,0	2,5
	d/d													
8 / 6 N/mm ²	w/w	w/d	2,5	- ¹⁾	3,0	2,5	3,0	3,0	3,5	4,0	4,5	4,5	2,5	3,5
	d/d													

1) No performance assessed.

2) The compressive strength of the single brick must not be less than 80% of the mean compressive strength.

Factor for job site tests and displacements see annex C 123.

fischer injection system FIS V Plus for masonry

Performance

Autoclaved aerated concrete (cylindrical drill hole),
Characteristic resistance under tension and shear loading

Annex C 120

Appendix 149 / 153

**Autoclaved aerated concrete (conical drill hole with special drill bit PBB),
EN 771-4:2011+A1:2015**

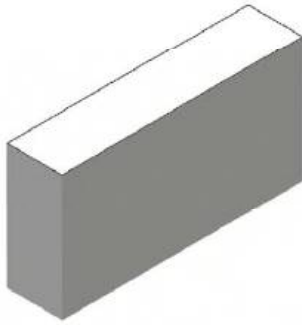

Producer	e.g. Ytong			
Mean gross dry density ρ	[kg/dm ³]	0,35	0,5	0,65
Mean compressive strength / Min. compressive strength single brick ¹⁾	[N/mm ²]	2,5 / 2	5 / 4	8 / 6
Standard or annex	EN 771-4:2011+A1:2015			

Table C121.1: Installation parameters

Anchor rod	M8		M10		M12		-	
Internal threaded anchor FIS E	-	-	-	-	-	-	M6	M8
Anchor rod and internal threaded anchor FIS E without perforated sleeve								
Effective anchorage depth h_{ef}	[mm]	75	95	75	95	75	95	85
Max. installation torque $\max T_{inst}$	[Nm]	2						
General installation parameters								
Edge distance $c_{min} = c_{cr}$		120	150	120	150	120	150	150
Spacing	$s_{cr \parallel} = s_{min \parallel}$	240	300	240	300	240	300	300
	$s_{cr \perp} = s_{min \perp}$	240	250	240	250	240	250	250

Drilling method

Hammer drilling with hard metal hammer drill

¹⁾ The compressive strength of the single brick must not be less than 80% of the mean compressive strength.

Table C121.2: Group factors

Anchor rod	M8		M10		M12		-			
Internal threaded anchor FIS E	-	-	-	-	-	-	M6	M8		
Group factors	$\alpha_{g,N} (s_{min \parallel})$	[-]	2						11x85	
	$\alpha_{g,V} (s_{min \parallel})$									
	$\alpha_{g,N} (s_{min \perp})$									
	$\alpha_{g,V} (s_{min \perp})$									

fischer injection system FIS V Plus for masonry

Performance

Autoclaved aerated concrete (conical drill hole with special drill bit PBB),
dimensions, installation parameters

Annex C 121

Appendix 150 / 153

**Autoclaved aerated concrete (conical drill hole with special drill bit PBB),
EN 771-4:2011+A1:2015**

Table C122.1: Characteristic resistance to pull-out failure or brick breakout failure of a single anchor under tension loading

Anchor rod		M8		M10		M12		-	
Internal threaded anchor FIS E		-	-	-	-	-	-	M6	M8
11x85									
Tension resistance $N_{Rk} = N_{Rk,p} = N_{Rk,b} = N_{Rk,p,c} = N_{Rk,b,c}$ [kN] depending on the mean compressive strength $f_{c,m}$; Installation and use condition w/w, w/d, d/d; (temperature range 50/80°C)²⁾									
Mean compressive strength / Min. compressive strength single brick ¹⁾	Use conditions	Effective anchorage depth h_{ef} [mm]							
		75	95	75	95	75	95	85	
2,5 / 2 N/mm²	w/w w/d	2,0	2,5	2,0	2,5	2,0	2,5	2,0	
	d/d	2,0	2,5	2,0	2,5	2,0	2,5	2,0	
5 / 4 N/mm²	w/w w/d	3,0	3,5	3,0	3,5	3,0	3,5	3,0	
	d/d	3,0	3,5	3,0	3,5	3,0	3,5	3,0	
8 / 6 N/mm²	w/w w/d	3,5	4,0	3,5	4,0	3,5	4,0	3,5	
	d/d	4,0	4,5	4,0	4,5	4,0	4,5	4,0	

¹⁾ The compressive strength of the single brick must not be less than 80% of the mean compressive strength.

²⁾ For temperature range 72/120°C: $N_{Rk(72/120°C)} = 0,83 \cdot N_{Rk(50/80°C)}$.

Table C122.2: Characteristic resistance under shear loading

Anchor rod		M8		M10		M12		-	
Internal threaded anchor FIS E		-	-	-	-	-	-	M6	M8
11x85									
Shear resistance $V_{Rk} = V_{Rk,b} = V_{Rk,c,II} = V_{Rk,c,\perp}$ [kN] depending on the mean compressive strength $f_{c,m}$; Installation and use condition w/w, w/d, d/d; (temperature range 50/80°C and 72/120°C)									
Mean compressive strength / Min. compressive strength single brick ¹⁾	Use conditions	Effective anchorage depth h_{ef} [mm]							
		75	95	75	95	75	95	85	
2,5 / 2 N/mm²	w/w w/d	2,5							
	d/d								
5 / 4 N/mm²	w/w w/d	4,5							
	d/d								
8 / 6 N/mm²	w/w w/d	6,0							
	d/d								

¹⁾ The compressive strength of the single brick must not be less than 80% of the mean compressive strength.

Factor for job site tests and displacements see annex C 123.

fischer injection system FIS V Plus for masonry

Performance

Autoclaved aerated concrete (conical drill hole with special drill bit PBB),
Characteristic resistance under tension and shear loading

Annex C 122

Appendix 151 / 153

β-factors for job site tests; displacements

Table C123.1: β-factors for job site tests

use conditions		w/w and w/d		d/d	
temperature range [°C]		50/80	72/120	50/80	72/120
Material	Size				
solid units	M6	0,55	0,46	0,96	0,80
	M8	0,57	0,51		
	M10	0,59	0,52		
	M12 FIS E 11x85	0,60	0,54		
	M16 FIS E 15x85	0,62	0,52		
	FIS H 16x85 K	0,55	0,46		
hollow units	all sizes	0,86	0,72	0,96	0,80
Autoclaved aerated concrete cylindrical drill hole	all sizes	0,73	0,73	0,81	0,81
Autoclaved aerated concrete conical drill hole	all sizes	0,66	0,59	0,73	0,66

Table C123.2: Displacements

Material	N [kN]	δN ₀ [mm]	δN _∞ [mm]	V [kN]	δV ₀ [mm]	δV _∞ [mm]
solid units and autoclaved aerated concrete h _{ef} =100mm	$\frac{N_{Rk}}{1,4 * \gamma_{Mm}}$	0,03	0,06	$\frac{V_{Rk}}{1,4 * \gamma_{Mm}}$	0,82	0,88
hollow units	$\frac{N_{Rk}}{1,4 * \gamma_{Mm}}$	0,48	0,06	$\frac{V_{Rk}}{1,4 * \gamma_{Mm}}$	1,71	2,56
solid brick Mz NF annex C 4 - C 7	$\frac{N_{Rk}}{1,4 * \gamma_{Mm}}$	0,74	1,48	$\frac{V_{Rk}}{1,4 * \gamma_{Mm}}$	1,23	1,85
solid brick KS NF annex C 14 / C 15	$\frac{N_{Rk}}{1,4 * \gamma_{Mm}}$	0,20	0,40	$\frac{V_{Rk}}{1,4 * \gamma_{Mm}}$	0,91	1,37
AAC h _{ef} =200 mm annex C 118 - C 120	$\frac{N_{Rk}}{1,4 * \gamma_{Mm}}$	1,03	2,06	$\frac{V_{Rk}}{1,4 * \gamma_{Mm}}$	1,25	1,88
brick Annex C 101 / C 102	$\frac{N_{Rk}}{1,4 * \gamma_{Mm}}$	0,03	0,06	$\frac{V_{Rk}}{1,4 * \gamma_{Mm}}$	6,44	9,66

For anchorage in autoclaved aerated concrete, the partial factor γ_{MAAC} shall be used instead of γ_{Mm} .

fischer injection system FIS V Plus for masonry

Performance
β-factors for job site tests; displacements

Annex C 123

Appendix 152 / 153

Fire resistance under tension and shear loading

Table C124.1: Fire resistance under tension and shear loading

Brick	Solid brick Mz,NF, acc. to Annex C 4			Solid calcium silicate brick KS, NF,acc. to Annex C 14			Perforated calcium silicate brick KSL, acc to Annex C 24			Vertical perforated brick HLz, acc to Annex C 30			Vertical perforated brick HLz, acc to Annex C 28		
	Mean compressive strength / Min. compressive strength single brick ³⁾	≥ 15 / ≥ 12			≥ 15 / ≥ 12			≥ 10 / ≥ 8			≥ 7,5 / ≥ 6			≥ 5 / ≥ 4	
Size	M8	M10	M12	M8	M10	M12	M8	M10	M12	M8	M10	M12	M8	M10	M12
Perforated Sleeve	-			-			16x130		20x130	16x85		20x85	16x130		20x130
Perforated Sleeve for bridging of unbearing layer	-			-			-		20x200	16x130		20x130	-		20x200
h_{ef}	[mm] ≥ 80			≥ 50			≥ 130		≥ 130	≥ 85		≥ 85	≥ 130		≥ 130

Characteristic resistance to failure under tension loading

$N_{Rk,s,fi}$ $N_{Rk,p,fi}$ $N_{Rk,b,fi}$ ²⁾	R30	[kN]	0,82	0,32	1,07	1,09	1,10	0,28	0,30	0,35	0,31	
	R60		0,73	0,31	0,66	0,61	0,56	0,19	0,22	0,22	0,22	0,22
	R90		0,64	0,29	0,25	0,13	- ¹⁾	0,10	0,10	0,10	0,10	0,13
	R120		0,59	0,28	- ¹⁾	- ¹⁾	- ¹⁾	- ¹⁾	- ¹⁾	- ¹⁾	- ¹⁾	- ¹⁾

Characteristic resistance to failure under shear loading ²⁾

without lever arm

$V_{Rk,s,fi}$	R30	[kN]	0,82	0,32	1,07	1,09	1,10	0,28	0,30	0,35	0,31
	R60		0,73	0,31	0,66	0,61	0,56	0,19	0,22	0,22	0,22
	R90		0,64	0,29	0,25	0,13	- ¹⁾	0,10	0,10	0,10	0,13
	R120		0,59	0,28	- ¹⁾	- ¹⁾	- ¹⁾	- ¹⁾	- ¹⁾	- ¹⁾	- ¹⁾

with lever arm

$M^0_{Rk,s,fi}$	R30	[Nm]	0,83	1,05	1,27	0,33	0,42	0,50	1,09	1,40	1,71	0,29	0,39	0,54	0,32	0,40	0,48
	R60		0,74	0,93	1,13	0,31	0,39	0,47	0,67	0,78	0,86	0,19	0,28	0,34	0,22	0,28	0,34
	R90		0,65	0,82	0,99	0,29	0,37	0,44	0,26	0,17	- ¹⁾	0,10	0,12	0,15	0,13	0,16	0,20
	R120		0,60	0,76	0,92	0,28	0,35	0,43	- ¹⁾	- ¹⁾	- ¹⁾	- ¹⁾	- ¹⁾	- ¹⁾	- ¹⁾	- ¹⁾	- ¹⁾

General installation Parameters

Edge distance and spacing	$c_{cr,fi}$	[mm]	100	60	80	80	100
	$s_{cr,fi}$		320	200	520	340	520

1) No performance assessed.

2) $V_{Rk,b,fi} = N_{Rk,b,fi}$.

3) The compressive strength of the single brick must not be less than 80% of the mean compressive strength.

In absence of national regulations, the recommended partial factor $\gamma_{M,fi} = 1,0$.

fischer injection system FIS V Plus for masonry

Performance

Fire resistance to failure under tension and shear loading; Fire resistance to pull-out failure or brick breakout failure of a single anchor under tension loading

Annex C 124

Appendix 153 / 153