

The Drawing and its contents are to be kept secret from third parties, particularly competitors. The drawing and documents which go with it are not to be duplicated either in local or extract, or used in other documentation without express approval (§15 and 38 UrHG - §1 and 18 UWG). A reservation of rights in accordance with §12 PatG is declared for the event that a patent is granted.

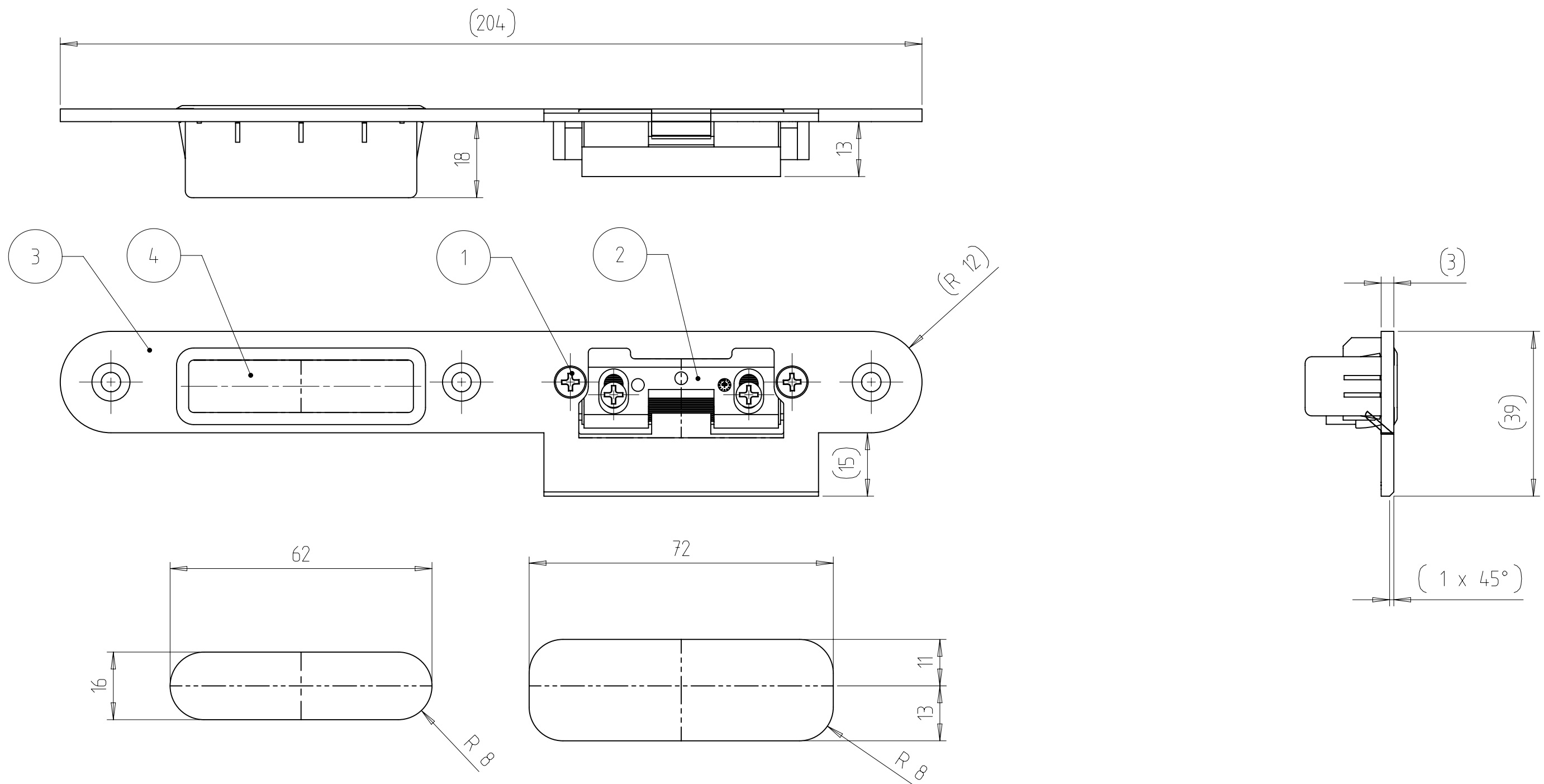

Frästiefe = angegebene Tiefe + min. 1 mm

Fräser \varnothing 16 mm
Anlaufring \varnothing 27 mm

Wie gezeichnet DIN links
spiegelbildlich DIN rechts

Tolerierund nach ISO 8015

Pos. 4 in Pos. 3 geklipst
Pos. 2 und Pos. 3 mit Pos. 1 verschraubt

4	Hinterfueterung	1	9.806.00080	000		
3	Lappen-Schliessblech	1	9.870.00045	000		
2	AT-Stueck kplt.	1	7.803.00038	000		
1	Senkschraube DIN 965-M4x6	2	9.999.03370	000		
Pos	Benennung	Stck	PDM-Nr.	Teil	Bemerk	
Qty.	Type of Modification	Ansicht aktualisiert		ANT	Drawn	
1				Y3999E	SenguelN	
Volume /mm ³	Weight/g	Material-No.	Item-No.	Approved	Date	
22173	141,460		8050-752ERH	ThodeP	12.06.2013	
		Tolerance	Part-Discription			
Scale	Additional Notice		Lappen-Schliessblech			
1:1			Document No.	Doc. Part No.	Revision	
Drawn	Axmann	KFV	7.870.00008	000	03	
Date	15.04.2010				20	
Appr.	CzerneckiD		Replaced for :	Test procedure		Size
Date	16.04.2010		Replaced by :			A3